

**ASME B16.34-2017**  
(Revision of ASME B16.34-2013)

# **Valves — Flanged, Threaded, and Welding End**

---

**AN AMERICAN NATIONAL STANDARD**



**The American Society of  
Mechanical Engineers**

**ASME B16.34-2017**  
(Revision of ASME B16.34-2013)

# **Valves — Flanged, Threaded, and Welding End**

---

**AN AMERICAN NATIONAL STANDARD**



**The American Society of  
Mechanical Engineers**

Two Park Avenue • New York, NY • 10016 USA

Date of Issuance: August 23, 2017

The next edition of this Standard is scheduled for publication in 2020.

ASME issues written replies to inquiries concerning interpretations of technical aspects of this Standard. Periodically certain actions of the ASME B16 Committee may be published as Cases. Cases and interpretations are published on the ASME Web site under the Committee Pages at <http://cstools.asme.org/> as they are issued.

Errata to codes and standards may be posted on the ASME Web site under the Committee Pages to provide corrections to incorrectly published items, or to correct typographical or grammatical errors in codes and standards. Such errata shall be used on the date posted.

The Committee Pages can be found at <http://cstools.asme.org/>. There is an option available to automatically receive an e-mail notification when errata are posted to a particular code or standard. This option can be found on the appropriate Committee Page after selecting "Errata" in the "Publication Information" section.

ASME is the registered trademark of The American Society of Mechanical Engineers.

This code or standard was developed under procedures accredited as meeting the criteria for American National Standards. The Standards Committee that approved the code or standard was balanced to assure that individuals from competent and concerned interests have had an opportunity to participate. The proposed code or standard was made available for public review and comment that provides an opportunity for additional public input from industry, academia, regulatory agencies, and the public-at-large.

ASME does not "approve," "rate," or "endorse" any item, construction, proprietary device, or activity.

ASME does not take any position with respect to the validity of any patent rights asserted in connection with any items mentioned in this document, and does not undertake to insure anyone utilizing a standard against liability for infringement of any applicable letters patent, nor assume any such liability. Users of a code or standard are expressly advised that determination of the validity of any such patent rights, and the risk of infringement of such rights, is entirely their own responsibility.

Participation by federal agency representative(s) or person(s) affiliated with industry is not to be interpreted as government or industry endorsement of this code or standard.

ASME accepts responsibility for only those interpretations of this document issued in accordance with the established ASME procedures and policies, which precludes the issuance of interpretations by individuals.

No part of this document may be reproduced in any form,  
in an electronic retrieval system or otherwise,  
without the prior written permission of the publisher.

The American Society of Mechanical Engineers  
Two Park Avenue, New York, NY 10016-5990

Copyright © 2017 by  
THE AMERICAN SOCIETY OF MECHANICAL ENGINEERS  
All rights reserved  
Printed in U.S.A.

# CONTENTS

Foreword . . . . .	vii
Committee Roster . . . . .	ix
Correspondence With the B16 Committee . . . . .	x
Introduction . . . . .	xiii
Summary of Changes . . . . .	xiv
List of Changes in Record Number Order . . . . .	xvi
<b>1</b> <b>Scope</b> . . . . .	<b>1</b>
<b>2</b> <b>Pressure–temperature Ratings</b> . . . . .	<b>2</b>
<b>3</b> <b>Nominal Pipe Size</b> . . . . .	<b>4</b>
<b>4</b> <b>Marking</b> . . . . .	<b>4</b>
<b>5</b> <b>Materials</b> . . . . .	<b>5</b>
<b>6</b> <b>Dimensions</b> . . . . .	<b>6</b>
<b>7</b> <b>Pressure Testing</b> . . . . .	<b>11</b>
<b>8</b> <b>Requirements for Special Class Valves</b> . . . . .	<b>12</b>
<b>Mandatory Appendices</b>	
I      Radiography Examination: Procedure and Acceptance Standards . . . . .	121
II     Magnetic Particle Examination: Procedure and Acceptance Standards . . . . .	123
III    Liquid Penetrant Examination: Procedure and Acceptance Standards . . . . .	124
IV    Ultrasonic Examination: Procedure and Acceptance Standards . . . . .	125
V     Requirements for Limited Class Valves . . . . .	126
VI    Basis Equations for Minimum Wall Thickness . . . . .	129
VII   Pressure–temperature Ratings: U.S. Customary Units . . . . .	131
VIII   References . . . . .	210
<b>Nonmandatory Appendices</b>	
A      Relationship Between Nominal Pipe Size and Inside Diameter . . . . .	214
B      Method Used for Establishing Pressure–temperature Ratings . . . . .	216
C      Quality System Program . . . . .	224
<b>Figures</b>	
1      Method of Designating Location of Auxiliary Connections When Specified . . . . .	14
2      Butterfly Valve Body . . . . .	15
3      Thread Length for Auxiliary Connections . . . . .	16
4      Bosses for Auxiliary Connections . . . . .	16
5      Socket Welding for Auxiliary Connections . . . . .	17
6      Butt Welding for Auxiliary Connections . . . . .	17
7      Gate Body (Pressure Seal Bonnet) . . . . .	18

8	Y Pattern Globe Body (Pressure Seal Bonnet) . . . . .	18
9	Angle Body (Pressure Seal Bonnet): Bonnet Same As Y Pattern Globe . . . . .	19
10	Elbow Down (Pressure Seal Bonnet) . . . . .	19
11	Gate Body (Flanged Bonnet) . . . . .	20
12	Globe Body (Flanged Bonnet) . . . . .	20
13	Butterfly Body . . . . .	21
14	Plug Body . . . . .	21
15	Conduit Gate Body (Pressure Seal Bonnet) . . . . .	22
16	Dished Cover . . . . .	22
17	Flat Cover . . . . .	22
V-1	Limited Class Stress Area Limits . . . . .	127

**Tables**

1	Material Specification List: Applicable ASTM Specifications . . . . .	23
2-1.1	Ratings for Group 1.1 Materials . . . . .	28
2-1.2	Ratings for Group 1.2 Materials . . . . .	30
2-1.3	Ratings for Group 1.3 Materials . . . . .	32
2-1.4	Ratings for Group 1.4 Materials . . . . .	34
2-1.5	Ratings for Group 1.5 Materials . . . . .	36
2-1.6	Ratings for Group 1.6 Materials . . . . .	37
2-1.7	Ratings for Group 1.7 Materials . . . . .	38
2-1.8	Ratings for Group 1.8 Materials . . . . .	40
2-1.9	Ratings for Group 1.9 Materials . . . . .	42
2-1.10	Ratings for Group 1.10 Materials . . . . .	44
2-1.11	Ratings for Group 1.11 Materials . . . . .	46
2-1.12	Ratings for Group 1.12 Materials . . . . .	48
2-1.13	Ratings for Group 1.13 Materials . . . . .	50
2-1.14	Ratings for Group 1.14 Materials . . . . .	52
2-1.15	Ratings for Group 1.15 Materials . . . . .	54
2-1.16	Ratings for Group 1.16 Materials . . . . .	56
2-1.17	Ratings for Group 1.17 Materials . . . . .	58
2-1.18	Ratings for Group 1.18 Materials . . . . .	60
2-2.1	Ratings for Group 2.1 Materials . . . . .	62
2-2.2	Ratings for Group 2.2 Materials . . . . .	64
2-2.3	Ratings for Group 2.3 Materials . . . . .	66
2-2.4	Ratings for Group 2.4 Materials . . . . .	67
2-2.5	Ratings for Group 2.5 Materials . . . . .	69
2-2.6	Ratings for Group 2.6 Materials . . . . .	71
2-2.7	Ratings for Group 2.7 Materials . . . . .	73
2-2.8	Ratings for Group 2.8 Materials . . . . .	75
2-2.9	Ratings for Group 2.9 Materials . . . . .	76
2-2.10	Ratings for Group 2.10 Materials . . . . .	78
2-2.11	Ratings for Group 2.11 Materials . . . . .	80
2-2.12	Ratings for Group 2.12 Materials . . . . .	82
2-3.1	Ratings for Group 3.1 Materials . . . . .	84

2-3.2	Ratings for Group 3.2 Materials . . . . .	85
2-3.3	Ratings for Group 3.3 Materials . . . . .	86
2-3.4	Ratings for Group 3.4 Materials . . . . .	88
2-3.5	Ratings for Group 3.5 Materials . . . . .	89
2-3.6	Ratings for Group 3.6 Materials . . . . .	91
2-3.7	Ratings for Group 3.7 Materials . . . . .	93
2-3.8	Ratings for Group 3.8 Materials . . . . .	94
2-3.9	Ratings for Group 3.9 Materials . . . . .	96
2-3.10	Ratings for Group 3.10 Materials . . . . .	98
2-3.11	Ratings for Group 3.11 Materials . . . . .	99
2-3.12	Ratings for Group 3.12 Materials . . . . .	100
2-3.13	Ratings for Group 3.13 Materials . . . . .	101
2-3.14	Ratings for Group 3.14 Materials . . . . .	102
2-3.15	Ratings for Group 3.15 Materials . . . . .	103
2-3.16	Ratings for Group 3.16 Materials . . . . .	105
2-3.17	Ratings for Group 3.17 Materials . . . . .	107
2-3.18	Ratings for Group 3.18 Materials . . . . .	108
2-3.19	Ratings for Group 3.19 Materials . . . . .	110
3A	Valve Body Minimum Wall Thickness, $t_m$ , mm . . . . .	112
3B	Valve Body Minimum Wall Thickness, $t_m$ , in. . . . .	116
4	Minimum Wall Thickness for Socket Welding and Threaded Ends . . . . .	120
I-1	Acceptance Criteria for Thickness Per para. I-2(a) . . . . .	122
I-2	Acceptance Criteria for Thickness Per para. I-2(b) . . . . .	122
I-3	Acceptance Criteria for Thickness Per para. I-2(c) . . . . .	122
V-1	Material Coefficient, $y$ . . . . .	127
VI-1	Basis Equations for Minimum Wall Thickness, mm . . . . .	129
VI-2	Basis Equations for Minimum Wall Thickness, in. . . . .	130
VII-2-1.1	Ratings for Group 1.1 Materials . . . . .	132
VII-2-1.2	Ratings for Group 1.2 Materials . . . . .	133
VII-2-1.3	Ratings for Group 1.3 Materials . . . . .	134
VII-2-1.4	Ratings for Group 1.4 Materials . . . . .	136
VII-2-1.5	Ratings for Group 1.5 Materials . . . . .	137
VII-2-1.6	Ratings for Group 1.6 Materials . . . . .	138
VII-2-1.7	Ratings for Group 1.7 Materials . . . . .	139
VII-2-1.8	Ratings for Group 1.8 Materials . . . . .	140
VII-2-1.9	Ratings for Group 1.9 Materials . . . . .	142
VII-2-1.10	Ratings for Group 1.10 Materials . . . . .	144
VII-2-1.11	Ratings for Group 1.11 Materials . . . . .	146
VII-2-1.12	Ratings for Group 1.12 Materials . . . . .	148
VII-2-1.13	Ratings for Group 1.13 Materials . . . . .	150
VII-2-1.14	Ratings for Group 1.14 Materials . . . . .	152
VII-2-1.15	Ratings for Group 1.15 Materials . . . . .	154
VII-2-1.16	Ratings for Group 1.16 Materials . . . . .	156
VII-2-1.17	Ratings for Group 1.17 Materials . . . . .	158
VII-2-1.18	Ratings for Group 1.18 Materials . . . . .	160

VII-2-2.1	Ratings for Group 2.1 Materials . . . . .	162
VII-2-2.2	Ratings for Group 2.2 Materials . . . . .	164
VII-2-2.3	Ratings for Group 2.3 Materials . . . . .	166
VII-2-2.4	Ratings for Group 2.4 Materials . . . . .	167
VII-2-2.5	Ratings for Group 2.5 Materials . . . . .	169
VII-2-2.6	Ratings for Group 2.6 Materials . . . . .	171
VII-2-2.7	Ratings for Group 2.7 Materials . . . . .	173
VII-2-2.8	Ratings for Group 2.8 Materials . . . . .	175
VII-2-2.9	Ratings for Group 2.9 Materials . . . . .	176
VII-2-2.10	Ratings for Group 2.10 Materials . . . . .	178
VII-2-2.11	Ratings for Group 2.11 Materials . . . . .	180
VII-2-2.12	Ratings for Group 2.12 Materials . . . . .	182
VII-2-3.1	Ratings for Group 3.1 Materials . . . . .	184
VII-2-3.2	Ratings for Group 3.2 Materials . . . . .	185
VII-2-3.3	Ratings for Group 3.3 Materials . . . . .	186
VII-2-3.4	Ratings for Group 3.4 Materials . . . . .	188
VII-2-3.5	Ratings for Group 3.5 Materials . . . . .	189
VII-2-3.6	Ratings for Group 3.6 Materials . . . . .	191
VII-2-3.7	Ratings for Group 3.7 Materials . . . . .	193
VII-2-3.8	Ratings for Group 3.8 Materials . . . . .	194
VII-2-3.9	Ratings for Group 3.9 Materials . . . . .	196
VII-2-3.10	Ratings for Group 3.10 Materials . . . . .	197
VII-2-3.11	Ratings for Group 3.11 Materials . . . . .	198
VII-2-3.12	Ratings for Group 3.12 Materials . . . . .	199
VII-2-3.13	Ratings for Group 3.13 Materials . . . . .	200
VII-2-3.14	Ratings for Group 3.14 Materials . . . . .	201
VII-2-3.15	Ratings for Group 3.15 Materials . . . . .	202
VII-2-3.16	Ratings for Group 3.16 Materials . . . . .	204
VII-2-3.17	Ratings for Group 3.17 Materials . . . . .	205
VII-2-3.18	Ratings for Group 3.18 Materials . . . . .	206
VII-2-3.19	Ratings for Group 3.19 Materials . . . . .	208
A-1	Inside Diameter, $d$ . . . . .	215
B-1	Pressure–temperature Matrix . . . . .	219
B-2	Class-Diameter Matrix . . . . .	219
B-3M	Ceiling Pressure, bar . . . . .	220
B-3	Ceiling Pressure, psi . . . . .	222

# FOREWORD

In December 1969, American National Standards Committee B16 changed its name from Standardization of Pipe Flanges and Fittings to Standardization of Valves, Fittings, and Gaskets, reflecting American National Standards Institute (ANSI) approval of a broadened scope for the B16 Committee. At the same meeting, the committee approved a plan for the organization of a subcommittee to develop a new standard for steel valves with other than flanged ends. Subsequently, B16 Subcommittee 15 was appointed and held its first meeting in December 1970.

Historically, in the development of standards and pressure–temperature ratings for steel valves, the various rating classes for flanges provided an obviously logical basis for valve ratings. Steel valves with flanges of standard dimensions, many also offered in buttwelding-end versions, were given the same pressure–temperature ratings as the flanges. In 1949, a new edition of the Standard, then designated B16e-1949, was published, in which a table covering wall thickness requirements for weld end valves had been added. In 1964, the Manufacturer's Standardization Society of the Valve and Fittings Industry developed and published Standard Practice SP-66, covering pressure–temperature ratings of steel buttwelding-end valves. MSS SP-66 introduced a new method for establishing ratings by making ratings a function of the mechanical strength properties of the body material at all temperatures. Following the publication of MSS SP-66, B16 activated Subcommittee 4 for the purpose of studying the general subject of pressure–temperature ratings and developing rational criteria for such ratings.

In the B16 charge to Subcommittee 15, it was established that the new Standard would replace MSS SP-66 and also remove the reference to buttwelding-end valves from B16.5. Flanged-end valves would continue to be covered in B16.5 but on a fully specified basis, rather than as an add-on.

As the work of the subcommittee got underway, concurrent action was initiated in Subcommittee 3 for revision of B16.5. Subsequent operations of Subcommittees 3 and 15 were closely coordinated to provide assurance that the new Standard and the revised B16.5 would be compatible.

A key and basic issue of mutual concern in this coordination was the matter of pressure–temperature ratings. It was necessary to incorporate the SP-66-type ratings in the new Standard, but at the same time also to provide ratings equivalent to those in B16.5 covering the buttwelding equivalents of flanged-end valves. Subcommittee 4 had made definitive recommendations for revisions in the flange ratings and it was obviously desirable to rationalize the two types of ratings as they would appear side-by-side in the new Standard.

The results of these efforts appear herein in the form of pressure–temperature ratings tables. The method of computing the ratings is detailed in [Nonmandatory Appendix B](#). The ratings differ from the pre-1968 B16.5 ratings because they are now calculated as a function of the mechanical properties of the pressure boundary materials, in contrast to the empirical basis used previously. A change in the SP 66-type rating (herein designated Special Class) discontinues the application of a plasticity factor at elevated temperatures which, in the opinion of the committee, could not be justified in dimension-sensitive valves.

Other innovations include the coverage of forged or fabricated body valves and an increase in detailed coverage by pressure–temperature ratings from 17 materials in B16.5 to 24 material groups in the new Standard and in the revised B16.5. Dimensional requirements were refined and augmented to give the designer more latitude and the user more assurance of adequacy. A number of the innovations have had trial use and at least some degree of acceptance, as they have been taken from the section on valve requirements developed and published by the ASME Boiler and Pressure Vessel Code to cover valves used in nuclear power plants. A section on valve testing eliminates uncertainties on such points as seat test requirements and stem seal testing.

Approval for the 1973 edition of the Standard by ANSI was granted in October 1973.

In December 1973, a reorganization of the subcommittee structure for B16 was approved. Subcommittee 15 was redesignated as Subcommittee N and was assigned responsibility for all steel valves. Work began to include coverage for flanged-end valves in ANSI B16.34. The 1977 edition contained flanged-end valve requirements formerly in ANSI B16.5. The rating procedures of B16.5 were adopted and made applicable to Standard Class buttwelding-end valves. The method of deriving ratings was revised. Major changes were made in the method for determining ratings for austenitic stainless steel valves and ratings for Class 150 valves for all materials. The pressure–temperature tables and materials groups were rearranged and revised using data from the reference Sections of the ASME Boiler and Pressure Vessel Code through the Summer 1975 Addenda. A number of clarifying and editorial revisions were also made in order to improve the text. It was also resolved that frequent minor changes in pressure–temperature ratings because of revisions to the reference material



strength property tables should be avoided and that, as a general guide, such changes should not be considered unless resulting ratings would be changed by an amount in excess of 10%.

Approval for the 1977 edition of the Standard by ANSI was granted on June 16, 1977.

In 1979, work began on the 1981 edition. Materials coverage was expanded. Nickel alloys and other alloys were added. Bolting rules were revised to accommodate special alloy bolting for the new materials. Revisions were included to clarify requirements for rotary motion valves, e.g., ball valves and butterfly valves. Wafer-type valves were specifically identified. Other clarifying and editorial revisions were made in order to improve the text.

Following approvals by the Standards Committee and Secretariat, approval for the 1981 edition was granted by ANSI on August 14, 1981.

During 1985, revisions were proposed that added requirements for socket welding-end and threaded-end valves. The inclusion of requirements for these valves increased the scope of the Standard. Also, the listings for nickel alloy and other alloy valves materials were expanded. Rules for threaded body joints were added, and wafer-type valve body rules improved.

Following approvals by the Standards Committee and ASME, approval for the 1988 edition was granted by ANSI on February 24, 1988.

During 1993 and carrying over into 1994, revisions offered included multiple material marking and an improved interpolation procedure. New materials were added and the pressure–temperature rating tables were recalculated in accordance with [Nonmandatory Appendix B](#) using the latest data available from the reference ASME Boiler and Pressure Vessel Code sources. An appendix was added covering nonmandatory requirements for a quality system program.

Following the approvals of the Standards Committee and ASME, approval for the new edition was granted by ANSI on October 3, 1996.

Work started in 1999 to revise the Standard to include metric units as the primary reference units while maintaining U.S. Customary units in either parenthetical or separate forms. The goal is to delete the U.S. Customary units in a future revision. All pressure–temperature ratings have been recalculated using data from the latest edition of the ASME Boiler and Pressure Vessel Code, Section II, Part D. As a result, some materials have been shifted to other material groups and some changes were made to some valve ratings within material groups. Because of diminished interest for flanged end valves conforming to ASME Class 400, they are not specifically listed in this revision. Flanges for Class 400 will continue to be listed in B16 flange standards. Provisions were made to allow Class 400 valves to be furnished as intermediate rated valves. Numerous requirement clarifications and editorial revisions were also made.

Work started in 2007 to revise the Standard. Metric units remained the primary reference units with U.S. Customary units in either parenthetical or separate forms shown as in the earlier edition. Pressure–temperature ratings, in some cases, were revised, and new materials were added, all in keeping with the material properties provided in the latest edition of the ASME Boiler and Pressure Vessel Code, Section II, Part D. A number of requirement clarifications and editorial revisions were also made.

Following the approvals of the Standards Committee and ASME, approval for the 2009 edition was granted by ANSI on June 18, 2009.

Work started in 2009 to correct material listings with the material groups. Additionally, ASME B16.47 was added as a reference, and flanged-end valves coverage was expanded to NPS 50. A number of requirement clarifications and editorial revisions were also made.

Following the approvals of the Standards Committee and ASME, approval for the 2013 edition was granted by ANSI on February 19, 2013.

For 2017, valves up to NPS 60 are covered; a reference has been added for materials manufactured to other editions; and changes have been made to allowable materials. Pressure–temperature tables were also updated for consistency with the 2017 editions of ASME B16.5 and ASME B16.47.

This revision was approved by the American National Standards Institute on March 9, 2017.

# ASME B16 COMMITTEE

## Standardization of Valves, Flanges, Fittings, and Gaskets

(The following is the roster of the Committee at the time of approval of this Standard.)

### STANDARDS COMMITTEE OFFICERS

**R. M. Bojarczuk**, *Chair*  
**C. E. Davila**, *Vice Chair*  
**C. Ramcharran**, *Secretary*

### STANDARDS COMMITTEE PERSONNEL

**A. Appleton**, Alloy Stainless Products Co., Inc.  
**J. E. Barker**, Dezurik Water Controls  
**R. W. Barnes**, ANRIC Enterprises, Inc.  
**P. Milankov**, *Alternate*, ANRIC Enterprises, Inc.  
**K. Barron**, Ward Manufacturing  
**D. C. Bayreuther**, Metso Automation, Flow Control Division  
**W. B. Bedesem**, Consultant  
**R. M. Bojarczuk**, ExxonMobile Research and Engineering Co.  
**A. M. Cheta**, Qatar Shell GTL  
**M. A. Clark**, NIBCO, Inc.  
**G. A. Cuccio**, Capitol Manufacturing Co.  
**J. D'Avanzo**, Fluoroseal Valves  
**C. E. Davila**, Crane Energy  
**D. R. Frikken**, Becht Engineering Co., Inc.  
**R. B. Hai**, RBH Associates  
**G. A. Jolly**, Samshin Ltd.

**M. Katcher**, Haynes International  
**T. A. McMahon**, Emerson Process Management  
**M. L. Nayyar**, NICE  
**W. H. Patrick**, The Dow Chemical Co.  
**C. Ramcharran**, The American Society of Mechanical Engineers  
**D. Raho**, CCM 2000  
**R. A. Schmidt**, Canadoil  
**J. Tucker**, Flowserve  
**F. R. Volgstadt**, Volgstadt & Associates, Inc.  
**F. Feng**, *Delegate*, China Productivity Center for Machinery  
**P. V. Craig**, *Contributing Member*, Jomar Group  
**B. G. Fabian**, *Contributing Member*, Pennsylvania Machine Works  
**A. G. Kireta, Jr.**, *Contributing Member*, Copper Development Association, Inc.  
**D. F. Reid**, *Contributing Member*, VSP Technologies

### SUBCOMMITTEE N — STEEL VALVES AND FACE-TO-FACE AND END-TO-END DIMENSIONS OF VALVES

**J. P. Tucker**, *Chair*, Flowserve Corp.  
**G. A. Jolly**, *Vice Chair*, Samshin Ltd.  
**R. Lucas**, *Secretary*, The American Society of Mechanical Engineers  
**R. W. Barnes**, ANRIC Enterprises, Inc.  
**D. C. Bayreuther**, Metso Automation, Flow Control Division  
**W. B. Bedesem**, Consultant  
**R. A. Benjamin**, Newport News Shipbuilding  
**R. M. Bojarczuk**, ExxonMobil Research & Engineering Co.  
**A. M. Cheta**, Qatar Shell GTL  
**J. D'Avanzo**, Fluoroseal Valves  
**C. E. Davila**, Crane Energy  
**S. DuChes**, Bechtel Corp.  
**R. T. Faircloth**, Cameron  
**D. R. Frikken**, Becht Engineering Co., Inc.  
**E. Gulgun**, International Standard Valve, Inc.

**R. B. Hai**, RBH Associates  
**P. W. Heald**, Bonney Forge  
**J. R. Holstrom**, Val-Matic Valve & Manufacturing Corp.  
**M. Katcher**, Haynes International  
**T. N. MacDonald**, Sargent & Lundy  
**T. A. McMahon**, Emerson Process Management  
**R. C. Merrick**, Fluor Enterprises  
**M. L. Nayyar**, NICE  
**W. H. Patrick**, The Dow Chemical Co.  
**D. W. Raho**, CCM 2000  
**K. E. Reid II**, Parker Hannafin Corp.  
**C. Sumner**, Conval, Inc.  
**D. E. Tezzo**, Pentair Valves & Controls  
**M. M. Zaidi**, Jacobs Engineering

# CORRESPONDENCE WITH THE B16 COMMITTEE

**General.** ASME Standards are developed and maintained with the intent to represent the consensus of concerned interests. As such, users of this Standard may interact with the Committee by requesting interpretations, proposing revisions or a case, and attending Committee meetings. Correspondence should be addressed to:

Secretary, B16 Standards Committee  
The American Society of Mechanical Engineers  
Two Park Avenue  
New York, NY 10016-5990  
<http://go.asme.org/Inquiry>

**Proposing Revisions.** Revisions are made periodically to the Standard to incorporate changes that appear necessary or desirable, as demonstrated by the experience gained from the application of the Standard. Approved revisions will be published periodically.

The Committee welcomes proposals for revisions to this Standard. Such proposals should be as specific as possible, citing the paragraph number(s), the proposed wording, and a detailed description of the reasons for the proposal, including any pertinent documentation.

**Proposing a Case.** Cases may be issued to provide alternative rules when justified, to permit early implementation of an approved revision when the need is urgent, or to provide rules not covered by existing provisions. Cases are effective immediately upon ASME approval and shall be posted on the ASME Committee Web page.

Requests for Cases shall provide a Statement of Need and Background Information. The request should identify the Standard and the paragraph, figure, or table number(s), and be written as a Question and Reply in the same format as existing Cases. Requests for Cases should also indicate the applicable edition(s) of the Standard to which the proposed Case applies.

**Interpretations.** Upon request, the B16 Standards Committee will render an interpretation of any requirement of the Standard. Interpretations can only be rendered in response to a written request sent to the Secretary of the B16 Standards Committee.

Requests for interpretation should preferably be submitted through the online Interpretation Submittal Form. The form is accessible at <http://go.asme.org/InterpretationRequest>. Upon submittal of the form, the Inquirer will receive an automatic e-mail confirming receipt.

If the Inquirer is unable to use the online form, he/she may e-mail the request to the Secretary of the B16 Standards Committee at [SecretaryB16@asme.org](mailto:SecretaryB16@asme.org), or mail it to the above address. The request for an interpretation should be clear and unambiguous. It is further recommended that the Inquirer submit his/her request in the following format:

Subject:	Cite the applicable paragraph number(s) and the topic of the inquiry in one or two words.
Edition:	Cite the applicable edition of the Standard for which the interpretation is being requested.
Question:	Phrase the question as a request for an interpretation of a specific requirement suitable for general understanding and use, not as a request for an approval of a proprietary design or situation. Please provide a condensed and precise question, composed in such a way that a "yes" or "no" reply is acceptable.
Proposed Reply(ies):	Provide a proposed reply(ies) in the form of "Yes" or "No," with explanation as needed. If entering replies to more than one question, please number the questions and replies.
Background Information:	Provide the Committee with any background information that will assist the Committee in understanding the inquiry. The Inquirer may also include any plans or drawings that are necessary to explain the question; however, they should not contain proprietary names or information.

Requests that are not in the format described above may be rewritten in the appropriate format by the Committee prior to being answered, which may inadvertently change the intent of the original request.

ASME procedures provide for reconsideration of any interpretation when or if additional information that might affect an interpretation is available. Further, persons aggrieved by an interpretation may appeal to the cognizant ASME Committee or Subcommittee. ASME does not “approve,” “certify,” “rate,” or “endorse” any item, construction, proprietary device, or activity.

**Attending Committee Meetings.** The B16 Standards Committee regularly holds meetings and/or telephone conferences that are open to the public. Persons wishing to attend any meeting and/or telephone conference should contact the Secretary of the B16 Standards Committee.

INTENTIONALLY LEFT BLANK

# INTRODUCTION

An American National Standard is intended as a basis for common practice by the manufacturer, the user, and the general public. The existence of an American National Standard does not in itself preclude the manufacture, sale, or use of products not conforming to the standard. Mandatory conformance is established, for example, by reference to the standard in a code, specification, sales contract, or public law.

It should be noted, specifically regarding this Standard, that certain requirements reflecting the general application of valves in a wide variety of services may not be considered to be appropriate for some valves whose application is known and which may incorporate certain features found by successful experience to be satisfactory. A specific case in point is that involving valves developed and used in gas and petroleum product pipelines. Conformance of such valves to the existing API 6D may by itself be sufficient to satisfy requirements of federal rules and regulations established by the Department of Transportation, Office of Pipeline Safety Operations. Another specific case is that involving valves used in instrument systems under an applicable piping code. Conformance of such valves to the requirements of an existing piping code may by itself be sufficient to satisfy jurisdictional rules and regulations.

This edition of ASME B16.34 states values in both Metric and U.S. Customary units of measurement. These systems of units are to be regarded separately. The values stated in each system are not exact equivalents; therefore each system shall be used independently of the other. Combining values from the two systems constitutes nonconformance with this Standard.

# ASME B16.34-2017

## SUMMARY OF CHANGES

Following approval by the ASME B16 Committee and ASME, and after public review, ASME B16.34-2017 was approved by the American National Standards Institute on March 9, 2017.

ASME B16.34-2017 includes the following changes identified by a margin note, **(17)**.

<i>Page</i>	<i>Location</i>	<i>Change (Record Number)</i>
2	1.6	Added new para. 1.6; former para. 1.6 redesignated as para. 1.7 (14-1125)
2	2.1.1	Subparagraph (a) revised (11-2234)
3	2.1.6	Subparagraph (c)(1) revised and (c)(3) added (14-1125)
6	5.2.1	Revised (16-715)
6	6.1.1	Revised (16-701)
6	6.1.2	Subparagraph (c) revised (14-1124)
23	Table 1	(1) In Material Group No. 2.2, tenth row added, and former eleventh row deleted (13-1486) (2) Material Group No. 2.8 revised (14-1384)
75	Table 2-2.8	(1) A995 Gr. 6A revised to A995 Gr. CD3MN (14-1384) (2) A995 Gr. 1B revised to A995 Gr. CD4MCuN (14-1384) (3) A351 Gr. CE8MN revised to A995 Gr. CE8MN (14-1384)
112	Table 3A	(1) Under Class 900, entry for 710 mm revised (12-2084) (2) Rows for 1320 mm through 1500 mm added (11-2234)
116	Table 3B	Rows for 51.00 in. through 60.00 in. added (11-2234)
129	Table VI-1	In second column, third, sixth, and ninth entries revised (11-2234)
130	Table VI-2	In second column, third, sixth, and ninth entries revised (11-2234)
132	Table VII-2-1.1	Under A — Standard Class, eighth entry under Class 1500 revised (16-716)
137	Table VII-2-1.5	Under A — Standard Class, third entry under Class 900 and second entry under Class 1500 revised (16-716, 15-2360)
144	Table VII-2-1.10	Under A — Standard Class, thirteenth entry under Class 600 revised (15-2360)
164	Table VII-2-2.2	A182 Gr. F317H, A240 Gr. 317H, and A312 Gr. TP317H deleted (13-1486)

167	Table VII-2-2.4	Under A — Standard Class, for 1,050°F, entry under Class 300 revised <i>(15-2360)</i>
171	Table VII-2-2.6	Under B — Special Class, for 1,350°F, entry under Class 1500 revised <i>(15-2360)</i>
175	Table VII-2-2.8	(1) A995 Gr. 6A revised to A995 Gr. CD3MN <i>(14-1384)</i> (2) A995 Gr. 1B revised to A995 Gr. CD4MCuN <i>(14-1384)</i> (3) A351 Gr. CE8MN revised to A995 Gr. CE8MN <i>(14-1384)</i>
210	Mandatory Appendix VIII	(1) First paragraph revised <i>(10-532)</i> (2) ASTM A351 and ASTM A995 revised <i>(14-1384)</i> (3) MSS SP-134 added <i>(14-1125)</i>
215	Table A-1	Entries for NPS 52 through NPS 60 added <i>(11-2234)</i>



# LIST OF CHANGES IN RECORD NUMBER ORDER

<u>Record Number</u>	<u>Change</u>
10-532	Revised first paragraph in <a href="#">Mandatory Appendix VIII</a> so that other editions of ASTM specifications may be used with ASME B16.34.
11-2234	Revised <a href="#">para. 2.1.1(a)</a> and <a href="#">Tables 3A, 3B, VI-1, VI-2, and A-1</a> to cover valves up to NPS 60.
12-2084	Revised <a href="#">Table 3A</a> minimum wall thickness for Class 900 valve with 710 mm bore.
13-1486	Revised <a href="#">Tables 1</a> and <a href="#">VII-2-2.2</a> to remove Material 317H.
14-1124	Revised <a href="#">para. 6.1.2</a> .
14-1125	Added new <a href="#">para. 1.6</a> and revised <a href="#">para. 2.1.6(c)</a> by adding subparagraph (c). Added MSS SP-134-2012 to references in <a href="#">Mandatory Appendix VIII</a> .
14-1384	Revised <a href="#">Tables 1, 2-2.8, and VII-2-2.8</a> to correct ASTM material that does not exist. Updated ASTM A351 and ASTM A995 in <a href="#">Mandatory Appendix VIII</a> .
15-2360	Revised <a href="#">Tables VII-2-1.5, VII-2-1.10, VII-2-2.4, and VII-2-2.6</a> to align with ASME B16.5 and ASME B16.47.
16-701	Revised <a href="#">para. 6.1.1</a> to reference <a href="#">Nonmandatory Appendix B, B-4</a> , which addresses interpolation of intermediate minimum wall thickness.
16-715	Revised <a href="#">para. 5.2.1</a> to reference Section II, Part D, Nonmandatory Appendix A.
16-716	Revised <a href="#">Tables VII-2-1.1 and VII-2-1.5</a> to be consistent with ASME B16.5.

# VALVES — FLANGED, THREADED, AND WELDING END

## 1 SCOPE

### 1.1 General

This Standard applies to new construction and covers pressure–temperature ratings, dimensions, tolerances, materials, nondestructive examination requirements, testing, and marking for cast, forged, and fabricated flanged, threaded, and welding end and wafer or flangeless valves of steel, nickel-base alloys, and other alloys shown in [Table 1](#). Wafer or flangeless valves, bolted or through-bolt types, that are installed between flanges or against a flange are treated as flanged-end valves. Alternative rules for NPS 2½ and smaller valves are given in [Mandatory Appendix V](#).

### 1.2 Applicability

**1.2.1 Standards and Specifications.** Standards and specifications adopted by reference in this Standard and the names and addresses of the sponsoring organizations are shown in [Mandatory Appendix VIII](#). It is not considered practical to refer to a specific edition of each of the standards and specifications in the individual clause references. Instead, the specific edition references are included in [Mandatory Appendix VIII](#). A product made in conformance with a prior edition of reference standards and in all other respects conforming to this Standard shall be considered to be in conformance even though the edition reference may have been changed in a subsequent revision of this Standard.

**1.2.2 Time of Purchase, Manufacture, or Installation.** The pressure–temperature ratings included in this Standard are applicable, upon publication, to all valves covered within its scope that meet its requirements. For unused valves, valves that have been maintained in inventory, the manufacturer may certify conformance to this edition provided that it can be demonstrated that all requirements of this edition have been met. However, where such components were installed under the pressure–temperature ratings of an earlier edition of ASME B16.34, those ratings shall apply except as may be governed by an applicable Code or regulation.

**1.2.3 User Accountability.** This Standard cites duties and responsibilities that are to be assumed by the valve user in the areas of, for example, application, installation, system hydrostatic testing, operation, and material selection.

**1.2.4 Quality Systems.** Requirements relating to a valve manufacturer's Quality System Program are described in [Nonmandatory Appendix C](#).

**1.2.5 Relevant Units.** This Standard states values in both SI (Metric) and U.S. Customary units. These systems of units are to be regarded separately as standard. Within the text, the U.S. Customary units are shown in parentheses or in separate tables that appear in [Mandatory Appendix VII](#). The values stated in each system are not exact equivalents; therefore, it is required that each system of units be used independently of the other. Combining values from the two systems constitutes nonconformance with the Standard.

### 1.3 Selection of Valve Types and Material Service Conditions

Criteria for selection of valve types and materials suitable for particular fluid service are not within the scope of this Standard.

### 1.4 Convention

For determining conformance with this Standard, the convention for fixing significant digits where limits (maximum and minimum values) are specified shall be as defined in ASTM E29. This requires that an observed or calculated value be rounded off to the nearest unit in the last right-hand digit used for expressing the limit. Decimal values and tolerances do not imply a particular method of measurement.

### 1.5 Denotation

**1.5.1 Pressure Rating Designation.** Class followed by a dimensionless number is the designation for pressure–temperature ratings. Standardized designations are as follows:

Class	150	300	600	900	1500	2500	4500
-------	-----	-----	-----	-----	------	------	------

Class 400, an infrequently used flanged-end valve designation, is regarded as an intermediate class designation.

**1.5.2 Size.** NPS followed by a dimensionless number is the designation for nominal valve size. NPS is related to the reference *nominal diameter*, DN, used in international standards. The relationship is, typically, as follows:

NPS	DN
1/4	8
3/8	10
1/2	15
3/4	20
1	25
1 1/4	32
1 1/2	40
2	50
2 1/2	65
3	80
4	100

For NPS  $\geq 4$ , the related DN = 25  $\times$  NPS number.

## (17) 1.6 Cryogenic Service

Valves in cryogenic service shall meet the additional requirements specified in MSS SP-134.

## 1.7 References

Codes, standards, and specifications, containing provisions to the extent referenced herein, constitute requirements of this Standard. These reference documents are listed in [Mandatory Appendix VIII](#).

## 2 PRESSURE-TEMPERATURE RATINGS

### 2.1 General

Pressure-temperature ratings are designated by class numbers. Each class number is further identified as Standard, Special, or Limited Class.

- (17) **2.1.1 Rating Designations.** Pressure-temperature ratings are tabulated for Standard and Special Class Pressure Rating Designation numbers 150, 300, 600, 900, 1500, 2500, and 4500 in [Table 2-1.1](#) through [Table 2-3.19](#) in metric units and in [Mandatory Appendix VII](#) in U.S. Customary units. Ratings for Limited Class are determined by the method in [Mandatory Appendix V](#).<sup>1</sup>

(a) Flanged-end valves shall be rated only as Standard Class. Flanged-end valves larger than NPS 60 are beyond the scope of this Standard.

(b) Class 4500 applies only to welding-end valves.

(c) A class designation greater than Class 2500 or a rating temperature greater than 538°C (1,000°F) applied to threaded-end valves is beyond the scope of this Standard.

<sup>1</sup> Throughout this Standard the metric unit used for pressure is *bar* where 1 bar is equivalent to 0.1 MPa. Use of the term bar for pressure is an aid in distinguishing between values for pressure and stress where stress values are given in MPa units. This also recognizes the common usage of the term bar for pressure in International Standards for piping components such as valves and fittings.

(d) Threaded and socket welding-end valves larger than NPS 2 1/2 are beyond the scope of this Standard.

(e) Except as provided in [para. 2.5](#), the tabulated ratings are the maximum allowable working pressures, expressed as gage pressure, at the temperatures shown.

(f) Ratings intermediate to tabulated values are determined by linear interpolation between temperatures within a class number or between class numbers, except that for flanged-end valves interpolation between tabulated classes is not permitted. A further exception is that Class 400 valves having ASME B16.5 or ASME B16.47 flanged ends shall use the intermediate rating method of [para. 2.1.5](#).

(g) In all cases, valves shall be constructed so that the body, bonnet or cover, body bolting, and bonnet or cover bolting meet the 38°C (100°F) pressure rating requirements for the designated pressure class or pressure-temperature rating. However, pressure-temperature ratings for the valve may be otherwise limited by construction details or material design considerations, in which case the requirements of [paras. 4.3.3](#) and [7.2.6](#) shall be met.

**2.1.2 Standard Class Valves.** Valves conforming to the requirements of this Standard, except for those meeting the additional requirements of [section 8](#) for Special Class valves or of [Mandatory Appendix V](#) for Limited Class valves, shall be designated Standard Class valves. Ratings shall not exceed the values that are listed in [Table 2-1.1](#) through [Table 2-3.19](#) with an identifying label "A — Standard Class."

**2.1.3 Special Class Valves.** Threaded- or welding-end valves that conform to all the requirements of [para. 2.1.2](#), and in addition have successfully passed the examinations required by [section 8](#), may be designated Special Class valves. Pressure-temperature ratings shall not exceed the values that are listed in [Table 2-1.1](#) through [Table 2-3.19](#) with an identifying label "B — Special Class." Special Class ratings shall not be used for flanged-end valves.

**2.1.4 Limited Class Valves.** Welding- or threaded-end valves NPS 2 1/2 and smaller that conform to the requirements of [Mandatory Appendix V](#) may be designated Limited Class valves. Pressure-temperature ratings shall not exceed the values calculated in accordance with [Mandatory Appendix V](#). Limited Class ratings shall not be used for flanged-end valves.

**2.1.5 Intermediate Rated Valves.** A Standard Class or Special Class welding- or threaded-end valve or a Standard Class 400 flanged-end valve may be assigned an intermediate pressure-temperature rating or Class in accordance with [para. 6.1.4](#), provided all other applicable requirements of this Standard are met. Correspondingly, an intermediate pressure rating or

Class for Limited Class valves having welding ends or threaded ends may be assigned pressure–temperature ratings as determined by the method described in [Mandatory Appendix V](#) in conjunction with the interpolation procedure described in [para. 6.1.4](#).

- (17) **2.1.6 Valves Fabricated by Welding.** A valve made wholly or partly from segments of castings, forgings, bars, plates, or tubular product welded together will merit the applicable pressure–temperature rating only if
- (a) it conforms to all applicable requirements of this Standard
  - (b) weld fabrication and heat treatment of welds are in accordance with the ASME Boiler and Pressure Vessel Code, Section VIII, Division 1<sup>2</sup>
  - (c) nondestructive examination of welds is in accordance with the ASME Boiler and Pressure Vessel Code, Section VIII, Division 1, as required to warrant a joint efficiency, *E*, not less than
    - (1) 0.80 for flanged-end and Standard Class welding-end valves larger than NPS 6
    - (2) 1.00 for Special Class welding-end or threaded-end valves in all sizes (see [para. 8.3.3](#))
    - (3) 1.00 for valves in cryogenic service<sup>3</sup>

These requirements are not applicable to seal welds or attachment welds such as for backseat bushings, seat rings, lifting lugs, and auxiliary connections.

## 2.2 Rating Temperature

The temperature shown for a corresponding pressure rating is the temperature of the pressure-containing shell of the component. In general, this temperature is the same as that of the contained fluid. Use of a pressure rating corresponding to a temperature other than that of the contained fluid is the responsibility of the user, subject to the requirements of applicable codes and regulations.

## 2.3 Temperature Effects

**2.3.1 High Temperature.** Application at temperatures in the creep range will result in decreasing bolt loads as relaxation of flanges, bolts, and gaskets takes place. Flanged joints subject to thermal gradients may likewise be subject to decreasing bolt loads. Decreased bolt loads diminish the capacity of the flanged joint to sustain loads effectively without leakage. At elevated temperatures, flanged joints, and in particular Class 150, may develop leakage problems unless care is taken to avoid imposing severe external loads or severe thermal gradients.

<sup>2</sup> Standard Welding Procedure Specifications published by the American Welding Society and listed in Mandatory Appendix E of the ASME Boiler and Pressure Vessel Code, Section IX are permitted within the limitations established by ASME Boiler and Pressure Vessel Code, Section IX, Article V.

<sup>3</sup> This is applicable only to full-penetration butt welds.

**2.3.2 Low Temperature.** The pressure rating for service at any temperature below  $-29^{\circ}\text{C}$  ( $-20^{\circ}\text{F}$ ) shall be no greater than the rating shown in [Table 2-1.1](#) through [Table 2-3.19](#) for  $-29^{\circ}\text{C}$  ( $-20^{\circ}\text{F}$ ). Some of the materials listed in [Table 1](#), notably some carbon steels, may undergo a decrease in ductility when used at low temperatures to such an extent as to be unable to safely resist shock loading, sudden change of stress, or high stress concentration. Some codes or regulations may require impact testing for applications even where temperatures are higher than  $-29^{\circ}\text{C}$  ( $-20^{\circ}\text{F}$ ). When such requirements apply, it is the responsibility of the user to ensure these requirements are communicated to the manufacturer prior to the time of purchase.

**2.3.3 Fluid Thermal Expansion.** Under certain conditions, some double-seated valve designs are capable of sealing simultaneously against pressure differential from the center cavity to the adjacent pipe in both directions. A circumstance in which the center cavity is filled or partially filled with liquid and subjected to an increase in temperature can result in an excessive buildup of pressure in the center cavity that may lead to pressure boundary failure. An example is a piping system in which liquid from the condensing, cleaning, or testing fluids accumulates in the center cavity of a closed valve. Such accumulation may result from leakage past the upstream seat of the valve. If, during subsequent startup, the valve is not relieved of the liquid by partial opening of the valve or by some other method, the retained liquid may be heated during warm-up of the system. Where such a condition is possible, it is the responsibility of the user to provide, or require to be provided, means in design, installation, or operation procedure to assure that the pressure in the valve will not exceed that allowed by this Standard for the attained temperature.

## 2.4 Guidance for the Use of Flanged Valve Ratings

Application of flanged-end valves at either high or low temperatures or in a service subject to rapid fluid temperature variations entails some risk of flanged joint leakage. Guidance in this regard is provided in ASME B16.5 and more extensively in ASME PCC-1. Precautions regarding the bolting of raised face flanges to cast iron flanges are given in ASME B16.5 and ASME B16.47.

## 2.5 Variances

Except as provided in [paras. 2.5.1, 2.5.2, and 2.5.3](#), the pressure–temperature ratings are the maximum allowable working pressure for the corresponding temperature.

**2.5.1 Safety Valves, Relief Valves, or Rupture Disk Operation.** Under conditions of safety valve, relief valve, or rupture disk operation, pressure may exceed

the rated pressure for a valve furnished under this Standard by no more than 10% of that defined by the pressure–temperature rating. Such conditions are necessarily of limited duration. Damage that may result from pressure excursions in excess of the aforementioned is solely the responsibility of the user.

**2.5.2 Other Variances.** Damage that may result from subjecting a valve to other operating variances (transients) in excess of its pressure rating is solely the responsibility of the user.

**2.5.3 Pressure Testing Limitations.** A valve user who conducts a pressure test or causes a pressure test to be conducted on a valve, either a valve alone or one that is installed in a piping system, needs to be concerned with pressure limits imposed by valves conforming to this Standard.

**2.5.3.1 Valve in the Closed Position.** In the closed position, a valve subjected to a pressure test at a pressure that exceeds its 38°C (100°F) rating, or, if applicable, exceeds the closed position pressure differential limit shown on its identification plate (see [para. 4.3.3](#)), may be damaged. Any damage resulting from such testing is solely the responsibility of the user.

**2.5.3.2 Valve in the Open Position.** In the open position, a valve subjected to a pressure test that exceeds the shell test pressure of [para. 7.1](#) may be damaged. Any damage resulting from such testing is solely the responsibility of the user.

## 2.6 Multiple Material Grades

Material for valve bodies, bonnets, or cover plates may meet the requirements of more than one specification or the requirements of more than one grade of a specification listed in [Table 1](#). In either case, the pressure–temperature ratings for any of these specifications or grades may be used provided the requirements of [para. 5.1](#) are satisfied; the material is marked in accordance with [para. 4.2.8](#); and account is taken of [para. 5.2.2](#).

## 2.7 Local Operating Conditions

When a valve (or series of valves) is installed in a piping system that operates with different pressures (or temperatures) on either side of the closed valve, it is the responsibility of the user to ensure that the installed valve is suitable for the highest of the rating requirements considering combinations of pressure and temperature.

## 3 NOMINAL PIPE SIZE

As applied in this Standard, the use of the phrase “nominal pipe size” or the designation NPS followed by a number is for the purpose of pipe or valve-end connection size identification. The number is not necessarily the

same as the valve inside diameter. The relationship between inside diameter (see [para. 6.1.2](#)) and nominal pipe size is shown in [Nonmandatory Appendix A](#). The reference dimension,  $d$ , in [Table 3A](#) or [Table 3B](#) is the valve inside diameter as defined in [para. 6.1.2](#).

## 4 MARKING

### 4.1 General

Except as modified herein, valves shall be marked as required in MSS SP-25 and shall include the following requirements.

### 4.2 Identification Markings

**4.2.1 Name.** The manufacturer's name or trademark shall be shown.

**4.2.2 Materials.** Materials used for valve bodies, bonnets, and cover plates shall be identified in the following way:

(a) Cast valves shall be marked with the heat number or heat identification and symbols (letters and numbers) as given in the ASTM specification to designate the material grade.

(b) Forged or fabricated valves shall be marked with the ASTM specification number and grade identification symbol (letters and numbers). If the ASTM grade identification symbols are unique to the material product form or grade being used, that is, the symbols are not used with any other ASTM material product form or grade, the ASTM number may be omitted. When more than one material or grade of materials is used for a fabricated valve, each shall be identified. Also, when one material grade is used for a valve assembly, a single material marking on the body is all that is required.

(c) The ASME Boiler and Pressure Vessel Code, Section II specification number may be substituted for a corresponding ASTM specification number in (a) and (b), provided that the requirements of the ASME specification are identical or more stringent than the ASTM specification for the Grade, Class, or Type of material.

(d) A manufacturer may supplement these mandatory material identifications with his trade designation for the material grade, but confusion with the marking required herein shall be avoided.

**4.2.3 Rating.** The valve body shall be marked with the number that corresponds to the pressure rating class designation except that Special Class, Limited Class, Intermediate Rated — Standard Class, and Intermediate Rated — Special Class valves may instead be marked with the valve's maximum allowable temperature and its associated rated pressure.

**4.2.4 Temperature.** Temperature markings are not required except as indicated in [paras. 4.2.3](#) and [4.3.3](#).

**4.2.5 Size.** The NPS designation number shall be shown.

**4.2.6 Omission of Markings.** On valves whose size or shape limits the body markings, they shall be omitted in the following order:

- (a) size
- (b) rating
- (c) material
- (d) manufacturer's name or trademark

**4.2.7 Ring-Joint Flange.** Valves having ring-joint end flanges shall have the edge (periphery) of each ring-joint end flange marked with the letter "R" and the corresponding ring-groove number. Groove numbers are listed in ASME B16.5 and ASME B16.47.

**4.2.8 Multiple Material Marking.** Material for valve bodies, bonnets, and cover plates that meet the requirements for more than one specification or grade of a specification listed in Table 1 may, at the manufacturer's option, be marked with more than one of the applicable specification or grade symbols. These identification markings shall be placed to avoid confusion in identification. The acceptability of multiple marking shall be in accordance with the guidelines set out in ASME Boiler and Pressure Vessel Code, Section II, Part D, Mandatory Appendix 7.

#### 4.3 Identification Plate

**4.3.1 Attachment.** An identification plate that includes the manufacturer's name shall be secured to each valve.

**4.3.2 Pressure Markings.** The identification plate shall be marked with the applicable valve pressure rating at 38°C (100°F) and the pressure rating class designation number.

**4.3.3 Special Markings.** Valves whose construction limits use to less than the pressure-temperature values for the marked pressure rating class designation shall indicate these limitations on the identification plate. Examples in this category are valves using elastomeric gaskets or seating elements, valves with closure elements designed for closure pressure differentials lower than the basic rated pressure of the valve body, or valves using carbon steel bonnet bolts such as ASTM A307, Grade B.

#### 4.4 Conformity

**4.4.1 Designation.** Valves conforming to Standard Class requirements shall include the designation "B16.34" on the identification plate. For Special Class valves, the identification plate shall include the designation "B16.34 SPL." For Limited Class valves, the identification plate shall include the designation "B16.34 LTD." The use of the prefix "ASME" to these designations is optional.

**4.4.2 Compliance.** The "B16.34" identification marking of para. 4.4.1 designates that the valve was manufactured in conformance with ASME B16.34.

### 5 MATERIALS

#### 5.1 General

The body, bonnet or cover, body joint bolting, and body-bonnet or cover bolting shall be constructed of materials as listed in the respective ASTM specifications referred to in Table 1. Identical materials in accordance with the ASME Boiler and Pressure Vessel Code, Section II may also be used for these parts.

**5.1.1 Application.** It is not required that identical material or material form be used for body and bonnet or cover parts. The rating applied, however, shall be based on the valve body. The bonnet or cover shall be designed and material selected so as to comply with the body pressure-temperature rating. Selection of stems, disks, and other parts, such as bonnet gaskets and bolting, subject to pressure and other loading, must be consistent with the applicable valve pressure-temperature rating.

**5.1.2 Carbon Steel Bonnet or Cover Bolting.** It is permissible to use carbon steel, for example, ASTM A307, Grade B, for bonnet or cover bolting only for Class 300 and lower, provided the service temperature is limited to 200°C (400°F) and marking is in accordance with para. 4.3.3.

**5.1.3 Investment Castings.** When investment castings are used for bodies, bonnets, or cover plates of valves NPS 4 and smaller where the ratings do not exceed Class 600, the requirements of the ASTM specifications referred to in Table 1 shall be met, except that it is permissible to determine mechanical and chemical properties from a master heat and to use a 25 mm gage length × 6.25 mm diameter (1 in. × 0.25 in. diameter) tensile specimen in place of the standard 2 in. tensile specimen. A master heat is previously refined metal of a single furnace charge. Tensile specimens shall be cast in molds of the same refractory as the castings and shall be given the same heat treatment as the castings. When investment castings are used for sizes and pressure classes greater than those described in this paragraph, all the requirements of the applicable material specification listed in Table 1 shall be met.

**5.1.4 Cast Surfaces.** Cast surfaces of pressure boundary parts shall be in accordance with MSS SP-55 except that all Type I defects are unacceptable and defects in excess of Plates "a" and "b" for Type II through Type XII are unacceptable.

**5.1.5 Mechanical Properties.** Mechanical properties shall be obtained from test specimens that represent the final heat-treated condition of the material required by the material specification.

## 5.2 Material Selection

(17) **5.2.1 Service Conditions.** Criteria for the selection of materials are not within the scope of this Standard. The possibility of material deterioration in service and the need for periodic inspections is the responsibility of the user. Carbide phase conversion to graphite, oxidation of ferritic materials, decrease in ductility of carbon steels at low temperatures even in applications above  $-10^{\circ}\text{C}$  ( $20^{\circ}\text{F}$ ), and susceptibility to intergranular corrosion of austenitic materials or grain boundary attack of nickel-base alloys are among those items requiring attention by the user. A discussion of precautionary considerations can be found in ASME B31.3, Appendix F; ASME Boiler and Pressure Vessel Code, Section II, Part D, Nonmandatory Appendix A; and ASME Boiler and Pressure Vessel Code, Section III, Division 1, Nonmandatory Appendix W.

**5.2.2 Responsibility.** When service conditions dictate the implementation of special material requirements, e.g., using a Group 2 material above  $538^{\circ}\text{C}$  ( $1,000^{\circ}\text{F}$ ), it is the user's responsibility to so specify to the manufacturer in order to ensure compliance with metallurgical requirements listed in the Notes to [Table 1](#) and the Notes in [Table 2-1.1](#) through [Table 2-3.19](#).

## 5.3 Electrical Continuity

Internal parts that are insulated from the valve body may build up a static electric charge. An example is a ball valve with seats and seals of nonconductive materials. When service conditions require electrical continuity to prevent static discharge, the user is responsible for specifying static grounding.

## 5.4 Flange Removal

When an end flange is removed from a flanged-end valve body casting to make a welding-end valve casting, discontinuities may be observed that would not have been detrimental in the flanged body casting. The valve manufacturer that removes an end flange from a valve body casting during the course of manufacture has responsibility for the acceptability of the resultant welding-end valve casting. This responsibility includes pressure testing the resultant weld-end valve in accordance with [section 7](#).

## 6 DIMENSIONS

### 6.1 Body Dimensions

**6.1.1 Wall Thickness.** For inspection purposes, the wall thickness of valve bodies at the time of manufacture except as indicated in [paras. 6.1.3](#) through [6.1.7](#), [6.2](#), and [6.7](#), shall be no less than the minimum values  $t_m$  either as shown in [Table 3A](#) or [Table 3B](#) or calculated using the equation shown in [Mandatory Appendix VI](#) (which yield essentially the same result). Linear interpolation may be used for wall thickness values intermediate to those listed or calculated. See [Nonmandatory Appendix B, section B-4](#) for an explanation of the interpolation procedure. The minimum thickness requirement for the body wall is applicable only as measured from internal wetted surfaces. Minimum wall thickness determination shall not include liners, linings, or cartridges. (17)

**6.1.2 Inside Diameter.** For the purpose of determining wall thickness,  $t_m$ , using [Table 3A](#) or [Table 3B](#), or the equations in [Mandatory Appendix VI](#), the inside diameter,  $d$ , shall be in accordance with the following requirements: (17)

(a) The inside diameter,  $d$ , shall be the minimum diameter of the flow passage but not less than 90% of the basic inside diameter at the valve end subject to the considerations listed in [\(b\)](#) through [\(f\)](#).

(b) For socket welding- and threaded-end valves, the socket or thread diameters and associated counterbores or threaded bores need not be considered in establishing the value of  $d$  (see [paras. 6.2.3](#) and [6.2.4](#)).

(c) For multipiece valve construction, where the body consists of a central core to which are affixed two end pieces, the inside diameter,  $d$ , is determined by only one of the following methods:

(1) in accordance with [\(a\)](#).

(2) for the end pieces, the value of  $d$  shall be in accordance with [\(a\)](#), and for the central core piece the value of  $d$  shall be the inside diameter of the core piece. For a core piece with axial holes, whether through- or partial-threaded, the inner and outer ligaments shall also meet the requirements of dimensions  $f$  and  $g$  in [Figure 2](#). These ligaments shall be based upon the value of  $d$  for the core piece.

(d) For the special case of valves used between high- and low-pressure sections of a system where an end connection for a thinner pipe wall (or lower Class flange) on one end than on the other, the inside diameter,  $d$ , shall be based on the end connection with the heavier pipe wall (or higher Class flange). The valve wall thickness,  $t_m$ , shall be that associated with the higher Class rating.

(e) Localized variations of inside diameter associated with transitions to weld preparations need not be considered. Note, however, limitations of proximity of body neck in [para. 6.1.5](#).

(f) Where linings, liners, or cartridges are used to form the flow passage or portions of the flow passage, the inside diameter,  $d$ , shall be that at the lining-body, liner-body, or cartridge-body interface.

(g) For inside diameters that lie between diameters listed in Table 3A or Table 3B, the minimum wall thickness,  $t_m$ , may be determined by linear interpolation using the method of para. B-4.4.

**6.1.3 Valve Body Necks.** For inspection purposes, the wall thickness of valve body necks at the time of manufacture shall be no less than the minimum values determined by the following:

(a) Valve body necks, except for the special cases described in (b) through (d), shall maintain the minimum wall thickness as described in paras. 6.1.1 and 6.1.2 within a region of  $1.1\sqrt{dt_m}$  measured from the outside of the body run along the neck direction. The diameter,  $d$ , is as defined in para. 6.1.2, and  $t_m$  is the minimum wall thickness as shown in Table 3A or Table 3B. Minimum wall thickness requirements are applicable to and measured from internally wetted surfaces, e.g., up to the point where the body-bonnet seal is affected.

Beyond the aforementioned  $1.1\sqrt{dt_m}$  region, straight circular sections of valve body necks with inside diameter  $d'$  shall be provided with local wall thickness at least equal to  $t'$  where  $t'$  is taken from the appropriate (tabulated or intermediate) rating Class in Table 3A or Table 3B using an appropriate diameter  $d''$ .

For  $150 \leq \text{Class} \leq 2500$ :

$$d'' = \frac{2d'}{3}$$

For  $2500 < \text{Class} \leq 4500$ :

$$d'' = \frac{d'}{48} \left( 27 + \frac{P_c}{500} \right)$$

where  $P_c$  is the pressure class designation as defined in Nonmandatory Appendix B, para. B-1.3,  $d'$  is the body neck inside diameter, and  $d''$  is the diameter used to determine body neck wall thickness requirement beyond that required for the  $1.1\sqrt{dt_m}$  region.

(b) For the special case where  $d' > 1.5d$ , it is necessary that the wall thickness be equal to or greater than  $t'$  for the entire body neck length having diameter  $d'$ , including the aforementioned  $1.1\sqrt{dt_m}$  region.

(c) For the special case of valve body necks having a small diameter relative to the body run diameter, i.e.,  $d/d' \geq 4$  (for example, a butterfly valve stem penetration), the minimum local wall thickness over a distance,  $L$ , where

$$L = t_m \left( 1 + 1.1 \sqrt{\frac{d}{t_m}} \right)$$

measured starting from the intersection of the body inside diameter and the axis of the body neck outside diameter, shall be equal to  $t'$  where  $t'$  is obtained from Table 3A or Table 3B using the appropriate body neck inside diameter  $d'$  and the appropriate pressure class. This special case is illustrated in Figure 2. Beyond the aforementioned distance,  $L$ , valve body necks shall be provided with local minimum wall thickness based on  $d''$ , in accordance with (a).

(d) For the special case of a body neck in which holes are drilled or tapped in the body neck wall parallel with the body neck axis, it is required that the sum of the ligaments at the inner and outer sides be equal to or greater than  $t_m$  or  $t'$ , as applicable. The inner ligament and the ligament at the bottom of the drill hole shall be no less than  $0.25t_m$  or  $0.25t'$ , as applicable. Furthermore, it is required that this thickness shall extend for a length along the body length, starting at the top of the neck, at least equal to the depth of the hole plus a distance equal to one-half of the hole or bolt diameter.

**6.1.4 Valves With Intermediate Ratings.** The intermediate pressure-temperature rating class designation,  $P_{cl}$ , and minimum wall thickness,  $t_m$ , for threaded- or welding-end valves with intermediate pressure ratings shall be determined in accordance with para. B-4.3 of Nonmandatory Appendix B. For Class 400 flanged-end valves the minimum wall thickness,  $t_m$ , and the intermediate pressure ratings shall be determined by interpolation in accordance with para. B-4.3 of Nonmandatory Appendix B.

**6.1.5 Contours at Body Ends.** Contours at valve body ends shall be in accordance with the following requirements:

(a) *Buttwelding Ends.* The weld preparation (see para. 6.2.1) shall not reduce the body wall thickness to less than the values required by para. 6.1.1 or 6.1.4 within a region closer to the outside surface of the body neck than  $t_m$  measured along the run direction. The transition to the weld preparation shall be gradual, and the section must be essentially circular through the entire length of the transition. Sharp discontinuities or abrupt changes in sections that infringe into the transition shall be avoided, except that test collars or bands, either welded or integral, are allowed. In no case shall the thickness be less than  $0.77t_m$  at a distance of  $2t_m$  from the weld end.

(b) *Socket Welding and Threaded Ends.* The distance from the centerline of generally cylindrical flow passages to the external surface of the body run shall be no less than 0.5 times the appropriate nominal pipe outside diameter listed in ASME B36.10M.

(c) *Completed Ends.* After the tests required by para. 7.1 have been completed, and at the manufacturer's discretion, semifinished buttwelding ends may be machined to final dimensions, flange gasket seating surfaces may be



machined to a final surface finish, or threaded ends may be converted to socket welding ends, all without any additional pressure testing.

**6.1.6 Local Areas.** Local areas having less than minimum wall thickness are acceptable, provided that all of the following limitations are satisfied:

(a) Measured thickness is no less than  $0.75t_o$ .

(b) The area of subminimum thickness can be enclosed by a circle whose diameter is no greater than  $0.35\sqrt{d_o t_o}$ . For valve body necks, use  $d_o = d'$  and  $t_o = t'$  (see para. 6.1.3). For all other local areas, use  $d_o = d$  (see para. 6.1.2) and  $t_o = t_m$  (see para. 6.1.1 or 6.1.4, as appropriate).

(c) Enclosure circles are separated from each other by an edge-to-edge distance of no less than  $1.75\sqrt{d_o t_o}$ .

**6.1.7 Additional Metal Thickness.** Additional metal thickness needed, e.g., for assembly loads, actuating (closing and opening) loads, shapes other than circular, and stress concentrations, must be determined by individual manufacturers since these factors vary widely. In particular, inclined stem valves, intersections and openings in enlarged body cavities, and some types of fabricated body valves may require additional reinforcement to assure adequate strength and rigidity.

## 6.2 End Dimensions

**6.2.1 Butt welding Ends.** Unless otherwise specified by the purchaser, the details of the welding-end preparation shall be in accordance with ASME B16.25 with

(a) the inside diameter (denoted as dimension  $B$  in ASME B16.25) having the following tolerance:

Size	Tolerance for Dimension $B$
NPS $\leq 10$	$\pm 1.0$ mm ( $\pm 0.03$ in.)
$12 \leq \text{NPS} \leq 18$	$\pm 2.0$ mm ( $\pm 0.06$ in.)
$20 \leq \text{NPS}$	$+ 3.0, - 2.0$ mm ( $+ 0.12, - 0.06$ in.)

(b) the outside diameter at welding ends (denoted as dimension  $A$  in ASME B16.25) having a value not less than that shown for wrought or fabricated components.

In all cases, the thickness of the body run or nozzle transition (see para. 6.1.5) starting at a distance  $2t_m$  from the butt welding end, shall be no less than  $0.77t_m$ .

**6.2.2 Flanged Ends.** Flanged ends shall be prepared with flange facing, nut-bearing surfaces, outside diameter, thickness, and drilling in accordance with ASME B16.5 or ASME B16.47, Series A or Series B requirements for

(a) flanged fittings for Class 150 and 300 valves

(b) flanges for Class 600 and higher valves

Large diameter flanges per ASME B16.47 may be Series A or Series B and must be specified by the purchaser. When required, valve end flanges may be furnished with tapped holes for engaging flange bolting. Thread engagement in a flange assembly with tapped holes shall provide full effective thread engagement, not including the chamfered

thread, for a length at least equal to the nominal diameter of the bolt thread. For additional considerations, see para. 6.4.3.

**6.2.3 Socket Welding Ends.** The socket bore diameter, depth of socket, and end surfaces shall be in accordance with ASME B16.11. The minimum thickness of the socket wall extending over the socket depth, including any associated counterbore, shall be in accordance with Table 4.

**6.2.4 Threaded Ends.** End connections shall have taper pipe threads in accordance with ASME B1.20.1. The minimum thickness of the wall extending over the length of an internal thread, including any tap bore or counterbore, shall be in accordance with Table 4. Thread lengths and gaging requirements shall be in accordance with ASME B16.11.

**6.2.5 Intermediate Rated Socket Welding and Threaded-End Valves.** The minimum socket wall thickness and the minimum threaded-end wall thickness for valves with intermediate ratings may be determined by interpolation using the method of para. 6.1.4 using wall thickness values from Table 4.

**6.2.6 End to End.** End-to-end dimensions and face-to-face dimensions for butt welding-end valves and for flanged-end valves shall be in accordance with ASME B16.10 or other dimensions by agreement between manufacturer and purchaser. For some valve types, both long and short pattern dimensions are listed in ASME B16.10. It should not be assumed that all designs of the type listed could be accommodated in the short pattern dimension series. For valve types not included in ASME B16.10, dimensions shall be the manufacturer's standard.

## 6.3 Auxiliary Connections

**6.3.1 General.** Auxiliary connections, e.g., for bypass connections, shall be designed, fabricated, and examined so as to warrant at least the same pressure-temperature ratings as the valve and shall be installed prior to the shell test of the valve to which they are attached, except that upon agreement between the manufacturer and purchaser, auxiliary connections installed after the valve shell tests are acceptable. Welds in auxiliary connections assembled by welding shall be made by a qualified welder using a qualified welding procedure, both in accordance with ASME Boiler and Pressure Vessel Code, Section IX.

**6.3.2 Pipe Thread Tapping.** Threads for threaded auxiliary connections may be tapped into the wall of a valve if the metal is thick enough to allow the effective thread length specified in Figure 3. Where metal thickness is insufficient or the tapped hole needs reinforcement, a boss shall be added as shown in Figure 4.

**6.3.3 Socket Welding.** Sockets for socket welding assembly of auxiliary connections may be provided in the wall of a valve if the metal is thick enough to accommodate the depth of the socket and the thickness of its shoulder specified in Figure 5. Where the metal thickness is insufficient or the socket opening requires reinforcement, a boss shall be added as shown in Figure 4. The length of the leg of the attachment weld shall be not less than 1.09 times the nominal pipe wall thickness of the auxiliary connection or 3.2 mm (0.12 in.), whichever is greater.

**6.3.4 Butt Welding.** Auxiliary connections may be attached by butt welding directly to the wall of the valve (see Figure 6). Where the size of the opening is such that reinforcement is necessary, a boss shall be added as shown in Figure 4.

**6.3.5 Bosses.** Where bosses are required, the inscribed diameters shall be not less than those shown in Figure 4, and the height shall provide metal thickness to satisfy the requirements of Figure 3 or 5.

**6.3.6 Size.** Unless otherwise specified, the minimum auxiliary connection sizes shall be as follows:

Valve Size, NPS	Connection, NPS
$2 \leq \text{NPS} \leq 4$	$\frac{1}{2}$
$4 < \text{NPS} \leq 8$	$\frac{3}{4}$
$8 < \text{NPS}$	1

**6.3.7 Designating Locations.** A means of designating locations for auxiliary connections for some valve types is shown in Figure 1. A letter designates each of these locations so that the desired locations for the illustrated types of valves may be specified without using further sketches or description.

## 6.4 Valve Joints

Valves with bolted or threaded bonnet or cover joints or body joints shall meet the following tensile or shear area requirements.

**6.4.1 Bonnet or Cover Joints.** Valve bonnet or cover joints, the joints between a valve body and a bonnet or cover are joints that are not subject to direct piping loads.

**6.4.1.1 Bolted Bonnet or Cover Joints.** Where bonnets or covers are joined to valve bodies by means of bolting, bolting shall be threaded in accordance with ASME B1.1 for inch bolting or ASME B1.13M for metric bolting and, as a minimum, shall satisfy the following bolt cross-sectional area requirements:

$$P_c \frac{A_g}{A_b} \leq K_1 S_a \leq 9000$$

where

$A_b$  = total effective bolt tensile stress area

$A_g$  = area bounded by the effective outside periphery of a gasket or O-ring or other seal-effective periphery, except that in the case of a ring-joint the bounded area is defined by the pitch diameter of the ring

$K_1$  = 65.26/MPa when  $S_a$  is expressed in MPa units ( $K_1$  = 0.45/psi when  $S_a$  is expressed in psi units)

$P_c$  = pressure rating class designation (see Nonmandatory Appendix B, para. B-1.3)

$S_a$  = allowable bolt stress at 38°C (100°F), MPa (psi). When greater than 137.9 MPa (20,000 psi), use 137.9 MPa (20,000 psi).

The allowable bolt stress values shall be taken from the ASME Boiler and Pressure Vessel Code, Section II, Part D using the listings for Section VIII, Division 1, or Section III, Division 1, Class 2 or Class 3. This algebraic expression requires that a consistent set of units be used.

**6.4.1.2 Threaded Bonnet or Cover Joints.** Where bonnets or covers are joined to valve bodies by means of threads, thread shear area, at a minimum, shall satisfy the following:

$$P_c \frac{A_g}{A_s} \leq 4200$$

where

$A_s$  = total effective thread shear area

**6.4.2 Body Joints.** Valves with bodies of sectional construction such that bolted or threaded body joints are subject to piping mechanical loads shall, at a minimum, satisfy the requirements of paras. 6.4.2.1 and 6.4.2.2.

**6.4.2.1 Bolted Body Joints.** Bolted body joints shall use bolting threaded in accordance with ASME B1.1 for inch dimensional bolting or ASME B1.13M for metric bolting and, at a minimum, shall satisfy the following bolt cross-sectional area requirement:

$$P_c \frac{A_g}{A_b} \leq K_2 S_a \leq 7000$$

where

$K_2$  = 50.76/MPa when  $S_a$  is expressed in MPa units ( $K_2$  = 0.35/psi when  $S_a$  is expressed in psi units)

This algebraic expression requires that a consistent set of units be used.

**6.4.2.2 Threaded Body Joints.** Threaded body joints shall, as a minimum, satisfy the following thread shear area requirement:

$$P_c \frac{A_g}{A_s} \leq 3300$$

**6.4.3 Additional Considerations.** Bolting or threading in excess of the minimum requirements of this Standard may be required because of, for example, valve design, special gasket compression requirements, special specified service conditions, or operation at high temperatures where differences in the creep characteristics between body and bolting materials could compromise joint sealing capability. Since these factors vary widely, these requirements must be accounted for by individual manufacturers.

## 6.5 Stems

Stems, variously referred to as spindles, shafts, or pins, are collectively identified herein as stems.

### 6.5.1 Stem Retention

**6.5.1.1 Retention by Stem Seal Elements.** Valves shall be designed so that the stem seal retaining fasteners (e.g., packing gland fasteners) alone do not retain the stem. Specifically, the design shall be such that the stem shall not be capable of removal from the valve, while the valve is under pressure, by the removal of the stem seal retainer (e.g., gland) alone.

**6.5.1.2 Retention by Closure Member.** Valves, including those intended for isolation, regulation, or flow reversal, shall be provided with a means so that, in the event of a structural failure of stem-to-closure attachment items, the stem will not be ejected through the pressure boundary while the valve is under pressure.

**6.5.1.3 Material Deterioration.** The requirements of [para. 6.5.1.2](#) do not alter the user's responsibility for exercising control over in-service material deterioration or the need for periodic inspections. See [para. 5.2.1](#).

**6.5.2 Position Indication.** Valves of the quarter-turn type (e.g., ball, plug, or butterfly) shall have a means to indicate the ball, plug, or disk position. The design shall be such that the components of the indicating means cannot be assembled to falsely indicate the valve open or closed position.

## 6.6 Installation Limitations

**6.6.1 Single Flange Installation.** Flanged and wafer or flangeless valves are intended for installation between flange pairs. These valves, however, can also be designed for installation against a single flange for the purpose of effecting closure in dead-end piping. Valves for the latter service shall be designed such that those parts necessary to support pressure loads acting across the seating element safely support the maximum differential pressure rating of the valve. Examples of such parts are end entry threaded seat retaining ferrules of ball valves and bolted seat seal retaining plates of butterfly valves. In the event that the valve design cannot accommodate these pressure

loads, then the valve shall be marked to show such installation restriction.

**6.6.2 Disk Clearance.** Valves that can be bolted between flanges or against a flange (e.g., butterfly or swing check valves) may have a disk that will, upon rotation, project beyond the plane of the flange gasket. The valve design shall be such that there will be no interference between the valve disk and companion flanges or adjacent piping for the following pipe schedules:

Pressure Class	Valve Size, NPS	Pipe Schedule
150	2 ≤ NPS ≤ 24	40
300	2 ≤ NPS ≤ 24	80
600	2 ≤ NPS ≤ 6	80
600	8 ≤ NPS ≤ 14	100

For other valve sizes and pressure classes, pipe inside diameter and disk clearance shall be as agreed between manufacturer and purchaser.

## 6.7 Wafer or Flangeless Valves

The design of valves that can be bolted between flanges or against a flange (e.g., butterfly valves) shall conform to the applicable requirements for flanged valves and the requirements of [\(a\)](#) through [\(f\)](#) (see [Figure 2](#)).

*(a)* The design shall provide for boltup using all of the bolt holes and bolt circle of the specified flange.

*(b)* Bolt holes, parallel to the body run, may be either threaded or unthreaded. Threaded holes may be blind holes suitable for use with bolt studs. When threaded, full-thread engagement, excluding chamfers, shall be provided to a depth not less than one nominal bolt diameter.

*(c)* The required minimum valve body wall thickness,  $t_m$ , shall be measured from the valve body inside circumference out to the lesser of the valve body outside circumference or the circumference of a circle inscribed through the inner tangent points to the flange bolt holes.

*(d)* The inner ligament (*e* of [Figure 2](#)) of either a through-hole or a blind threaded hole in the vicinity of a stem penetration shall not be less than 25% of the required wall thickness of the body neck but in no case less than 2.5 mm (0.1 in.).

*(e)* The inner ligament (*f* and *g* of [Figure 2](#)) for holes parallel to the body run shall not be less than  $0.25t_m$  but in no case less than 2.5 mm (0.1 in.). The sum of the inner and outer ligaments shall not be less than  $t_m$ .

*(f)* A ligament within the minimum body wall between two adjacent holes within the minimum body wall (*j* of [Figure 2](#)) shall be  $0.25t_m$  or greater but not less than 2.5 mm (0.1 in.).

## 7 PRESSURE TESTING

### 7.1 Shell Test

**7.1.1 Shell Test Pressure.** Each valve shall be given a shell test at a gage pressure no less than 1.5 times the 38°C (100°F) pressure rating, rounded off to the next higher 1 bar (25 psi) increment. The test shall be made with water, which may contain a corrosion inhibitor, with kerosene, or with other suitable fluid,<sup>4</sup> provided such fluid has viscosity not greater than that of water. The test fluid temperature shall not exceed 50°C (125°F). The test shall be made with the valve in the partially open position.

**7.1.2 Test Duration.** The shell test duration, the test time required for inspection after the valve is fully prepared and is under shell test pressure, shall be not less than the following:

Test Valve Size	Duration, sec
NPS ≤ 2	15
2½ ≤ NPS ≤ 6	60
8 ≤ NPS ≤ 12	120
14 ≤ NPS	300

**7.1.3 Acceptability.** Visually detectable leakage through the pressure boundary is not acceptable. The pressure boundary includes, along with the body, bonnet, or cover, all gasketed joints; however, leakage through the stem seals or stem packing shall not be cause for rejection. Stem seals or stem packing exempted from the shell test pressure leakage requirement shall be capable of retaining pressure up to the 38°C (100°F) pressure rating without visible leakage.

### 7.2 Valve Closure Tests

**7.2.1 Closure Test Pressure.** Each valve designed for shut-off or isolation service, such as a stop valve, and each valve designed for limiting flow reversal, such as a check valve, shall be given a closure test. The closure test shall follow the shell test except that for valves NPS 4 and smaller with ratings Class 1500 and lower the closure test may precede the shell test when a gas closure test is used. The test fluid shall be as in para. 7.1. The test pressure shall be not less than 110% of the 38°C (100°F) pressure rating except that, at the manufacturer's option, a gas closure test at gage pressure not less than 5.5 bar (80 psi) may be substituted for valve sizes and pressure classes as follows:

Valve Size, NPS	Pressure Class
NPS ≤ 4	$P_c \leq 2500$
NPS ≤ 12	$P_c \leq 300$

<sup>4</sup> There are hazards involved when gas is the fluid for testing. When gas is used, appropriate precautions are required.

**7.2.2 Closure Test Duration.** The closure test duration, the time required for inspection after the valve is fully prepared and is under full pressure, shall not be less than the following.

Valve Size	Test Time, sec
NPS ≤ 2	15
2½ ≤ NPS ≤ 8	30
10 ≤ NPS ≤ 18	60
20 ≤ NPS	120

**7.2.3 Closure Test Acceptance.** Closure test leakage acceptance criteria shall be by agreement between manufacturer and purchaser. Closure tightness requirements vary with intended service application and are therefore not within the scope of this Standard. For guidance in this regard, a purchaser has a variety of reference testing sources from which to select closure test criteria. For example, see API Std 598, ISO 5208, or MSS SP-61.

**7.2.4 Double Seating.** For valves of the double seating type, such as most gate-and-ball valves, the test pressure shall be applied successively on each side of the closed valve. The closure test shall include a method that fills the body cavity between the seats and the bonnet cavity with test fluid. As an alternative method, for valves with independent double seating (such as double disk gate valves), the pressure may be applied inside the bonnet or body with the disks closed.

**7.2.5 Directional Seating.** For other valve types, the test pressure shall be applied across the closure member in the direction producing the most adverse seating condition. For example, a globe valve shall be tested with pressure under the disk. A check valve, globe valve, or other valve type designed to be sold and marked as a one-way valve requires a closure test only in the appropriate direction.

**7.2.6 Restricted Seating.** Valves conforming to this Standard in all respects, except that they are designed for operating conditions that have the pressure differential across the closure member limited to values less than the 38°C (100°F) pressure rating and have closure members and/or actuating devices (direct, mechanical, fluid, or electrical) that would be subject to damage at high differential pressures, shall be tested as described in the preceding paragraphs except that the closure test requirement may be reduced to 110% of the maximum specified closed position differential pressure. This exception may be exercised as agreed between the user and manufacturer. The manufacturer's nameplate data shall include reference to any such limitations (see para. 4.3.3).<sup>5</sup>

<sup>5</sup> Performance testing of valve actuating devices is not within the scope of this Standard.

### 7.3 Leakage Detection Devices

Leakage detection devices, e.g., pressure decay devices, may be used for detecting leakage provided that they are used at the pressures required for the shell and closure tests of [paras. 7.1](#) and [7.2](#). When used, the valve manufacturer shall have demonstrated that the test results are equivalent to the requirements of [paras. 7.1](#) and [7.2](#).

### 7.4 Surface Protection

Valves shall not be painted or otherwise coated with materials capable of sealing against leakage before the shell tests are completed except that

(a) internal linings or coatings included in the design, e.g., nonmetal butterfly valve linings, are permitted

(b) chemical corrosion protection treatment is permitted

(c) assembled valves having bodies and bonnets or cover plates that have been separately tested in accordance with [para. 7.1](#), prior to having been painted or coated, may be painted or coated prior to final testing in accordance with [para. 7.1](#)

## 8 REQUIREMENTS FOR SPECIAL CLASS VALVES

### 8.1 Scope

This section defines the nondestructive examination (NDE) requirements and the rules for defect removal and repair for cast, forged, rolled, wrought, and fabricated valve bodies and bonnets or covers that are intended for use in Special Class valves.

### 8.2 General

Nondestructive examinations shall be performed on the cast, forged, rolled, wrought, or fabricated material after heat treatment required by the material specification either prior to or after the finish machining at the option of the manufacturer. Surfaces shall be clean and free of surface conditions that may mask unacceptable indications. Accessible surfaces (see [paras. 8.3.1.2](#) and [8.3.2.2](#)) do not include threads, drilled or threaded holes, for example, for bolting, packing, stems, or auxiliary connections.

### 8.3 Required Examination

#### 8.3.1 Castings

**8.3.1.1 Radiographic Examination.** The radiographic procedures and acceptance standards to be used shall be in accordance with [Mandatory Appendix I](#). Body and bonnet or cover sections requiring radiography are as given in this paragraph and as shown typically in [Figures 7](#) through [17](#). For body and bonnet configurations not represented, it is permissible to construct a composite coverage area based on these illustrations and the descriptions that follow. The distance  $A$  over which film coverage

is required, is expressed in multiples of  $t_m$  where  $t_m$  is the minimum wall thickness requirement as determined by [para. 6.1](#). The value for film coverage of  $A$  is intended to be the greater of  $3t_m$  or 70 mm (2.75 in.). It should be recognized, however, that in some cases the specified value of  $A$  will exceed the intent of the film coverage area as illustrated in [Figures 7](#) through [17](#). For example, in [Figure 12](#) the body neck or run sections may not accommodate the full value of  $A$  as defined. In such cases the requirement may be satisfied by providing film coverage substantially as shown in the sketches. Also, if the full defined coverage width  $A$  would result in the film running substantially into an adjacent fillet or crotch section, the value of  $A$  may be reduced to a practical maximum value. Small variations in coverage are permitted when necessary to accommodate standard film sizes. Film coverage shall include the following areas:

#### (a) Body

(1) a band around each weld end extending back from the body end a distance equal to the greater of  $3t_m$  or 70 mm (2.75 in.)

(2) a band around the bonnet neck extending down from the top of body on pressure seal valves and from back of the flange on bolted bonnet valves a distance equal to the greater of  $3t_m$  or 70 mm (2.75 in.)

(3) a band in the area of the junction between each seat and body shell having a width equal to the greater of  $3t_m$  or 70 mm (2.75 in.) and an encompassing girth extending between the fillets of the intersecting sections, e.g., as shown approximately 210 deg for [Figure 7](#)

(b) *Bonnet.* The junction of the stem seal chamber with the bonnet closure plate or flange.

#### (c) Cover

(1) volumetric examination is not required for flat covers with or without raised faces

(2) for dished covers, a band in the vicinity of the junction between the dished and flanged sections having a width equal to the greater of  $3t_m$  or 70 mm (2.75 in.)

**8.3.1.2 Surface Examination.** All exterior and all accessible interior surfaces of body, bonnet, and cover castings shall be given a surface examination. [Table 1](#), Group 1 materials shall be given either a magnetic particle examination or a liquid penetrant examination. [Table 1](#), Groups 2 and 3 materials shall be given a liquid penetrant examination. Magnetic particle examinations shall be in accordance with the procedure and acceptance standards of [Mandatory Appendix II](#). Liquid penetrant examinations shall be in accordance with the procedure and acceptance standards of [Mandatory Appendix III](#).

**8.3.1.3 Ultrasonic Examination.** An ultrasonic examination of the casting in accordance with [para. 8.3.2.1](#) may be substituted for the radiographic examination, provided that the user agrees and that it can be demonstrated by the manufacturer that the ultrasonic examination produces

interpretable results. The extent of coverage shall be as typically shown in [Figures 7 through 17](#).

### 8.3.2 Forgings, Bars, Plates, and Tubular Products

#### 8.3.2.1 Ultrasonic or Radiographic Examination.

(a) The following material sections shall be ultrasonically examined in accordance with the procedure and acceptance standards in [Mandatory Appendix IV](#) or radiographically examined in accordance with the procedure and acceptance standards in [Mandatory Appendix I](#).

(1) *body*: cylindrical sections at run ends and body neck

(2) *bonnet*: ring section excluding stuffing box and yoke arms

(3) *cover*

(-a) for dished covers, a band in the vicinity of the junction between the dished and flanged sections having a width equal to the greater of  $3t_m$  or 70 mm (2.75 in.)

(-b) volumetric examination is not required for flat covers with or without raised faces

(b) If, during the examination, ultrasonic indications are noninterpretable due to, for example, grain size, the material shall be radiographed using the procedure requirements of [para. 8.3.1.1](#). Subsurface linear indications are unacceptable when they exceed

(1) 4.8 mm (0.19 in.) long in sections under 13 mm (0.5 in.) thick

(2) 9.6 mm (0.38 in.) long in sections 13 mm to 25 mm (0.5 in. to 1 in.) thick

(3) 19.0 mm (0.75 in.) long in sections over 25 mm (1 in.) thick

**8.3.2.2 Surface Examination.** All exterior and all accessible interior surfaces of bodies, bonnets, and covers shall be given a surface examination. [Table 1](#), Group 1 materials shall be given either a magnetic particle examination or a liquid penetrant examination. [Table 1](#), Groups 2 and 3 materials shall be given a liquid penetrant examination. Magnetic particle examinations shall be in accordance with the procedure and acceptance standards of [Mandatory Appendix II](#). Liquid penetrant examinations shall be in accordance with the procedure and acceptance standards of [Mandatory Appendix III](#).

**8.3.3 Welded Fabrication.** Bodies and bonnets made by weld assembly of segments of castings, forgings, bars, tubular products, or plates, or combinations thereof, including fabrication welds, shall be examined as applicable by the methods of [para. 8.3.1](#) for cast components, or [para. 8.3.2](#) for forged, rolled, or wrought components. In addition, all fabrication welds shall receive nondestructive examination in accordance with the

ASME Boiler and Pressure Vessel Code, Section VIII, Division 1, in a manner that results in a weld joint efficiency of 1.0. These requirements are not applicable to welds such as may be used for backseat bushings, seat rings, lifting lugs, and auxiliary connections.

### 8.4 Defect Removal and Repair

**8.4.1 Defect Removal.** Defects in excess of acceptance standards shall be removed by suitable means. If removal of surface defects to an acceptable level does not result in reducing wall thickness below an acceptable value, the area shall be blended smoothly into the surrounding surface.

**8.4.2 Repair by Welding.** Where defect removal results in a wall thickness below an acceptable value, the resultant cavity shall, at the manufacturer's discretion, be scrapped or be repaired by welding, in accordance with the following requirements:

(a) The welding procedure and welding operator are qualified in accordance with ASTM A488 or the ASME Boiler and Pressure Vessel Code, Section IX.

(b) Weld repairs to fabrication welds are made in accordance with the ASME Boiler and Pressure Vessel Code, Section VIII, Division 1.

(c) Weld repairs are heat treated in accordance with the postweld heat treatment requirements of the ASME Boiler and Pressure Vessel Code, Section VIII, Division 1, Subsection C. The exemptions applicable to fabrication welds including groove, fillet, and circumferential butt welds also apply to repair welds. Postweld heat treatment (solution treatment) of repair welds in austenitic stainless steels is neither required nor prohibited except when required by the material specification.

(d) The area is re-examined by the NDE method that originally disclosed the defect. The re-examination by magnetic particle or liquid penetrant methods of a repaired area originally disclosed by magnetic particle or liquid penetrant examination shall be performed after postweld heat treatment when postweld heat treatment is performed. The re-examination by radiography or ultrasonic methods of a repaired area originally disclosed by radiography or ultrasonic examination may be performed either before or after postweld heat treatment when postweld heat treatment is performed. The acceptance standards shall be as in the original examination.

(e) Weld repairs made as a result of radiographic examination shall be radiographed after welding. The acceptance standards for porosity and slag inclusion in welds shall be in accordance with the ASME Boiler and Pressure Vessel Code, Section VIII, Division 1, UW-51.

**Figure 1 Method of Designating Location of Auxiliary Connections When Specified**

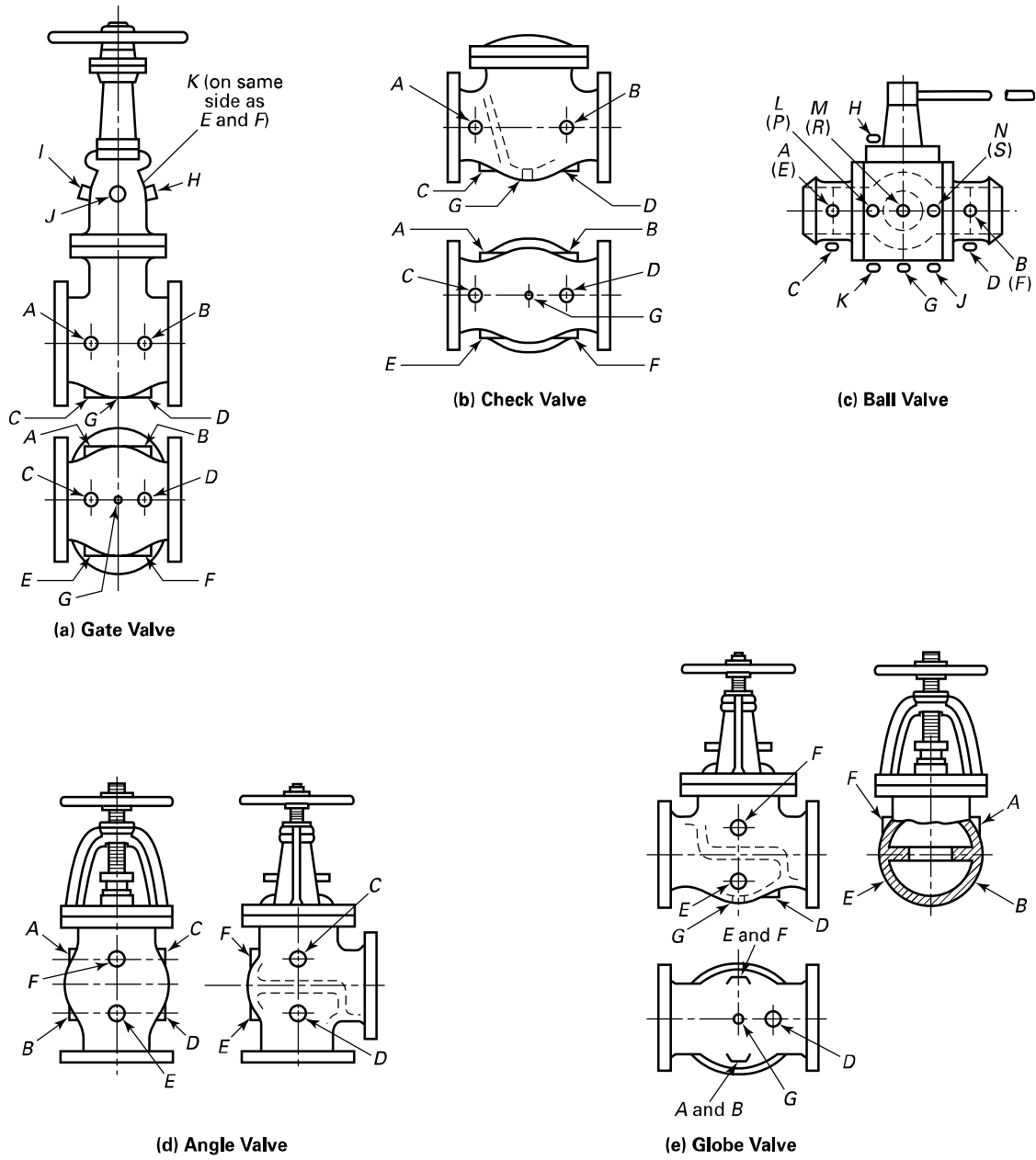

GENERAL NOTE: These sketches represent valves with symmetrical shapes. Sketches are illustrative only and do not imply design (see [para. 6.3.7](#)).





**Figure 3 Thread Length for Auxiliary Connections**

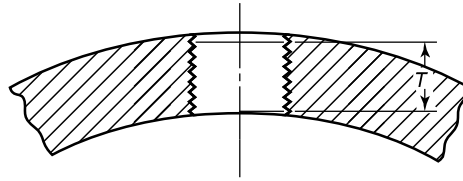

Connection Size, NPS	Minimum Effective Thread Length, <i>T</i> , mm (in.)
$\frac{3}{8}$	10.5 (0.41)
$\frac{1}{2}$	13.5 (0.53)
$\frac{3}{4}$	14.0 (0.55)
1	17.3 (0.68)
$1\frac{1}{4}$	18.0 (0.71)
$1\frac{1}{2}$	18.3 (0.72)
2	19.3 (0.76)

GENERAL NOTES:

(a) See [para. 6.3.2](#).

(b) The minimum thread lengths are for effective threads in accordance with the effective external pipe thread length as given in ASME B1.20.1.

**Figure 4 Bosses for Auxiliary Connections**

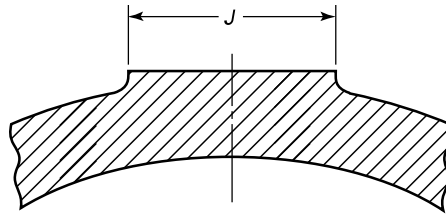

Connection Size, NPS	Nominal Boss Diameter, <i>J</i> , mm (in.)
$\frac{3}{8}$	31 (1.25)
$\frac{1}{2}$	38 (1.50)
$\frac{3}{4}$	44 (1.75)
1	53 (2.12)
$1\frac{1}{4}$	63 (2.50)
$1\frac{1}{2}$	69 (2.75)
2	85 (3.38)

GENERAL NOTE: See [para. 6.3.5](#).

**Figure 5 Socket Welding for Auxiliary Connections**

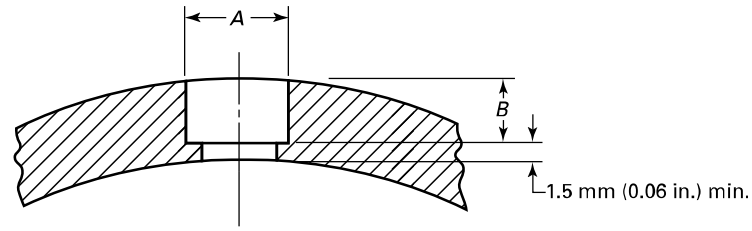

Connection Size, NPS	Minimum Socket Diameter, <i>A</i> , mm (in.)	Minimum Socket Depth, <i>B</i> , mm (in.)
3/8	17.53 (0.690)	4.8 (0.19)
1/2	21.72 (0.855)	4.8 (0.19)
3/4	27.05 (1.065)	6.4 (0.25)
1	33.78 (1.330)	6.4 (0.25)
1 1/4	42.54 (1.675)	6.4 (0.25)
1 1/2	49.53 (1.915)	6.4 (0.25)
2	61.11 (2.406)	7.9 (0.31)

GENERAL NOTE: See [para. 6.3.3](#).

**Figure 6 Butt Welding for Auxiliary Connections**

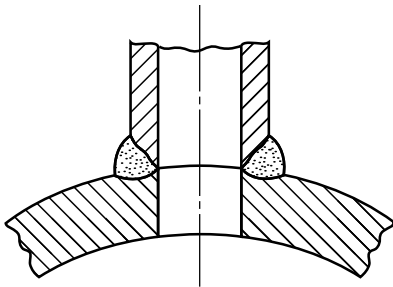

GENERAL NOTE: See [para. 6.3.4](#).

**Figure 7 Gate Body (Pressure Seal Bonnet)**

Typical casting sections showing required radiographic examination

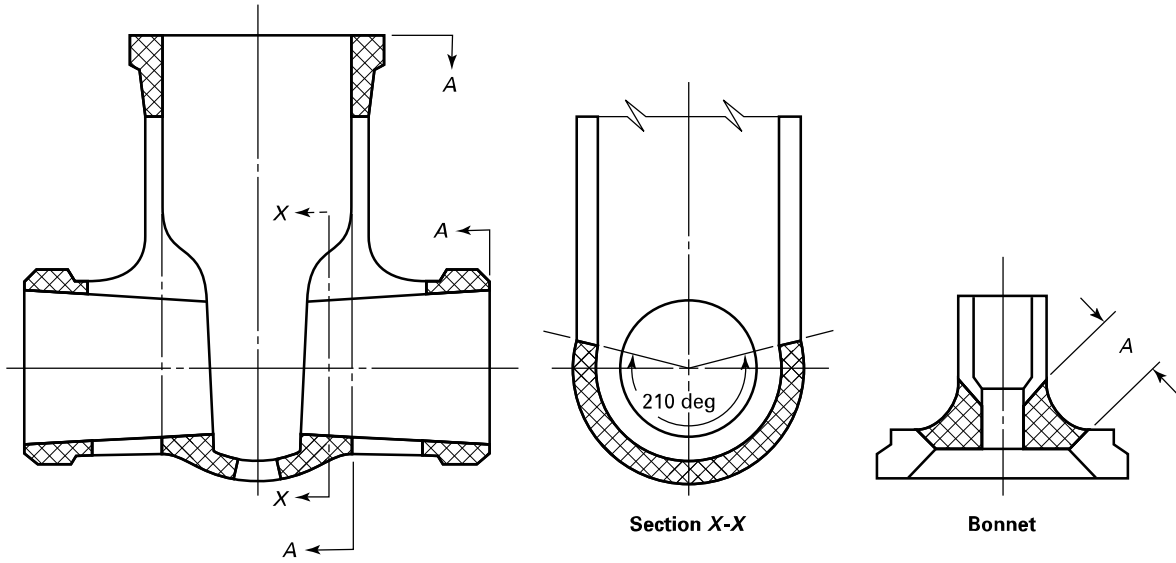

GENERAL NOTE: For definition of A, see [para. 8.3.1.1](#).

**Figure 8 Y Pattern Globe Body (Pressure Seal Bonnet)**

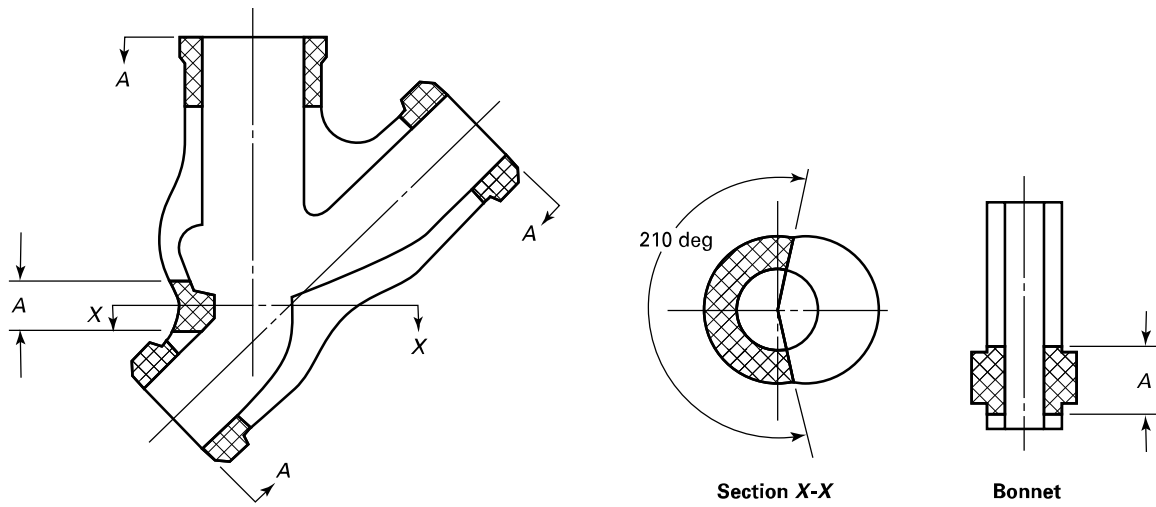

GENERAL NOTE: For definition of A, see [para. 8.3.1.1](#).

**Figure 9 Angle Body (Pressure Seal Bonnet): Bonnet Same As Y Pattern Globe**

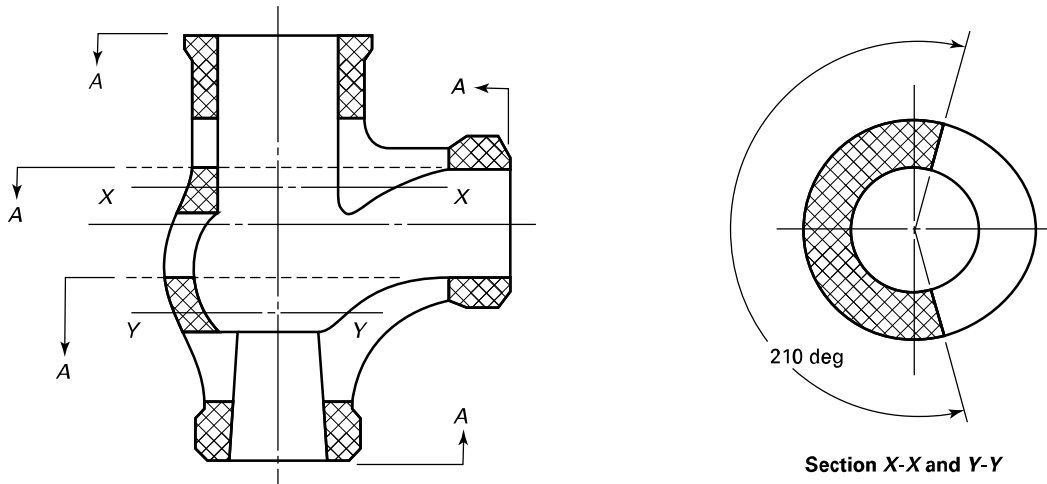

GENERAL NOTE: For definition of A, see [para. 8.3.1.1](#).

**Figure 10 Elbow Down (Pressure Seal Bonnet)**

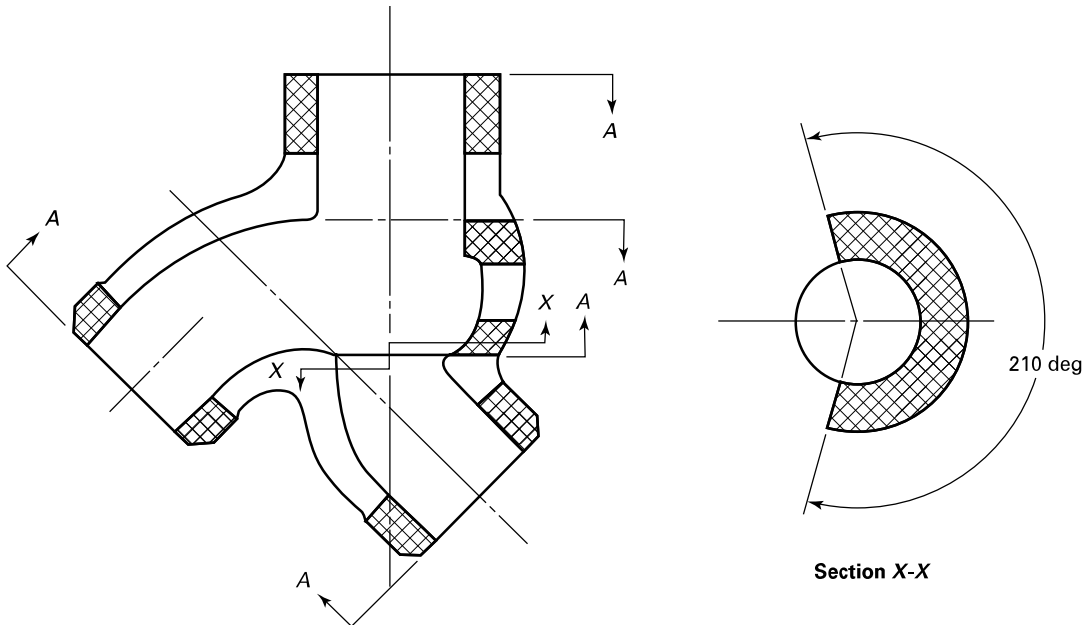

GENERAL NOTE: For definition of A, see [para. 8.3.1.1](#).

Figure 11 Gate Body (Flanged Bonnet)

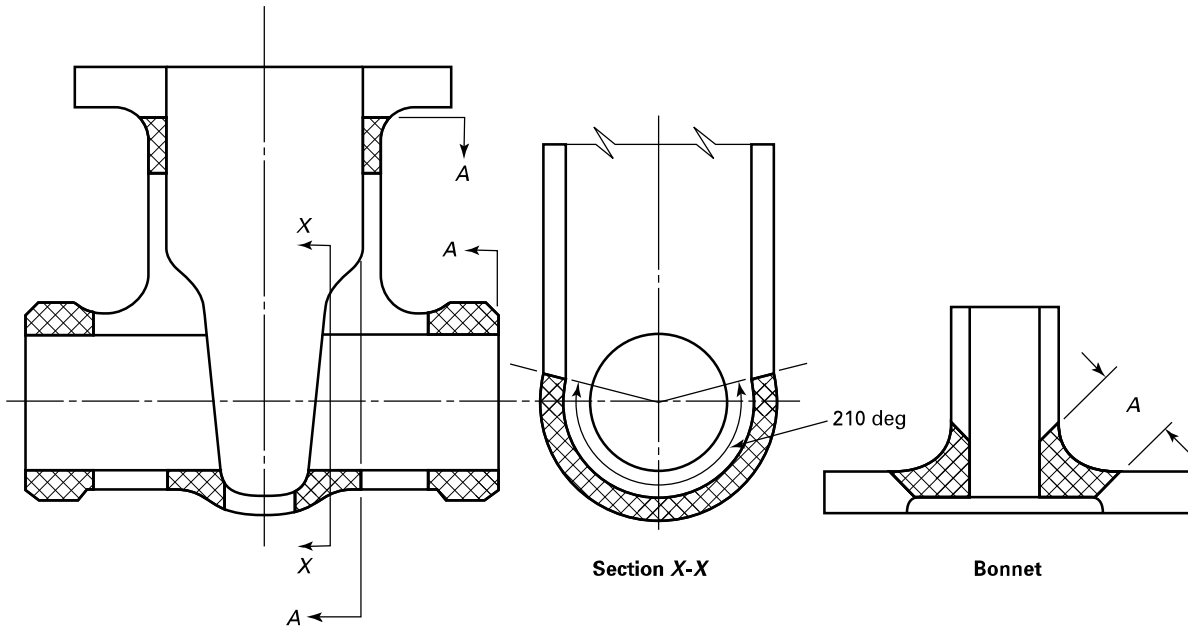

GENERAL NOTE: For definition of A, see [para 8.3.1.1](#).

Figure 12 Globe Body (Flanged Bonnet)

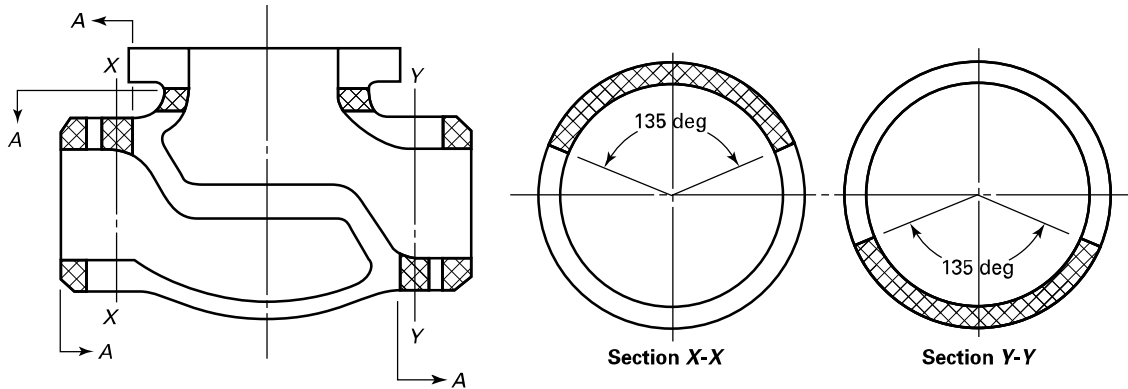

GENERAL NOTE: For definition of A, see [para 8.3.1.1](#).

**Figure 13 Butterfly Body**

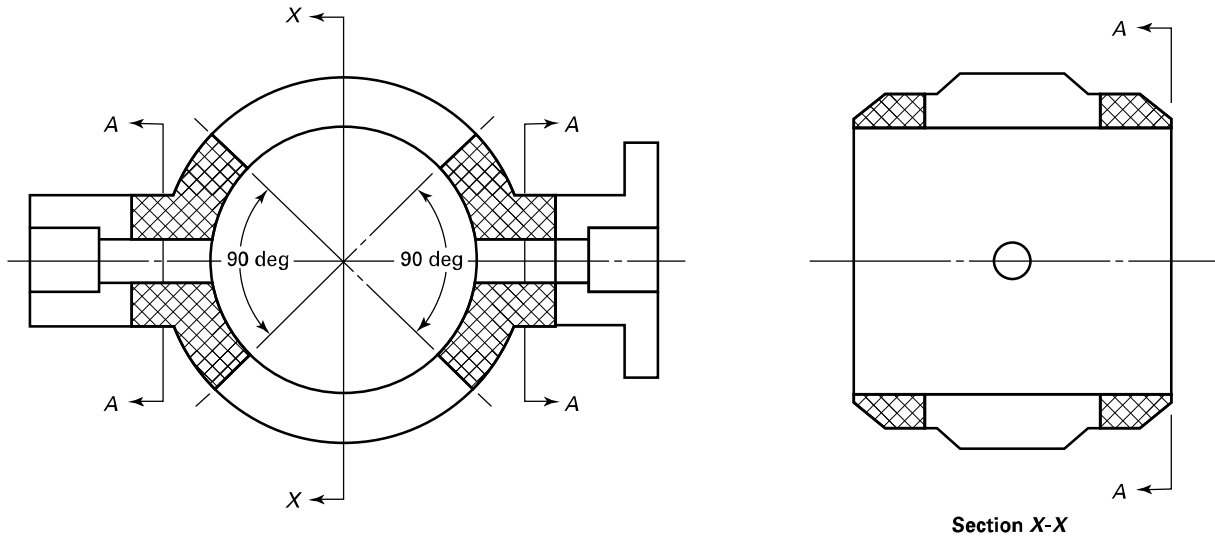

GENERAL NOTE: For definition of A, see [para. 8.3.1.1](#).

**Figure 14 Plug Body**

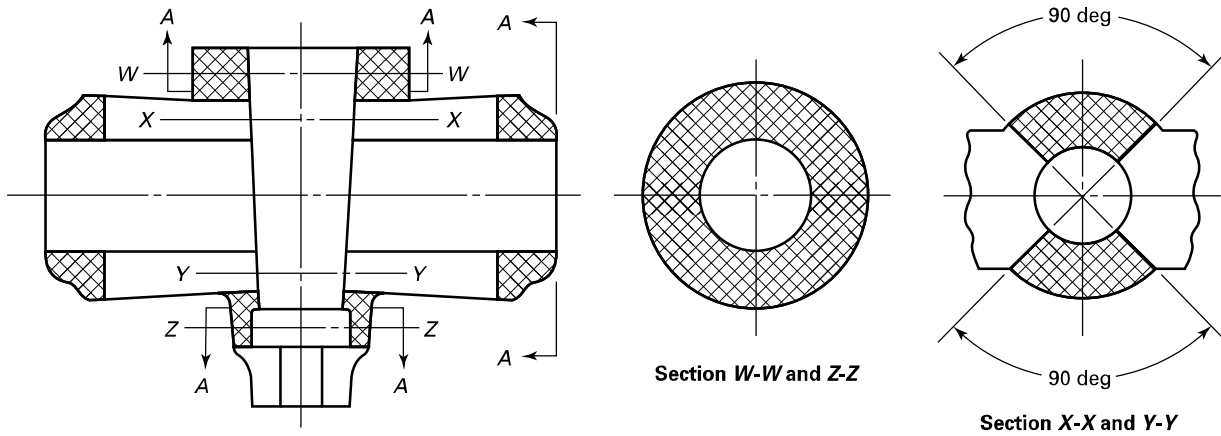

GENERAL NOTE: For definition of A, see [para. 8.3.1.1](#).

**Figure 15 Conduit Gate Body (Pressure Seal Bonnet)**

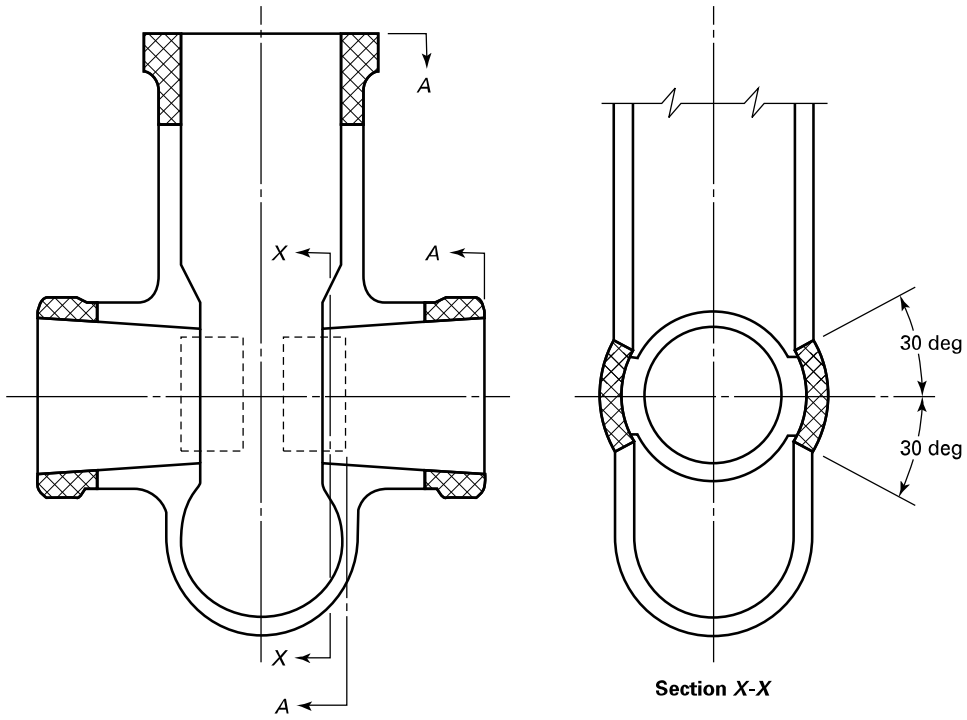

GENERAL NOTE: For definition of *A*, see [para. 8.3.1.1](#).

**Figure 16 Dished Cover**

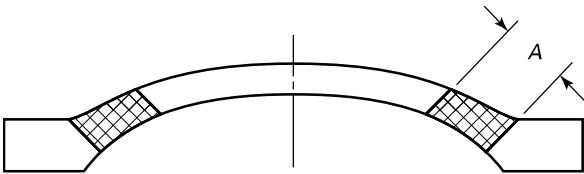

GENERAL NOTE: For definition of *A*, see [para. 8.3.1.1](#).

**Figure 17 Flat Cover**

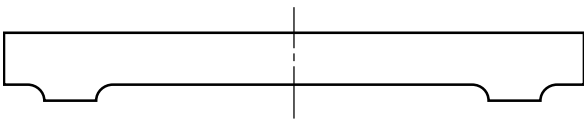

(17)

Table 1 Material Specification List: Applicable ASTM Specifications

Material Group No.	Nominal Designation	Forgings		Castings		Plates		Bars		Tubular	
		Spec. No.	Grade	Spec. No.	Grade	Spec. No.	Grade	Spec. No.	Grade	Spec. No.	Grade
<b>GROUP 1 MATERIALS</b>											
1.1	C-Si	A105	...	A216	WCB	A515	70	A105	...	...	...
	C-Mn-Si	A350	LF2	...	...	A516	70	A350	LF2	A672	C 70
	C-Mn-Si	...	...	...	...	A537	Cl. 1	A696	C	A672	B 70
	3 <sup>1</sup> / <sub>2</sub> Ni	A350	LF3	...	...	...	...	A350	LF3	...	...
	C-Mn-Si-V	A350	LF6 Cl. 1	...	...	...	...	A350	LF6 Cl. 1	...	...
1.2	C-Si	...	...	...	...	...	...	...	...	A106	C
	2 <sup>1</sup> / <sub>2</sub> Ni	...	...	A352	LC2	A203	B	...	...	...	...
	3 <sup>1</sup> / <sub>2</sub> Ni	...	...	A352	LC3	A203	E	...	...	...	...
	C-Mn-Si	...	...	A216	WCC	...	...	...	...	...	...
	C-Mn-Si	...	...	A352	LCC	...	...	...	...	...	...
	C-Mn-Si-V	A350	LF6 Cl. 2	...	...	...	...	A350	LF6 Cl. 2	...	...
1.3	C	...	...	...	...	...	...	A675	70	...	...
	C-Si	...	...	A352	LCB	A515	65	...	...	A672	B 65
	2 <sup>1</sup> / <sub>2</sub> Ni	...	...	...	...	A203	A	...	...	...	...
	3 <sup>1</sup> / <sub>2</sub> Ni	...	...	...	...	A203	D	...	...	...	...
	C-Mn-Si	...	...	...	...	A516	65	...	...	A672	C 65
	C- <sup>1</sup> / <sub>2</sub> Mo	...	...	A217	WC1	...	...	...	...	...	...
	C- <sup>1</sup> / <sub>2</sub> Mo	...	...	A352	LC1	...	...	...	...	...	...
1.4	C	...	...	...	...	...	...	A675	60	...	...
	C	...	...	...	...	...	...	A675	65	...	...
	C-Si	...	...	...	...	A515	60	...	...	A106	B
	C-Si	...	...	...	...	...	...	...	...	A672	B 60
	C-Mn-Si	A350	LF1	...	...	A516	60	A350	LF1	A672	C 60
	C-Mn-Si	...	...	...	...	...	...	A696	B	...	...
1.5	C- <sup>1</sup> / <sub>2</sub> Mo	A182	F1	...	...	A204	A	A182	F1	A691	CM-70
	C- <sup>1</sup> / <sub>2</sub> Mo	...	...	...	...	A204	B	...	...	...	...
1.6	<sup>1</sup> / <sub>2</sub> Cr- <sup>1</sup> / <sub>2</sub> Mo	...	...	...	...	A387	2 Cl. 1	...	...	A691	<sup>1</sup> / <sub>2</sub> CR
	<sup>1</sup> / <sub>2</sub> Cr- <sup>1</sup> / <sub>2</sub> Mo	...	...	...	...	A387	2 Cl. 2	...	...	...	...
1.7	C- <sup>1</sup> / <sub>2</sub> Mo	...	...	...	...	...	...	...	...	A691	CM-75
	<sup>1</sup> / <sub>2</sub> Cr- <sup>1</sup> / <sub>2</sub> Mo	A182	F2	...	...	...	...	A182	F2	...	...
	Ni- <sup>1</sup> / <sub>2</sub> Cr- <sup>1</sup> / <sub>2</sub> Mo	...	...	A217	WC4	...	...	...	...	...	...
	<sup>3</sup> / <sub>4</sub> Ni-Mo- <sup>3</sup> / <sub>4</sub> Cr	...	...	A217	WC5	...	...	...	...	...	...
1.8	1Cr- <sup>1</sup> / <sub>2</sub> Mo	...	...	...	...	A387	12 Cl. 2	...	...	...	...
	1 <sup>1</sup> / <sub>4</sub> Cr- <sup>1</sup> / <sub>2</sub> Mo-Si	...	...	...	...	A387	11 Cl. 1	...	...	A691	1 <sup>1</sup> / <sub>4</sub> CR
	2 <sup>1</sup> / <sub>4</sub> Cr-1Mo	...	...	...	...	A387	22 Cl. 1	...	...	A691	2 <sup>1</sup> / <sub>4</sub> CR
	2 <sup>1</sup> / <sub>4</sub> Cr-1Mo	...	...	...	...	...	...	...	...	A335	P22
	2 <sup>1</sup> / <sub>4</sub> Cr-1Mo	...	...	...	...	...	...	...	...	A369	FP22
1.9	1 <sup>1</sup> / <sub>4</sub> Cr- <sup>1</sup> / <sub>2</sub> Mo-Si	A182	F11 Cl. 2	...	...	A387	11 Cl. 2	A182	F11 Cl. 2	...	...
	1 <sup>1</sup> / <sub>4</sub> Cr- <sup>1</sup> / <sub>2</sub> Mo	...	...	A217	WC6	...	...	A739	B11	...	...
1.10	2 <sup>1</sup> / <sub>4</sub> Cr-1Mo	A182	F22 Cl. 3	A217	WC9	A387	22 Cl. 2	A182	F22 Cl. 3	...	...
	2 <sup>1</sup> / <sub>4</sub> Cr-1Mo	...	...	...	...	...	...	A739	B22	...	...
1.11	3Cr-1Mo	A182	F21	...	...	A387	21 Cl. 2	A182	F21	...	...
	Mn- <sup>1</sup> / <sub>2</sub> Mo	...	...	...	...	A302	A & B	...	...	...	...
	Mn- <sup>1</sup> / <sub>2</sub> Mo- <sup>1</sup> / <sub>2</sub> Ni	...	...	...	...	A302	C	...	...	...	...
	Mn- <sup>1</sup> / <sub>2</sub> Mo- <sup>3</sup> / <sub>4</sub> Ni	...	...	...	...	A302	D	...	...	...	...
	C-Mn-Si	...	...	...	...	A537	CL2	...	...	...	...
	C- <sup>1</sup> / <sub>2</sub> Mo	...	...	...	...	A204	C	...	...	...	...



(17)

**Table 1 Material Specification List: Applicable ASTM Specifications (Cont'd)**

Material Group No.	Nominal Designation	Forgings		Castings		Plates		Bars		Tubular	
		Spec. No.	Grade	Spec. No.	Grade	Spec. No.	Grade	Spec. No.	Grade	Spec. No.	Grade
<b>GROUP 1 MATERIALS (Cont'd)</b>											
1.12	5Cr- $\frac{1}{2}$ Mo	...	...	...	...	A387	5 Cl. 1	...	...	A691	5CR
	5Cr- $\frac{1}{2}$ Mo	...	...	...	...	A387	5 Cl. 2	...	...	A335	P5
	5Cr- $\frac{1}{2}$ Mo	...	...	...	...	...	...	...	...	A369	FP5
	5Cr- $\frac{1}{2}$ Mo-Si	...	...	...	...	...	...	...	...	A335	P5b
1.13	5Cr- $\frac{1}{2}$ Mo	A182	F5a	A217	C5	...	...	A182	F5a	...	...
1.14	9Cr-1Mo	A182	F9	A217	C12	...	...	A182	F9	...	...
1.15	9Cr-1Mo-V	A182	F91	A217	C12A	A387	91 Cl. 2	A182	F91	A335	P91
1.16	C- $\frac{1}{2}$ Mo	...	...	...	...	...	...	...	...	A335	P1
	C- $\frac{1}{2}$ Mo	...	...	...	...	...	...	...	...	A369	FP1
	1Cr- $\frac{1}{2}$ Mo	...	...	...	...	A387	12 Cl. 1	...	...	A691	1CR
	1Cr- $\frac{1}{2}$ Mo	...	...	...	...	...	...	...	...	A335	P12
	1Cr- $\frac{1}{2}$ Mo	...	...	...	...	...	...	...	...	A369	FP12
	1 $\frac{1}{4}$ Cr- $\frac{1}{2}$ Mo-Si	...	...	...	...	...	...	...	...	A335	P11
	1 $\frac{1}{4}$ Cr- $\frac{1}{2}$ Mo-Si	...	...	...	...	...	...	...	...	A369	FP11
1.17	1Cr- $\frac{1}{2}$ Mo	A182	F12 Cl. 2	...	...	...	...	A182	F12 Cl. 2	...	...
	5Cr- $\frac{1}{2}$ Mo	A182	F5	...	...	...	...	A182	F5	...	...
1.18	9Cr-2W-V	A182	F92	...	...	...	...	A182	F92	A335	P92
	9Cr-2W-V	...	...	...	...	...	...	...	...	A369	FP92
<b>GROUP 2 MATERIALS</b>											
2.1	18Cr-8Ni	...	...	A351	CF3	...	...	...	...	...	...
	18Cr-8Ni	A182	F304	A351	CF8	A240	304	A182	F304	A312	TP304
	18Cr-8Ni	A182	F304H	A351	CF10	A240	304H	A182	F304H	A312	TP304H
	18Cr-8Ni	...	...	...	...	...	...	A479	304	A358	304
	18Cr-8Ni	...	...	...	...	...	...	A479	304H	A376	TP304
	18Cr-8Ni	...	...	...	...	...	...	...	...	A376	TP304H
	18Cr-8Ni	...	...	...	...	...	...	...	...	A430	FP304
	18Cr-8Ni	...	...	...	...	...	...	...	...	A430	FP304H
2.2	16Cr-12Ni-2Mo	...	...	A351	CF3M	...	...	...	...	...	...
	16Cr-12Ni-2Mo	A182	F316	A351	CF8M	A240	316	A182	F316	A312	TP316
	16Cr-12Ni-2Mo	A182	F316H	A351	CF10M	A240	316H	A182	F316H	A312	TP316H
	16Cr-12Ni-2Mo	...	...	...	...	...	...	A479	316	A358	316
	16Cr-12Ni-2Mo	...	...	...	...	...	...	A479	316H	A376	TP316
	16Cr-12Ni-2Mo	...	...	...	...	...	...	...	...	A376	TP316H
	16Cr-12Ni-2Mo	...	...	...	...	...	...	...	...	A430	FP316
	16Cr-12Ni-2Mo	...	...	...	...	...	...	...	...	A430	FP316H
	18Cr-8Ni	...	...	A351	CF3A	...	...	...	...	...	...
	18Cr-8Ni	...	...	A351	CF8A	...	...	...	...	...	...
	18Cr-13Ni-3Mo	A182	F317	...	...	A240	317	...	...	A312	TP317
	19Cr-10Ni-3Mo	...	...	A351	CG8M	...	...	...	...	...	...
19Cr-10Ni-3Mo	...	...	A351	CG3M	...	...	...	...	...	...	
2.3	18Cr-8Ni	A182	F304L	...	...	A240	304L	A182	F304L	A312	TP304L
	18Cr-8Ni	...	...	...	...	...	...	A479	304L	...	...
	16Cr-12Ni-2Mo	A182	F316L	...	...	A240	316L	A182	F316L	A312	TP316L
	16Cr-12Ni-2Mo	...	...	...	...	...	...	A479	316L	...	...
	18Cr-13Ni-3Mo	A182	F317L	...	...	...	...	A182	F317L	...	...
2.4	18Cr-10Ni-Ti	A182	F321	...	...	A240	321	A182	F321	A312	TP321

(17)

**Table 1 Material Specification List: Applicable ASTM Specifications (Cont'd)**

Material Group No.	Nominal Designation	Forgings		Castings		Plates		Bars		Tubular	
		Spec. No.	Grade	Spec. No.	Grade	Spec. No.	Grade	Spec. No.	Grade	Spec. No.	Grade
<b>GROUP 2 MATERIALS (Cont'd)</b>											
	18Cr-10Ni-Ti	A182	F321H	...	...	A240	321H	A479	321	A312	TP321H
	18Cr-10Ni-Ti	...	...	...	...	...	...	A182	F321H	A358	321
	18Cr-10Ni-Ti	...	...	...	...	...	...	A479	321H	A376	TP321
	18Cr-10Ni-Ti	...	...	...	...	...	...	...	...	A376	TP321H
	18Cr-10Ni-Ti	...	...	...	...	...	...	...	...	A430	FP321
	18Cr-10Ni-Ti	...	...	...	...	...	...	...	...	A430	FP321H
2.5	18Cr-10Ni-Cb	A182	F347	...	...	A240	347	A182	F347	A312	TP347
	18Cr-10Ni-Cb	A182	F347H	...	...	A240	347H	A182	F347H	A312	TP347H
	18Cr-10Ni-Cb	A182	F348	...	...	A240	348	A182	F348	A312	TP348
	18Cr-10Ni-Cb	A182	F348H	...	...	A240	348H	A182	F348H	A312	TP348H
	18Cr-10Ni-Cb	...	...	...	...	...	...	A479	347	A358	TP347
	18Cr-10Ni-Cb	...	...	...	...	...	...	A479	347H	A376	TP347
	18Cr-10Ni-Cb	...	...	...	...	...	...	A479	348	A376	TP347H
	18Cr-10Ni-Cb	...	...	...	...	...	...	A479	348H	A376	TP348
	18Cr-10Ni-Cb	...	...	...	...	...	...	...	...	A376	TP348H
	18Cr-10Ni-Cb	...	...	...	...	...	...	...	...	A430	FP347
	18Cr-10Ni-Cb	...	...	...	...	...	...	...	...	A430	FP347H
2.6	23Cr-12Ni	...	...	...	...	...	...	...	...	A312	TP309H
	23Cr-12Ni	...	...	...	...	A240	309H	...	...	A358	309H
2.7	25Cr-20Ni	A182	F310H	...	...	A240	310H	A182	F310H	A312	TP310H
	25Cr-20Ni	...	...	...	...	...	...	A479	310H	A358	310H
2.8	20Cr-18Ni-6Mo	A182	F44	A351	CK3MCuN	A240	S31254	A182	F44	A312	S31254
	20Cr-18Ni-6Mo	...	...	...	...	...	...	A479	S31254	A358	S31254
	22Cr-5Ni-3Mo-N	A182	F51	A995	CD3MN	A240	S31803	A182	F51	A789	S31803
	22Cr-5Ni-3Mo-N	...	...	...	...	...	...	A479	S31803	A790	S31803
	25Cr-7Ni-4Mo-N	A182	F53	...	...	A240	S32750	A182	F53	A789	S32750
	25Cr-7Ni-4Mo-N	...	...	...	...	...	...	A479	S32750	A790	S32750
	24Cr-10Ni-4Mo-N	...	...	A995	CE8MN	...	...	...	...	...	...
	25Cr-5Ni-3Cu-2Mo-N	...	...	A995	CD4MCuN	...	...	...	...	...	...
	25Cr-7Ni-3.5Mo-W-N	...	...	A995	CD3MWCuN	...	...	...	...	...	...
	25Cr-7.5Ni-3.5Mo-N-Cu-W	A182	F55	...	...	A240	S32760	A479	S32760	A790	S32760
2.9	23Cr-12Ni	...	...	...	...	A240	309S	...	...	...	...
	25Cr-20Ni	...	...	...	...	A240	310S	A479	310S	...	...
2.10	25Cr-12Ni	...	...	A351	CH8	...	...	...	...	...	...
	25Cr-12Ni	...	...	A351	CH20	...	...	...	...	...	...
2.11	18Cr-10Ni-Cb	...	...	A351	CF8C	...	...	...	...	...	...
2.12	25Cr-20Ni	...	...	A351	CK20	...	...	...	...	...	...
<b>GROUP 3 MATERIALS</b>											
3.1	35Ni-35Fe-20Cr-Cb	B462	N08020	...	...	B463	N08020	B462	N08020	...	...
	35Ni-35Fe-20Cr-Cb	...	...	...	...	...	...	B473	N08020	B464	N08020
	35Ni-35Fe-20Cr-Cb	...	...	...	...	...	...	...	...	B468	N08020
3.2	99Ni	B564	N02200	...	...	B162	N02200	B160	N02200	B161	N02200
	99Ni	...	...	...	...	...	...	...	...	B163	N02200
3.3	99Ni-Low C	...	...	...	...	B162	N02201	B160	N02201	...	...
3.4	67Ni-30Cu	B564	N04400	...	...	B127	N04400	B164	N04400	B165	N04400
	67Ni-30Cu	...	...	A494	M-35-1	...	...	...	...	B163	N04400

(17)

**Table 1 Material Specification List: Applicable ASTM Specifications (Cont'd)**

Material Group No.	Nominal Designation	Forgings		Castings		Plates		Bars		Tubular	
		Spec. No.	Grade	Spec. No.	Grade	Spec. No.	Grade	Spec. No.	Grade	Spec. No.	Grade
<b>GROUP 3 MATERIALS (Cont'd)</b>											
	67Ni-30Cu-S	...	...	A494	M-35-2	...	...	B164	N04405	...	...
3.5	72Ni-15Cr-8Fe	B564	N06600	...	...	B168	N06600	B166	N06600	...	...
	72Ni-15Cr-8Fe	...	...	...	...	...	...	...	...	B163	N06600
3.6	33Ni-42Fe-21Cr	B564	N08800	...	...	B409	N08800	B408	N08800	B163	N08800
3.7	65Ni-28Mo-2Fe	B462	N10665	...	...	B333	N10665	B335	N10665	...	...
	65Ni-28Mo-2Fe	...	...	...	...	...	...	B462	N10665	B622	N10665
	65Ni-28Mo-2Fe	B564	N10665	...	...	...	...	...	...	...	...
	64Ni-29.5Mo-2Cr-2Fe-Mn-W	B462	N10675	...	...	B333	N10675	B335	N10675	...	...
	64Ni-29.5Mo-2Cr-2Fe-Mn-W	...	...	...	...	...	...	B462	N10675	B622	N10675
	64Ni-29.5Mo-2Cr-2Fe-Mn-W	B564	N10675	...	...	...	...	...	...	...	...
3.8	54Ni-16Mo-15Cr	B462	N10276	...	...	B575	N10276	B462	N10276	...	...
	54Ni-16Mo-15Cr	...	...	...	...	...	...	B574	N10276	B622	N10276
	54Ni-16Mo-15Cr	B564	N10276	...	...	...	...	...	...	...	...
	60Ni-22Cr-9Mo-3.5Cb	B564	N06625	...	...	B443	N06625	B446	N06625	...	...
	62Ni-28Mo-5Fe	...	...	...	...	B333	N10001	B335	N10001	B622	N10001
	70Ni-16Mo-7Cr-5Fe	...	...	...	...	B434	N10003	B573	N10003	...	...
	61Ni-16Mo-16Cr	...	...	...	...	B575	N06455	B574	N06455	B622	N06455
	42Ni-21.5Cr-3Mo-2.3Cu	B564	N08825	...	...	B424	N08825	B425	N08825	B423	N08825
	55Ni-21Cr-13.5Mo	B462	N06022	...	...	B575	N06022	B462	N06022	B622	N06022
	55Ni-21Cr-13.5Mo	B564	N06022	...	...	...	...	B574	N06022	...	...
	55Ni-23Cr-16Mo-1.6Cu	B462	N06200	...	...	B575	N06200	B574	N06200	B622	N06200
	55Ni-23Cr-16Mo-1.6Cu	B564	N06200	...	...	...	...	...	...	...	...
3.9	47Ni-22Cr-9Mo-18Fe	...	...	...	...	B435	N06002	B572	N06002	B622	N06002
	21Ni-30Fe-22Cr-18Co-3Mo-3W	...	...	...	...	B435	R30556	B572	R30556	B622	R30556
3.10	25Ni-47Fe-21Cr-5Mo	...	...	...	...	B599	N08700	B672	N08700	...	...
3.11	44Fe-25Ni-21Cr-Mo	...	...	...	...	B625	N08904	B649	N08904	B677	N08904
3.12	26Ni-43Fe-22Cr-5Mo	...	...	...	...	B620	N08320	B621	N08320	B622	N08320
	47Ni-22Cr-20Fe-7Mo	...	...	...	...	B582	N06985	B581	N06985	B622	N06985
	46Fe-24Ni-21Cr-6Mo-Cu-N	B462	N08367	A351	CN3MN	B688	N08367	B462	N08367	...	...
	46Fe-24Ni-21Cr-6Mo-Cu-N	...	...	...	...	...	...	B691	N08367	...	...
	58Ni-33Cr-8Mo	B462	N06035	...	...	B575	N06035	B462	N06035	B622	N06035
	58Ni-33Cr-8Mo	B564	N06035	...	...	...	...	B574	N06035	...	...
3.13	49Ni-25Cr-18Fe-6Mo	...	...	...	...	B582	N06975	B581	N06975	B622	N06975
	Ni-Fe-Cr-Mo-Cu-Low C	B564	N08031	...	...	B625	N08031	B649	N08031	B622	N08031
3.14	47Ni-22Cr-19Fe-6Mo	...	...	...	...	B582	N06007	B581	N06007	B622	N06007
	40Ni-29Cr-15Fe-5Mo	B462	N06030	...	...	B582	N06030	B462	N06030	...	...
	40Ni-29Cr-15Fe-5Mo	...	...	...	...	...	...	B581	N06030	B622	N06030
3.15	42Ni-2Fe-21Cr	B564	N08810	...	...	B409	N08810	B408	N08810	B407	N08810
	Ni-Mo	...	...	A494	N-12MV	...	...	...	...	...	...
	Ni-Mo-Cr	...	...	A494	CW-12MW	...	...	...	...	...	...
3.16	35Ni-19Cr-1¼Si	...	...	...	...	B536	N08330	B511	N08330	B535	N08330
3.17	29Ni-20½Cr-3½Cu-2½Mo	...	...	A351	CN7M	...	...	...	...	...	...
3.18	72Ni-15Cr-8Fe	...	...	...	...	...	...	...	...	B167	N06600
3.19	57Ni-22Cr-14W-2Mo-La	B564	N06230	...	...	B435	N06230	B572	N06230	B622	N06230

(17)

**Table 1 Material Specification List: Applicable ASTM Specifications (Cont'd)**

GROUP 4 MATERIALS					
Bolting Materials [Note (1)]					
Specification Number	Grade	Notes	Specification Number	Grade	Notes
A193	...	(2), (3)	B164	...	(10)–(12)
A307B	...	(4), (5)	B166	...	(10), (11)
A320	...	(2), (3), (6)	B335	N10665	(10)
A354	...	...	B335	N10675	(10)
A449	...	(7), (8)	B408	...	(10)–(12)
A453	651 and 660	(9)	B473	...	(10)
A540	...	...	B574	N10276	(10)
A564	630	(7)	B574	N06022	(10)
			B637	N07718	(10)

## GENERAL NOTES:

- (a) The user is responsible for assuring that bolting material is not used beyond limits specified in governing codes or regulations.  
 (b) ASME Boiler and Pressure Vessel Code Section II materials that also meet the requirements of the listed ASTM specification may also be used.  
 (c) Material limitations, restrictions, and special requirements are shown in the pressure–temperature tables, [Table 2-1.1](#) through [Table 2-3.19](#).

## NOTES:

- (1) Repair welding of bolting material is not permitted.  
 (2) Where austenitic bolting materials have been carbide-solution treated but not strain hardened, they are designated Class 1 or Class 1A in ASTM A193. ASTM A194 nuts of corresponding material are recommended.  
 (3) Where austenitic bolting materials have been carbide-solution treated and strain hardened, they are designated Class 2, 2B, or 2C in ASTM A193. ASTM A194 nuts of corresponding material are recommended.  
 (4) For limitations of usage and strength level, see [para. 5.1.2](#).  
 (5) Bolts with drilled or undersize heads shall not be used.  
 (6) For ferritic bolting materials intended for service at low temperature, ASTM A194 Grade 7 nuts are recommended.  
 (7) Acceptable nuts for use with quenched and tempered steel bolts are ASTM A194 Grade 2 and 2H.  
 (8) Mechanical property requirements for studs shall be the same as for bolts.  
 (9) Bolting materials suitable for high-temperature service with austenitic stainless steel valve materials.  
 (10) Nuts may be of the same material or may be of compatible grade of ASTM A194.  
 (11) Forging quality not permitted unless the producer last heating or working these parts tests them as required for other permitted conditions in the same specification and certifies their final tensile, yield, and elongation properties to equal or exceed the requirements for one of the other permitted conditions.  
 (12) Maximum operating temperature is arbitrarily set at 260°C (500°F), unless material has been annealed, solution annealed, or hot finished, because hard temper adversely affects design stress in the creep-rupture temper range.

**Table 2-1.1 Ratings for Group 1.1 Materials**

A105 (1), (2)	A350 Gr. LF3 (6)	A516 Gr. 70 (1), (4)	A672 Gr. B70 (1)
A216 Gr. WCB (1)	A350 Gr. LF6 Cl. 1 (5)	A537 Cl. 1 (3)	A672 Gr. C70 (1)
A350 Gr. LF2 (1)	A515 Gr. 70 (1)	A696 Gr. C (3)	

**A — Standard Class**

Temperature, °C	Working Pressures by Class, bar						
	150	300	600	900	1500	2500	4500
-29 to 38	19.6	51.1	102.1	153.2	255.3	425.5	765.9
50	19.2	50.1	100.2	150.4	250.6	417.7	751.9
100	17.7	46.6	93.2	139.8	233.0	388.3	699.0
150	15.8	45.1	90.2	135.2	225.4	375.6	676.1
200	13.8	43.8	87.6	131.4	219.0	365.0	657.0
250	12.1	41.9	83.9	125.8	209.7	349.5	629.1
300	10.2	39.8	79.6	119.5	199.1	331.8	597.3
325	9.3	38.7	77.4	116.1	193.6	322.6	580.7
350	8.4	37.6	75.1	112.7	187.8	313.0	563.5
375	7.4	36.4	72.7	109.1	181.8	303.1	545.5
400	6.5	34.7	69.4	104.2	173.6	289.3	520.8
425	5.5	28.8	57.5	86.3	143.8	239.7	431.5
450	4.6	23.0	46.0	69.0	115.0	191.7	345.1
475	3.7	17.4	34.9	52.3	87.2	145.3	261.5
500	2.8	11.8	23.5	35.3	58.8	97.9	176.3
538	1.4	5.9	11.8	17.7	29.5	49.2	88.6

**B — Special Class**

Temperature, °C	Working Pressures by Class, bar						
	150	300	600	900	1500	2500	4500
-29 to 38	19.8	51.7	103.4	155.1	258.6	430.9	775.7
50	19.8	51.7	103.4	155.1	258.6	430.9	775.7
100	19.8	51.6	103.3	154.9	258.2	430.3	774.5
150	19.6	51.0	102.1	153.1	255.2	425.3	765.5
200	19.4	50.6	101.1	151.7	252.9	421.4	758.6
250	19.4	50.5	101.1	151.6	252.6	421.1	757.9
300	19.4	50.5	101.1	151.6	252.6	421.1	757.9
325	19.2	50.1	100.2	150.3	250.6	417.6	751.7
350	18.7	48.9	97.8	146.7	244.6	407.6	733.7
375	18.1	47.1	94.2	141.3	235.5	392.5	706.5
400	16.6	43.4	86.8	130.2	217.0	361.7	651.0
425	13.8	36.0	71.9	107.9	179.8	299.6	539.3
450	11.0	28.8	57.5	86.3	143.8	239.6	431.4
475	8.4	21.8	43.6	65.4	109.0	181.6	326.9
500	5.6	14.7	29.4	44.1	73.5	122.4	220.4
538	2.8	7.4	14.8	22.2	36.9	61.6	110.8

NOTES:

- (1) Upon prolonged exposure to temperatures above 425°C, the carbide phase of steel may be converted to graphite. Permissible, but not recommended for prolonged usage above 425°C.
- (2) Only killed steel shall be used above 455°C.

**Table 2-1.1 Ratings for Group 1.1 Materials (Cont'd)**

---

NOTES (Cont'd):

- (3) Not to be used over 370°C.
- (4) Not to be used over 455°C.
- (5) Not to be used over 260°C.
- (6) Not to be used over 345°C.

**Table 2-1.2 Ratings for Group 1.2 Materials**

A106 Gr. C (1)	A203 Gr. E (2)	A350 Gr. LF6 Cl. 2 (3)	A352 Gr. LC3 (4)
A203 Gr. B (2)	A216 Gr. WCC (2)	A352 Gr. LC2 (4)	A352 Gr. LCC (4)

**A — Standard Class**

Temperature, °C	Working Pressures by Class, bar						
	150	300	600	900	1500	2500	4500
-29 to 38	19.8	51.7	103.4	155.1	258.6	430.9	775.7
50	19.5	51.7	103.4	155.1	258.6	430.9	775.7
100	17.7	51.5	103.0	154.6	257.6	429.4	773.0
150	15.8	50.2	100.3	150.5	250.8	418.1	752.6
200	13.8	48.6	97.2	145.8	243.2	405.4	729.7
250	12.1	46.3	92.7	139.0	231.8	386.2	694.8
300	10.2	42.9	85.7	128.6	214.4	357.1	642.6
325	9.3	41.4	82.6	124.0	206.6	344.3	619.6
350	8.4	40.0	80.0	120.1	200.1	333.5	600.3
375	7.4	37.8	75.7	113.5	189.2	315.3	567.5
400	6.5	34.7	69.4	104.2	173.6	289.3	520.8
425	5.5	28.8	57.5	86.3	143.8	239.7	431.5
450	4.6	23.0	46.0	69.0	115.0	191.7	345.1
475	3.7	17.1	34.2	51.3	85.4	142.4	256.3
500	2.8	11.6	23.2	34.7	57.9	96.5	173.7
538	1.4	5.9	11.8	17.7	29.5	49.2	88.6

**B — Special Class**

Temperature, °C	Working Pressures by Class, bar						
	150	300	600	900	1500	2500	4500
-29 to 38	20.0	51.7	103.4	155.1	258.6	430.9	775.7
50	20.0	51.7	103.4	155.1	258.6	430.9	775.7
100	20.0	51.7	103.4	155.1	258.6	430.9	775.7
150	20.0	51.7	103.4	155.1	258.6	430.9	775.7
200	20.0	51.7	103.4	155.1	258.6	430.9	775.7
250	20.0	51.7	103.4	155.1	258.6	430.9	775.7
300	20.0	51.7	103.4	155.1	258.6	430.9	775.7
325	20.0	51.7	103.4	155.1	258.6	430.9	775.7
350	19.8	51.1	102.2	153.3	255.5	425.8	766.4
375	19.3	48.4	96.7	145.1	241.9	403.1	725.6
400	19.3	43.4	86.8	130.2	217.0	361.7	651.0
425	18.0	36.0	71.9	107.9	179.8	299.6	539.3
450	14.4	28.8	57.5	86.3	143.8	239.6	431.4
475	10.7	21.4	42.7	64.1	106.8	178.0	320.4
500	7.2	14.5	29.0	43.4	72.4	120.7	217.2
538	3.7	7.4	14.8	22.2	36.9	61.6	110.8

NOTES:

- (1) Not to be used over 425°C.
- (2) Upon prolonged exposure to temperatures above 425°C, the carbide phase of steel may be converted to graphite. Permissible, but not recommended for prolonged usage above 425°C.
- (3) Not to be used over 260°C.

**Table 2-1.2 Ratings for Group 1.2 Materials (Cont'd)**

---

NOTES (Cont'd):

(4) Not to be used over 345°C.



**Table 2-1.3 Ratings for Group 1.3 Materials**

A203 Gr. A (1)	A352 Gr. LCB (2)	A516 Gr. 65 (1), (3)	A672 Gr. C65 (1)				
A203 Gr. D (1)	A352 Gr. LC1 (2)	A672 Gr. B65 (1)	A675 Gr. 70 (1), (4), (5)				
A217 Gr. WC1 (6)-(8)	A515 Gr. 65 (1)						
<b>A — Standard Class</b>							
<b>Temperature, °C</b>	<b>Working Pressures by Class, bar</b>						
	<b>150</b>	<b>300</b>	<b>600</b>	<b>900</b>	<b>1500</b>	<b>2500</b>	<b>4500</b>
-29 to 38	18.4	48.0	96.0	144.1	240.1	400.1	720.3
50	18.2	47.5	94.9	142.4	237.3	395.6	712.0
100	17.4	45.3	90.7	136.0	226.7	377.8	680.1
150	15.8	43.9	87.9	131.8	219.7	366.1	659.1
200	13.8	42.5	85.1	127.6	212.7	354.4	638.0
250	12.1	40.8	81.6	122.3	203.9	339.8	611.7
300	10.2	38.7	77.4	116.1	193.4	322.4	580.3
325	9.3	37.6	75.2	112.7	187.9	313.1	563.7
350	8.4	36.4	72.8	109.2	182.0	303.3	545.9
375	7.4	35.0	69.9	104.9	174.9	291.4	524.6
400	6.5	32.6	65.2	97.9	163.1	271.9	489.3
425	5.5	27.3	54.6	81.9	136.5	227.5	409.5
450	4.6	21.6	43.2	64.8	107.9	179.9	323.8
475	3.7	15.7	31.3	47.0	78.3	130.6	235.0
500	2.8	11.1	22.1	33.2	55.4	92.3	166.1
538	1.4	5.9	11.8	17.7	29.5	49.2	88.6
<b>B — Special Class</b>							
<b>Temperature, °C</b>	<b>Working Pressures by Class, bar</b>						
	<b>150</b>	<b>300</b>	<b>600</b>	<b>900</b>	<b>1500</b>	<b>2500</b>	<b>4500</b>
-29 to 38	20.0	48.0	96.0	144.1	240.1	400.1	720.3
50	20.0	48.0	96.0	144.1	240.1	400.1	720.3
100	20.0	48.0	96.0	144.1	240.1	400.1	720.3
150	20.0	48.0	96.0	144.1	240.1	400.1	720.3
200	20.0	48.0	96.0	144.1	240.1	400.1	720.3
250	20.0	48.0	96.0	144.1	240.1	400.1	720.3
300	20.0	48.0	96.0	144.1	240.1	400.1	720.3
325	20.0	48.0	95.9	143.9	239.8	399.6	719.3
350	19.8	47.3	94.6	141.9	236.5	394.1	709.4
375	19.3	44.9	89.9	134.8	224.7	374.6	674.2
400	19.3	40.8	81.6	122.3	203.9	339.8	611.7
425	17.1	34.1	68.3	102.4	170.6	284.4	511.9
450	13.5	27.0	54.0	81.0	134.9	224.9	404.8
475	9.8	19.6	39.2	58.8	97.9	163.2	293.8
500	6.9	13.8	27.7	41.5	69.2	115.3	207.6
538	3.7	7.4	14.8	22.2	36.9	61.6	110.8

## NOTES:

- (1) Upon prolonged exposure to temperatures above 425°C, the carbide phase of steel may be converted to graphite. Permissible, but not recommended for prolonged usage above 425°C.
- (2) Not to be used over 345°C.

**Table 2-1.3 Ratings for Group 1.3 Materials (Cont'd)**

---

NOTES (Cont'd):

- (3) Not to be used over 455°C.
- (4) Leaded grades shall not be used where welded or in any application above 260°C.
- (5) For service temperatures above 455°C, it is recommended that killed steels containing not less than 0.10% residual silicon be used.
- (6) Upon prolonged exposure to temperatures above 470°C, the carbide phase of steel of carbon-molybdenum steel may be converted to graphite. Permissible, but not recommended for prolonged usage above 470°C.
- (7) Use normalized and tempered material only.
- (8) The deliberate addition of any element not listed in ASTM A217, Table 1 is prohibited, except that calcium (Ca) and manganese (Mn) may be added for deoxidation.

**Table 2-1.4 Ratings for Group 1.4 Materials**

		A515 Gr. 60 (1), (2)	A672 Gr. C60 (1)			A675 Gr. 65 (1), (3), (4)	
		A516 Gr. 60 (1), (2)	A675 Gr. 60 (1)–(3)			A696 Gr. B (5)	
		A — Standard Class					
Temperature, °C	Working Pressures by Class, bar						
	150	300	600	900	1500	2500	4500
-29 to 38	16.3	42.6	85.1	127.7	212.8	354.6	638.3
50	16.0	41.8	83.5	125.3	208.9	348.1	626.6
100	14.9	38.8	77.7	116.5	194.2	323.6	582.5
150	14.4	37.6	75.1	112.7	187.8	313.0	563.4
200	13.8	36.4	72.8	109.2	182.1	303.4	546.2
250	12.1	34.9	69.8	104.7	174.6	291.0	523.7
300	10.2	33.2	66.4	99.5	165.9	276.5	497.7
325	9.3	32.2	64.5	96.7	161.2	268.6	483.5
350	8.4	31.2	62.5	93.7	156.2	260.4	468.7
375	7.4	30.4	60.7	91.1	151.8	253.0	455.3
400	6.5	29.3	58.7	88.0	146.7	244.5	440.1
425	5.5	25.8	51.5	77.3	128.8	214.7	386.5
450	4.6	21.4	42.7	64.1	106.8	178.0	320.4
475	3.7	14.1	28.2	42.3	70.5	117.4	211.4
500	2.8	10.3	20.6	30.9	51.5	85.9	154.6
538	1.4	5.9	11.8	17.7	29.5	49.2	88.6
		B — Special Class					
Temperature, °C	Working Pressures by Class, bar						
	150	300	600	900	1500	2500	4500
-29 to 38	17.0	44.3	88.6	133.0	221.6	369.4	664.9
50	17.0	44.3	88.6	133.0	221.6	369.4	664.9
100	17.0	44.3	88.6	133.0	221.6	369.4	664.9
150	17.0	44.3	88.6	133.0	221.6	369.4	664.9
200	17.0	44.3	88.6	133.0	221.6	369.4	664.9
250	17.0	44.3	88.6	133.0	221.6	369.4	664.9
300	16.5	43.0	86.0	129.0	215.0	358.3	644.9
325	16.1	42.0	83.9	125.9	209.9	349.8	629.6
350	15.6	40.7	81.4	122.1	203.4	339.1	610.3
375	15.2	39.5	79.1	118.6	197.6	329.4	592.9
400	14.6	38.2	76.3	114.5	190.8	317.9	572.3
425	12.4	32.3	64.6	96.9	161.5	269.2	484.5
450	10.2	26.7	53.4	80.1	133.5	222.5	400.5
475	6.8	17.6	35.2	52.9	88.1	146.8	264.3
500	4.9	12.9	25.8	38.7	64.4	107.4	193.3
538	2.8	7.4	14.8	22.2	36.9	61.6	110.8

## NOTES:

- (1) Upon prolonged exposure to temperatures above 425°C, the carbide phase of steel may be converted to graphite. Permissible, but not recommended for prolonged usage above 425°C.
- (2) Not to be used over 455°C.

**Table 2-1.4 Ratings for Group 1.4 Materials (Cont'd)**

---

NOTES (Cont'd):

(3) Lead grades shall not be used where welded or in any application above 260°C.

(4) For service temperatures above 455°C, it is recommended that killed steels containing not less than 0.10% residual silicon be used.

(5) Not to be used over 370°C.

**Table 2-1.5 Ratings for Group 1.5 Materials**

A182 Gr. F1 (1)	A204 Gr. B (1)	A691 Gr. CM-70 (1)					
A204 Gr. A (1)							
A — Standard Class							
Temperature, °C	Working Pressures by Class, bar						
	150	300	600	900	1500	2500	4500
-29 to 38	18.4	48.0	96.0	144.1	240.1	400.1	720.3
50	18.4	48.0	96.0	144.1	240.1	400.1	720.3
100	17.7	47.9	95.9	143.8	239.7	399.5	719.1
150	15.8	47.3	94.7	142.0	236.7	394.5	710.1
200	13.8	45.8	91.6	137.4	229.0	381.7	687.1
250	12.1	44.5	89.0	133.5	222.5	370.9	667.6
300	10.2	42.9	85.7	128.6	214.4	357.1	642.6
325	9.3	41.4	82.6	124.0	206.6	344.3	619.6
350	8.4	40.3	80.4	120.7	201.1	335.3	603.3
375	7.4	38.9	77.6	116.5	194.1	323.2	581.8
400	6.5	36.5	73.3	109.8	183.1	304.9	548.5
425	5.5	35.2	70.0	105.1	175.1	291.6	524.7
450	4.6	33.7	67.7	101.4	169.0	281.8	507.0
475	3.7	31.7	63.4	95.1	158.2	263.9	474.8
500	2.8	24.1	48.1	72.2	120.3	200.5	361.0
538	1.4	11.3	22.7	34.0	56.7	94.6	170.2
B — Special Class							
Temperature, °C	Working Pressures by Class, bar						
	150	300	600	900	1500	2500	4500
-29 to 38	18.4	48.0	96.0	144.1	240.1	400.1	720.3
50	18.4	48.0	96.0	144.1	240.1	400.1	720.3
100	18.4	48.0	96.0	144.1	240.1	400.1	720.3
150	18.4	48.0	96.0	144.1	240.1	400.1	720.3
200	18.4	48.0	96.0	144.1	240.1	400.1	720.3
250	18.4	48.0	96.0	144.1	240.1	400.1	720.3
300	18.4	48.0	96.0	144.1	240.1	400.1	720.3
325	18.4	48.0	96.0	144.1	240.1	400.1	720.3
350	18.4	48.0	96.0	144.1	240.1	400.1	720.3
375	18.4	48.0	96.0	144.1	240.1	400.1	720.3
400	18.4	48.0	96.0	144.1	240.1	400.1	720.3
425	18.4	48.0	96.0	144.1	240.1	400.1	720.3
450	18.1	47.3	94.4	141.4	235.8	393.1	707.6
475	16.4	42.8	85.5	128.2	213.7	356.3	641.3
500	11.5	30.1	60.2	90.2	150.4	250.7	451.2
538	5.4	14.2	28.4	42.6	70.9	118.2	212.8

NOTE: (1) Upon prolonged exposure to temperatures above 470°C, the carbide phase of steel of carbon-molybdenum steel may be converted to graphite. Permissible, but not recommended for prolonged usage above 470°C.

**Table 2-1.6 Ratings for Group 1.6 Materials**

A387 Gr. 2 Cl. 1	A387 Gr. 2 Cl. 2	A691 Gr. ½CR					
<b>A — Standard Class</b>							
Temperature, °C	Working Pressures by Class, bar						
	150	300	600	900	1500	2500	4500
-29 to 38	15.6	40.6	81.3	121.9	203.1	338.6	609.4
50	15.6	40.6	81.3	121.9	203.1	338.6	609.4
100	15.6	40.6	81.3	121.9	203.1	338.6	609.4
150	15.6	40.6	81.3	121.9	203.1	338.6	609.4
200	13.8	40.6	81.3	121.9	203.1	338.6	609.4
250	12.1	39.8	79.5	119.3	198.8	331.4	596.4
300	10.2	38.7	77.3	116.0	193.3	322.1	579.8
325	9.3	38.1	76.1	114.2	190.3	317.1	570.8
350	8.4	37.4	74.8	112.2	187.1	311.8	561.2
375	7.4	36.8	73.5	110.3	183.8	306.3	551.4
400	6.5	36.0	72.0	108.0	179.9	299.9	539.8
425	5.5	35.1	70.0	105.1	175.1	291.6	524.7
450	4.6	33.7	67.7	101.4	169.0	281.8	507.0
475	3.7	31.7	63.4	95.1	158.2	263.9	474.8
500	2.8	25.7	51.3	77.0	128.3	213.9	384.9
538	1.4	13.9	27.9	41.8	69.7	116.2	209.2
<b>B — Special Class</b>							
Temperature, °C	Working Pressures by Class, bar						
	150	300	600	900	1500	2500	4500
-29 to 38	15.6	40.6	81.3	121.9	203.1	338.6	609.4
50	15.6	40.6	81.3	121.9	203.1	338.6	609.4
100	15.6	40.6	81.3	121.9	203.1	338.6	609.4
150	15.6	40.6	81.3	121.9	203.1	338.6	609.4
200	15.6	40.6	81.3	121.9	203.1	338.6	609.4
250	15.6	40.6	81.3	121.9	203.1	338.6	609.4
300	15.6	40.6	81.3	121.9	203.1	338.6	609.4
325	15.6	40.6	81.3	121.9	203.1	338.6	609.4
350	15.6	40.6	81.3	121.9	203.1	338.6	609.4
375	15.6	40.6	81.3	121.9	203.1	338.6	609.4
400	15.6	40.6	81.3	121.9	203.1	338.6	609.4
425	15.6	40.6	81.3	121.9	203.1	338.6	609.4
450	15.6	40.6	81.3	121.9	203.1	338.6	609.4
475	15.6	40.6	81.3	121.9	203.1	338.6	609.4
500	12.3	32.0	64.1	96.1	160.1	266.9	480.4
538	6.7	17.4	34.9	52.3	87.2	145.3	261.5

**Table 2-1.7 Ratings for Group 1.7 Materials**

A182 Gr. F2 (1)	A217 Gr. WC4 (1)-(3)		A217 Gr. WC5 (2)		A691 Gr. CM-75		
<b>A — Standard Class</b>							
Temperature, °C	Working Pressures by Class, bar						
	150	300	600	900	1500	2500	4500
-29 to 38	19.8	51.7	103.4	155.1	258.6	430.9	775.7
50	19.5	51.7	103.4	155.1	258.6	430.9	775.7
100	17.7	51.5	103.0	154.6	257.6	429.4	773.0
150	15.8	50.3	100.3	150.6	250.8	418.2	752.8
200	13.8	48.6	97.2	145.8	243.4	405.4	729.8
250	12.1	46.3	92.7	139.0	231.8	386.2	694.8
300	10.2	42.9	85.7	128.6	214.4	357.1	642.6
325	9.3	41.4	82.6	124.0	206.6	344.3	619.6
350	8.4	40.3	80.4	120.7	201.1	335.3	603.3
375	7.4	38.9	77.6	116.5	194.1	323.2	581.8
400	6.5	36.5	73.3	109.8	183.1	304.9	548.5
425	5.5	35.2	70.0	105.1	175.1	291.6	524.7
450	4.6	33.7	67.7	101.4	169.0	281.8	507.0
475	3.7	31.7	63.4	95.1	158.2	263.9	474.8
500	2.8	26.7	53.4	80.1	133.4	222.4	400.3
538	1.4	13.9	27.9	41.8	69.7	116.2	209.2
550	1.4 (4)	12.6	25.2	37.8	63.0	105.0	188.9
575	1.4 (4)	7.2	14.4	21.5	35.9	59.8	107.7
<b>B — Special Class</b>							
Temperature, °C	Working Pressures by Class, bar						
	150	300	600	900	1500	2500	4500
-29 to 38	19.8	51.7	103.4	155.1	258.6	430.9	775.7
50	19.8	51.7	103.4	155.1	258.6	430.9	775.7
100	19.8	51.7	103.4	155.1	258.6	430.9	775.7
150	19.8	51.7	103.4	155.1	258.6	430.9	775.7
200	19.8	51.7	103.4	155.1	258.6	430.9	775.7
250	19.8	51.7	103.4	155.1	258.6	430.9	775.7
300	19.8	51.7	103.4	155.1	258.6	430.9	775.7
325	19.8	51.7	103.4	155.1	258.6	430.9	775.7
350	19.8	51.5	102.8	154.3	257.1	428.6	771.4
375	19.3	50.6	101.0	151.5	252.5	420.9	757.4
400	19.3	50.3	100.6	150.6	251.2	418.3	753.2
425	19.0	49.6	99.3	148.9	248.2	413.7	744.6
450	18.1	47.3	94.4	141.4	235.8	393.1	707.6
475	16.4	42.8	85.5	128.2	213.7	356.3	641.3
500	12.8	33.4	66.7	100.1	166.8	278.0	500.3
538	6.7	17.4	34.9	52.3	87.2	145.3	261.5
550	6.0	15.7	31.5	47.2	78.7	131.2	236.2
575	3.4	9.0	17.9	26.9	44.9	74.8	134.6

NOTES:

(1) Not to be used over 538°C.

**Table 2-1.7 Ratings for Group 1.7 Materials (Cont'd)**

---

NOTES (Cont'd):

- (2) Use normalized and tempered material only.
- (3) The deliberate addition of any element not listed in ASTM A217, Table 1 is prohibited, except that calcium (Ca) and manganese (Mn) may be added for deoxidation.
- (4) For welding-end valves only. Class 150 flanged-end valves terminate at 538°C.



**Table 2-1.8 Ratings for Group 1.8 Materials**

A335 Gr. P22 (1)	A387 Gr. 11 Cl. 1 (1)	A387 Gr. 22 Cl. 1 (1)	A691 Gr. 2¼CR (1)
A369 Gr. FP 22 (1)	A387 Gr. 12 Cl. 2 (1)	A691 Gr. 1¼CR (1)	

**A — Standard Class**

Temperature, °C	Working Pressures by Class, bar						
	150	300	600	900	1500	2500	4500
-29 to 38	16.3	42.6	85.1	127.7	212.8	354.6	638.3
50	16.1	41.9	83.9	125.8	209.6	349.4	628.9
100	15.2	39.6	79.2	118.7	197.9	329.8	593.7
150	14.8	38.6	77.1	115.7	192.9	321.4	578.6
200	13.8	38.2	76.4	114.6	190.9	318.2	572.8
250	12.1	38.2	76.3	114.5	190.8	317.9	572.3
300	10.2	38.2	76.3	114.5	190.8	317.9	572.3
325	9.3	38.2	76.3	114.5	190.8	317.9	572.3
350	8.4	38.0	76.0	114.0	189.9	316.5	569.8
375	7.4	37.3	74.7	112.0	186.7	311.2	560.2
400	6.5	36.5	73.3	109.8	183.1	304.9	548.5
425	5.5	35.2	70.0	105.1	175.1	291.6	524.7
450	4.6	33.7	67.7	101.4	169.0	281.8	507.0
475	3.7	31.7	63.4	95.1	158.2	263.9	474.8
500	2.8	25.6	51.3	76.9	128.2	213.7	384.7
538	1.4	14.9	29.8	44.7	74.5	124.1	223.4
550	1.4 (2)	12.7	25.4	38.1	63.5	105.9	190.6
575	1.4 (2)	8.8	17.6	26.4	44.0	73.4	132.0
600	1.4 (2)	6.1	12.1	18.2	30.3	50.4	90.8
625	1.4 (2)	4.0	8.0	12.1	20.1	33.5	60.4
650	1.0 (2)	2.6	5.2	7.8	13.0	21.7	39.0

**B — Special Class**

Temperature, °C	Working Pressures by Class, bar						
	150	300	600	900	1500	2500	4500
-29 to 38	17.0	44.3	88.6	133.0	221.6	369.4	664.9
50	17.0	44.3	88.6	132.9	221.5	369.2	664.6
100	16.9	44.1	88.2	132.3	220.5	367.5	661.5
150	16.5	43.0	86.0	129.0	215.0	358.3	644.9
200	16.5	43.0	86.0	129.0	215.0	358.3	644.9
250	16.5	43.0	86.0	129.0	215.0	358.3	644.9
300	16.5	43.0	86.0	129.0	215.0	358.3	644.9
325	16.5	43.0	86.0	129.0	215.0	358.3	644.9
350	16.5	43.0	86.0	129.0	215.0	358.3	644.9
375	16.5	43.0	86.0	129.0	215.0	358.3	644.9
400	16.5	43.0	86.0	129.0	215.0	358.3	644.9
425	16.5	43.0	86.0	129.0	215.0	358.3	644.9
450	16.5	43.0	86.0	129.0	215.0	358.3	644.9
475	15.7	40.9	81.8	122.7	204.6	341.0	613.7
500	12.3	32.1	64.1	96.2	160.3	267.1	480.8
538	7.1	18.6	37.2	55.8	93.1	155.1	279.2

**Table 2-1.8 Ratings for Group 1.8 Materials (Cont'd)**

<b>B — Special Class</b>							
<b>Temperature, °C</b>	<b>Working Pressures by Class, bar</b>						
	<b>150</b>	<b>300</b>	<b>600</b>	<b>900</b>	<b>1500</b>	<b>2500</b>	<b>4500</b>
550	6.1	15.9	31.8	47.7	79.4	132.4	238.3
575	4.2	11.0	22.0	33.0	55.0	91.7	165.1
600	2.9	7.6	15.1	22.7	37.8	63.0	113.5
625	1.9	5.0	10.1	15.1	25.1	41.9	75.4
650	1.2	3.3	6.5	9.8	16.3	27.1	48.8

## NOTES:

- (1) Permissible, but not recommended for prolonged use above 595°C.  
(2) Flanged-end valve ratings terminate at 538°C.

**Table 2-1.9 Ratings for Group 1.9 Materials**

A182 Gr. F11 Cl. 2 (1), (2)	A217 Gr. WC6 (1), (3), (4)	A387 Gr. 11 Cl. 2 (2)	A739 Gr. B11 (2)				
<b>A — Standard Class</b>							
Temperature, °C	Working Pressures by Class, bar						
	150	300	600	900	1500	2500	4500
-29 to 38	19.8	51.7	103.4	155.1	258.6	430.9	775.7
50	19.5	51.7	103.4	155.1	258.6	430.9	775.7
100	17.7	51.5	103.0	154.4	257.4	429.0	772.2
150	15.8	49.7	99.5	149.2	248.7	414.5	746.2
200	13.8	48.0	95.9	143.9	239.8	399.6	719.4
250	12.1	46.3	92.7	139.0	231.8	386.2	694.8
300	10.2	42.9	85.7	128.6	214.4	357.1	642.6
325	9.3	41.4	82.6	124.0	206.6	344.3	619.6
350	8.4	40.3	80.4	120.7	201.1	335.3	603.3
375	7.4	38.9	77.6	116.5	194.1	323.2	581.8
400	6.5	36.5	73.3	109.8	183.1	304.9	548.5
425	5.5	35.2	70.0	105.1	175.1	291.6	524.7
450	4.6	33.7	67.7	101.4	169.0	281.8	507.0
475	3.7	31.7	63.4	95.1	158.2	263.9	474.8
500	2.8	25.7	51.5	77.2	128.6	214.4	385.9
538	1.4	14.9	29.8	44.7	74.5	124.1	223.4
550	1.4 (5)	12.7	25.4	38.1	63.5	105.9	190.6
575	1.4 (5)	8.8	17.6	26.4	44.0	73.4	132.0
600	1.4 (5)	6.1	12.2	18.3	30.5	50.9	91.6
625	1.4 (5)	4.3	8.5	12.8	21.3	35.5	63.9
650	1.1 (5)	2.8	5.7	8.5	14.2	23.6	42.6
<b>B — Special Class</b>							
Temperature, °C	Working Pressures by Class, bar						
	150	300	600	900	1500	2500	4500
-29 to 38	19.8	51.7	103.4	155.1	258.6	430.9	775.7
50	19.8	51.7	103.4	155.1	258.6	430.9	775.7
100	19.8	51.7	103.4	155.1	258.6	430.9	775.7
150	19.8	51.7	103.4	155.1	258.6	430.9	775.7
200	19.8	51.7	103.4	155.1	258.6	430.9	775.7
250	19.8	51.7	103.4	155.1	258.6	430.9	775.7
300	19.8	51.7	103.4	155.1	258.6	430.9	775.7
325	19.8	51.7	103.4	155.1	258.6	430.9	775.7
350	19.8	51.5	102.8	154.3	257.1	428.6	771.4
375	19.3	50.6	101.0	151.5	252.5	420.9	757.4
400	19.3	50.3	100.6	150.6	251.2	418.3	753.2
425	19.0	49.6	99.3	148.9	248.2	413.7	744.6
450	18.1	47.3	94.4	141.4	235.8	393.1	707.6
475	16.4	42.8	85.5	128.2	213.7	356.3	641.3
500	12.3	32.2	64.3	96.5	160.8	268.0	482.4
538	7.1	18.6	37.2	55.8	93.1	155.1	279.2

**Table 2-1.9 Ratings for Group 1.9 Materials (Cont'd)**

<b>B — Special Class</b>							
<b>Temperature, °C</b>	<b>Working Pressures by Class, bar</b>						
	<b>150</b>	<b>300</b>	<b>600</b>	<b>900</b>	<b>1500</b>	<b>2500</b>	<b>4500</b>
550	6.1	15.9	31.8	47.7	79.4	132.4	238.3
575	4.2	11.0	22.0	33.0	55.0	91.7	165.1
600	2.9	7.6	15.3	22.9	38.2	63.6	114.5
625	2.0	5.3	10.6	16.0	26.6	44.4	79.9
650	1.4	3.5	7.1	10.6	17.7	29.5	53.2

## NOTES:

- (1) Use normalized and tempered material only.
- (2) Permissible, but not recommended for prolonged use above 595°C.
- (3) Not to be used over 595°C.
- (4) The deliberate addition of any element not listed in ASTM A217, Table 1 is prohibited, except that calcium (Ca) and manganese (Mn) may be added for deoxidation.
- (5) Flanged-end valve ratings terminate at 538°C.

**Table 2-1.10 Ratings for Group 1.10 Materials**

A182 Gr. F22 Cl. 3 (1)	A217 Gr. WC9 (2)-(4)	A387 Gr. 22 Cl. 2 (1)	A739 Gr. B22 (2)				
A — Standard Class							
Temperature, °C	Working Pressures by Class, bar						
	150	300	600	900	1500	2500	4500
-29 to 38	19.8	51.7	103.4	155.1	258.6	430.9	775.7
50	19.5	51.7	103.4	155.1	258.6	430.9	775.7
100	17.7	51.5	103.0	154.6	257.6	429.4	773.0
150	15.8	50.3	100.3	150.6	250.8	418.2	752.8
200	13.8	48.6	97.2	145.8	243.4	405.4	729.8
250	12.1	46.3	92.7	139.0	231.8	386.2	694.8
300	10.2	42.9	85.7	128.6	214.4	357.1	642.6
325	9.3	41.4	82.6	124.0	206.6	344.3	619.6
350	8.4	40.3	80.4	120.7	201.1	335.3	603.3
375	7.4	38.9	77.6	116.5	194.1	323.2	581.8
400	6.5	36.5	73.3	109.8	183.1	304.9	548.5
425	5.5	35.2	70.0	105.1	175.1	291.6	524.7
450	4.6	33.7	67.7	101.4	169.0	281.8	507.0
475	3.7	31.7	63.4	95.1	158.2	263.9	474.8
500	2.8	28.2	56.5	84.7	140.9	235.0	423.0
538	1.4	18.4	36.9	55.3	92.2	153.7	276.6
550	1.4 (5)	15.6	31.3	46.9	78.2	130.3	234.5
575	1.4 (5)	10.5	21.1	31.6	52.6	87.7	157.9
600	1.4 (5)	6.9	13.8	20.7	34.4	57.4	103.3
625	1.4 (5)	4.5	8.9	13.4	22.3	37.2	66.9
650	1.1 (5)	2.8	5.7	8.5	14.2	23.6	42.6
B — Special Class							
Temperature, °C	Working Pressures by Class, bar						
	150	300	600	900	1500	2500	4500
-29 to 38	19.8	51.7	103.4	155.1	258.6	430.9	775.7
50	19.8	51.7	103.4	155.1	258.6	430.9	775.7
100	19.8	51.6	103.2	154.9	258.1	430.2	774.3
150	19.5	51.0	101.9	152.9	254.8	424.6	764.3
200	19.3	50.2	100.4	150.7	251.1	418.5	753.4
250	19.2	50.0	100.0	149.9	249.9	416.5	749.7
300	19.1	49.8	99.6	149.3	248.9	414.8	746.7
325	19.0	49.6	99.2	148.8	248.0	413.3	743.9
350	18.9	49.2	98.4	147.6	246.0	410.0	738.1
375	18.7	48.8	97.5	146.3	243.8	406.3	731.3
400	18.7	48.8	97.5	146.3	243.8	406.3	731.3
425	18.7	48.8	97.5	146.3	243.8	406.3	731.3
450	18.1	47.3	94.4	141.4	235.8	393.1	707.6
475	16.4	42.8	85.5	128.2	213.7	356.3	641.3
500	13.7	35.6	71.5	107.1	178.6	297.5	535.4
538	8.8	23.0	46.1	69.1	115.2	192.1	345.7

**Table 2-1.10 Ratings for Group 1.10 Materials (Cont'd)**

<b>B — Special Class</b>							
<b>Temperature, °C</b>	<b>Working Pressures by Class, bar</b>						
	<b>150</b>	<b>300</b>	<b>600</b>	<b>900</b>	<b>1500</b>	<b>2500</b>	<b>4500</b>
550	7.5	19.5	39.1	58.6	97.7	162.8	293.1
575	5.0	13.2	26.3	39.5	65.8	109.7	197.4
600	3.3	8.6	17.2	25.8	43.0	71.7	129.1
625	2.1	5.6	11.2	16.7	27.9	46.5	83.7
650	1.4	3.5	7.1	10.6	17.7	29.5	53.2

## NOTES:

- (1) Permissible, but not recommended for prolonged use above 595°C.
- (2) Use normalized and tempered material only.
- (3) Not to be used over 595°C.
- (4) The deliberate addition of any element not listed in ASTM A217, Table 1 is prohibited, except that calcium (Ca) and manganese (Mn) may be added for deoxidation.
- (5) Flanged-end valve ratings terminate at 538°C.

**Table 2-1.11 Ratings for Group 1.11 Materials**

A182 Gr. F21 (1)		A302 Gr. B (2)		A302 Gr. D (2)		A537 Cl. 2 (3)		
A204 Gr. C (4)		A302 Gr. C (2)		A387 Gr. 21 Cl. 2 (1)				
A302 Gr. A (2)								
<b>A — Standard Class</b>								
Temperature, °C	Working Pressures by Class, bar							
	150	300	600	900	1500	2500	4500	
-29 to 38	20.0	51.7	103.4	155.1	258.6	430.9	775.7	
50	19.5	51.7	103.4	155.1	258.6	430.9	775.7	
100	17.7	51.5	103.0	154.6	257.6	429.4	773.0	
150	15.8	50.3	100.3	150.6	250.8	418.2	752.8	
200	13.8	48.6	97.2	145.8	243.4	405.4	729.8	
250	12.1	46.3	92.7	139.0	231.8	386.2	694.8	
300	10.2	42.9	85.7	128.6	214.4	357.1	642.6	
325	9.3	41.4	82.6	124.0	206.6	344.3	619.6	
350	8.4	40.3	80.4	120.7	201.1	335.3	603.3	
375	7.4	38.9	77.6	116.5	194.1	323.2	581.8	
400	6.5	36.5	73.3	109.8	183.1	304.9	548.5	
425	5.5	35.2	70.0	105.1	175.1	291.6	524.7	
450	4.6	33.7	67.7	101.4	169.0	281.8	507.0	
475	3.7	31.7	63.4	95.1	158.2	263.9	474.8	
500	2.8	23.6	47.1	70.7	117.8	196.3	353.3	
538	1.4	11.3	22.7	34.0	56.7	94.6	170.2	
550	1.4 (5)	11.3	22.7	34.0	56.7	94.6	170.2	
575	1.4 (5)	10.1	20.1	30.2	50.3	83.8	150.9	
600	1.4 (5)	7.1	14.2	21.3	35.6	59.3	106.7	
625	1.4 (5)	5.3	10.6	15.9	26.5	44.2	79.6	
650	1.2 (5)	3.1	6.1	9.2	15.4	25.6	46.1	
<b>B — Special Class</b>								
Temperature, °C	Working Pressures by Class, bar							
	150	300	600	900	1500	2500	4500	
-29 to 38	20.0	51.7	103.4	155.1	258.6	430.9	775.7	
50	20.0	51.7	103.4	155.1	258.6	430.9	775.7	
100	20.0	51.7	103.4	155.1	258.6	430.9	775.7	
150	20.0	51.7	103.4	155.1	258.6	430.9	775.7	
200	20.0	51.7	103.4	155.1	258.6	430.9	775.7	
250	20.0	51.7	103.4	155.1	258.6	430.9	775.7	
300	20.0	51.7	103.4	155.1	258.6	430.9	775.7	
325	20.0	51.7	103.4	155.1	258.6	430.9	775.7	
350	19.8	51.5	102.8	154.3	257.1	428.6	771.4	
375	19.3	50.6	101.0	151.5	252.5	420.9	757.4	
400	19.3	50.3	100.6	150.6	251.2	418.3	753.2	
425	19.0	49.6	99.3	148.9	248.2	413.7	744.6	
450	18.1	47.3	94.4	141.4	235.8	393.1	707.6	
475	16.1	42.1	84.2	126.3	210.5	350.9	631.6	

**Table 2-1.11 Ratings for Group 1.11 Materials (Cont'd)**

<b>B — Special Class</b>							
<b>Temperature, °C</b>	<b>Working Pressures by Class, bar</b>						
	<b>150</b>	<b>300</b>	<b>600</b>	<b>900</b>	<b>1500</b>	<b>2500</b>	<b>4500</b>
500	11.3	29.4	58.9	88.3	147.2	245.4	441.6
538	5.4	14.2	28.4	42.6	70.9	118.2	212.8
550	5.4	14.2	28.4	42.6	70.9	118.2	212.8
575	4.9	12.8	25.5	38.3	63.9	106.4	191.6
600	3.4	8.9	17.8	26.7	44.4	74.1	133.3
625	2.5	6.6	13.3	19.9	33.2	55.3	99.6
650	1.5	3.8	7.7	11.5	19.2	32.0	57.6

## NOTES:

- (1) Permissible, but not recommended for prolonged use above 595°C.
- (2) Upon prolonged exposure to temperatures above 470°C, the carbide phase of carbon-molybdenum steel may be converted to graphite. Permissible, but not recommended for prolonged use above 470°C.
- (3) Not to be used over 370°C.
- (4) Upon prolonged exposure to temperatures above 470°C, the carbide phase of steel may be converted to graphite. Permissible, but not recommended for prolonged usage above 470°C.
- (5) Flanged-end valve ratings terminate at 538°C.



**Table 2-1.12 Ratings for Group 1.12 Materials**

A335 Gr. P5 A335 Gr. P5b	A369 Gr. FP5 A387 Gr. 5 Cl. 1	A387 Gr. 5 Cl. 2	A691 Gr. 5CR				
<b>A — Standard Class</b>							
Temperature, °C	Working Pressures by Class, bar						
	150	300	600	900	1500	2500	4500
-29 to 38	16.3	42.6	85.1	127.7	212.8	354.6	638.3
50	16.0	41.6	83.3	124.9	208.2	347.0	624.7
100	14.7	38.3	76.5	114.8	191.3	318.9	574.0
150	14.2	37.0	74.0	111.0	185.1	308.4	555.2
200	13.8	36.6	73.3	109.9	183.1	305.2	549.4
250	12.1	36.4	72.7	109.1	181.8	303.0	545.4
300	10.2	35.9	71.8	107.7	179.5	299.2	538.5
325	9.3	35.6	71.2	106.8	178.0	296.6	534.0
350	8.4	35.2	70.4	105.5	175.9	293.2	527.7
375	7.4	34.6	69.3	103.9	173.2	288.6	519.5
400	6.5	33.9	67.7	101.6	169.3	282.1	507.8
425	5.5	32.8	65.7	98.5	164.2	273.6	492.5
450	4.6	31.7	63.4	95.1	158.5	264.1	475.4
475	3.7	27.3	54.5	81.8	136.3	227.1	408.8
500	2.8	21.4	42.8	64.1	106.9	178.2	320.7
538	1.4	13.7	27.4	41.1	68.6	114.3	205.7
550	1.4 (1)	12.0	24.1	36.1	60.2	100.4	180.7
575	1.4 (1)	8.9	17.8	26.7	44.4	74.0	133.3
600	1.4 (1)	6.2	12.5	18.7	31.2	51.9	93.5
625	1.4 (1)	4.0	8.0	12.0	20.0	33.3	59.9
650	0.9 (1)	2.4	4.7	7.1	11.8	19.7	35.5
<b>B — Special Class</b>							
Temperature, °C	Working Pressures by Class, bar						
	150	300	600	900	1500	2500	4500
-29 to 38	17.0	44.3	88.6	133.0	221.6	369.4	664.9
50	17.0	44.3	88.6	132.9	221.5	369.2	664.6
100	16.9	44.1	88.2	132.3	220.5	367.4	661.4
150	16.5	42.9	85.8	128.7	214.6	357.6	643.7
200	16.3	42.6	85.3	127.9	213.2	355.4	639.7
250	16.3	42.5	85.0	127.5	212.5	354.2	637.5
300	16.1	42.1	84.1	126.2	210.3	350.4	630.8
325	16.0	41.7	83.3	125.0	208.3	347.2	624.9
350	15.7	41.0	82.0	123.0	205.0	341.7	615.1
375	15.5	40.3	80.7	121.0	201.7	336.1	605.0
400	15.5	40.3	80.7	121.0	201.7	336.1	605.0
425	15.5	40.3	80.7	121.0	201.7	336.1	605.0
450	15.5	40.3	80.7	121.0	201.7	336.1	605.0
475	13.2	34.3	68.6	103.0	171.6	286.0	514.8

**Table 2-1.12 Ratings for Group 1.12 Materials (Cont'd)**

<b>B — Special Class</b>							
<b>Temperature, °C</b>	<b>Working Pressures by Class, bar</b>						
	<b>150</b>	<b>300</b>	<b>600</b>	<b>900</b>	<b>1500</b>	<b>2500</b>	<b>4500</b>
500	10.2	26.7	53.4	80.2	133.6	222.7	400.9
538	6.6	17.1	34.3	51.4	85.7	142.8	257.1
550	5.8	15.1	30.1	45.2	75.3	125.5	225.9
575	4.3	11.1	22.2	33.3	55.5	92.5	166.6
600	3.0	7.8	15.6	23.4	38.9	64.9	116.8
625	1.9	5.0	10.0	15.0	24.9	41.6	74.8
650	1.1	3.0	5.9	8.9	14.8	24.6	44.3

NOTE: (1) Flanged-end valve ratings terminate at 538°C.

**Table 2-1.13 Ratings for Group 1.13 Materials**

A182 Gr. F5a		A217 Gr. C5 (1), (2)					
A — Standard Class							
Temperature, °C	Working Pressures by Class, bar						
	150	300	600	900	1500	2500	4500
-29 to 38	20.0	51.7	103.4	155.1	258.6	430.9	775.7
50	19.5	51.7	103.4	155.1	258.6	430.9	775.7
100	17.7	51.5	103.0	154.6	257.6	429.4	773.0
150	15.8	50.3	100.3	150.6	250.8	418.2	752.8
200	13.8	48.6	97.2	145.8	243.4	405.4	729.8
250	12.1	46.3	92.7	139.0	231.8	386.2	694.8
300	10.2	42.9	85.7	128.6	214.4	357.1	642.6
325	9.3	41.4	82.6	124.0	206.6	344.3	619.6
350	8.4	40.3	80.4	120.7	201.1	335.3	603.3
375	7.4	38.9	77.6	116.5	194.1	323.2	581.8
400	6.5	36.5	73.3	109.8	183.1	304.9	548.5
425	5.5	35.2	70.0	105.1	175.1	291.6	524.7
450	4.6	33.7	67.7	101.4	169.0	281.8	507.0
475	3.7	27.9	55.7	83.6	139.3	232.1	417.8
500	2.8	21.4	42.8	64.1	106.9	178.2	320.7
538	1.4	13.7	27.4	41.1	68.6	114.3	205.7
550	1.4 (3)	12.0	24.1	36.1	60.2	100.4	180.7
575	1.4 (3)	8.9	17.8	26.7	44.4	74.0	133.3
600	1.4 (3)	6.2	12.5	18.7	31.2	51.9	93.5
625	1.4 (3)	4.0	8.0	12.0	20.0	33.3	59.9
650	0.9 (3)	2.4	4.7	7.1	11.8	19.7	35.5
B — Special Class							
Temperature, °C	Working Pressures by Class, bar						
	150	300	600	900	1500	2500	4500
-29 to 38	20.0	51.7	103.4	155.1	258.6	430.9	775.7
50	20.0	51.7	103.4	155.1	258.6	430.9	775.7
100	20.0	51.7	103.4	155.1	258.6	430.9	775.7
150	20.0	51.7	103.4	155.1	258.6	430.9	775.7
200	20.0	51.7	103.4	155.1	258.6	430.9	775.7
250	20.0	51.7	103.4	155.1	258.6	430.9	775.7
300	20.0	51.7	103.4	155.1	258.6	430.9	775.7
325	20.0	51.7	103.4	155.1	258.6	430.9	775.7
350	19.8	51.5	102.8	154.3	257.1	428.6	771.4
375	19.3	50.6	101.0	151.5	252.5	420.9	757.4
400	19.3	50.3	100.6	150.6	251.2	418.3	753.2
425	19.0	49.6	99.3	148.9	248.2	413.7	744.6
450	18.1	45.2	90.3	135.5	225.9	376.5	677.6
475	16.4	34.8	69.6	104.5	174.1	290.2	522.3
500	13.4	26.7	53.4	80.2	133.6	222.7	400.9
538	8.6	17.1	34.3	51.4	85.7	142.8	257.1

**Table 2-1.13 Ratings for Group 1.13 Materials (Cont'd)**

<b>B — Special Class</b>							
<b>Temperature, °C</b>	<b>Working Pressures by Class, bar</b>						
	<b>150</b>	<b>300</b>	<b>600</b>	<b>900</b>	<b>1500</b>	<b>2500</b>	<b>4500</b>
550	7.5	15.1	30.1	45.2	75.3	125.5	225.9
575	5.6	11.1	22.2	33.3	55.5	92.5	166.6
600	3.9	7.8	15.6	23.4	38.9	64.9	116.8
625	2.5	5.0	10.0	15.0	24.9	41.6	74.8
650	1.5	3.0	5.9	8.9	14.8	24.6	44.3

## NOTES:

- (1) Use normalized and tempered material only.
- (2) The deliberate addition of any element not listed in ASTM A217, Table 1 is prohibited, except that calcium (Ca) and manganese (Mn) may be added for deoxidation.
- (3) Flanged-end valve ratings terminate at 538°C.

**Table 2-1.14 Ratings for Group 1.14 Materials**

A182 Gr. F9		A217 Gr. C12 (1), (2)					
A — Standard Class							
Temperature, °C	Working Pressures by Class, bar						
	150	300	600	900	1500	2500	4500
-29 to 38	20.0	51.7	103.4	155.1	258.6	430.9	775.7
50	19.5	51.7	103.4	155.1	258.6	430.9	775.7
100	17.7	51.5	103.0	154.6	257.6	429.4	773.0
150	15.8	50.3	100.3	150.6	250.8	418.2	752.8
200	13.8	48.6	97.2	145.8	243.4	405.4	729.8
250	12.1	46.3	92.7	139.0	231.8	386.2	694.8
300	10.2	42.9	85.7	128.6	214.4	357.1	642.6
325	9.3	41.4	82.6	124.0	206.6	344.3	619.6
350	8.4	40.3	80.4	120.7	201.1	335.3	603.3
375	7.4	38.9	77.6	116.5	194.1	323.2	581.8
400	6.5	36.5	73.3	109.8	183.1	304.9	548.5
425	5.5	35.2	70.0	105.1	175.1	291.6	524.7
450	4.6	33.7	67.7	101.4	169.0	281.8	507.0
475	3.7	31.7	63.4	95.1	158.2	263.9	474.8
500	2.8	28.2	56.5	84.7	140.9	235.0	423.0
538	1.4	17.5	35.0	52.5	87.5	145.8	262.4
550	1.4 (3)	15.0	30.0	45.0	75.0	125.0	225.0
575	1.4 (3)	10.5	20.9	31.4	52.3	87.1	156.8
600	1.4 (3)	7.2	14.4	21.5	35.9	59.8	107.7
625	1.4 (3)	5.0	9.9	14.9	24.8	41.4	74.5
650	1.4 (3)	3.5	7.1	10.6	17.7	29.5	53.2
B — Special Class							
Temperature, °C	Working Pressures by Class, bar						
	150	300	600	900	1500	2500	4500
-29 to 38	20.0	51.7	103.4	155.1	258.6	430.9	775.7
50	20.0	51.7	103.4	155.1	258.6	430.9	775.7
100	20.0	51.7	103.4	155.1	258.6	430.9	775.7
150	20.0	51.7	103.4	155.1	258.6	430.9	775.7
200	20.0	51.7	103.4	155.1	258.6	430.9	775.7
250	20.0	51.7	103.4	155.1	258.6	430.9	775.7
300	20.0	51.7	103.4	155.1	258.6	430.9	775.7
325	20.0	51.7	103.4	155.1	258.6	430.9	775.7
350	19.8	51.5	102.8	154.3	257.1	428.6	771.4
375	19.3	50.6	101.0	151.5	252.5	420.9	757.4
400	19.3	50.3	100.6	150.6	251.2	418.3	753.2
425	19.0	49.6	99.3	148.9	248.2	413.7	744.6
450	18.1	47.3	94.4	141.4	235.8	393.1	707.6
475	16.4	42.8	85.5	128.2	213.7	356.3	641.3
500	13.7	35.6	71.5	107.1	178.6	297.5	535.4
538	8.4	21.9	43.7	65.6	109.3	182.2	328.0

**Table 2-1.14 Ratings for Group 1.14 Materials (Cont'd)**

<b>B — Special Class</b>							
<b>Temperature, °C</b>	<b>Working Pressures by Class, bar</b>						
	<b>150</b>	<b>300</b>	<b>600</b>	<b>900</b>	<b>1500</b>	<b>2500</b>	<b>4500</b>
550	7.2	18.7	37.5	56.2	93.7	156.2	281.2
575	5.0	13.1	26.1	39.2	65.3	108.9	196.0
600	3.4	9.0	17.9	26.9	44.9	74.8	134.6
625	2.4	6.2	12.4	18.6	31.1	51.8	93.2
650	1.7	4.4	8.9	13.3	22.2	36.9	66.5

## NOTES:

- (1) Use normalized and tempered material only.
- (2) The deliberate addition of any element not listed in ASTM A217, Table 1 is prohibited, except that calcium (Ca) and manganese (Mn) may be added for deoxidation.
- (3) Flanged-end valve ratings terminate at 538°C.

**Table 2-1.15 Ratings for Group 1.15 Materials**

A182 Gr. F91	A217 Gr. C12A (1)	A335 Gr. P91	A387 Gr. 91 Cl. 2				
A — Standard Class							
Temperature, °C	Working Pressures by Class, bar						
	150	300	600	900	1500	2500	4500
-29 to 38	20.0	51.7	103.4	155.1	258.6	430.9	775.7
50	19.5	51.7	103.4	155.1	258.6	430.9	775.7
100	17.7	51.5	103.0	154.6	257.6	429.4	773.0
150	15.8	50.3	100.3	150.6	250.8	418.2	752.8
200	13.8	48.6	97.2	145.8	243.4	405.4	729.8
250	12.1	46.3	92.7	139.0	231.8	386.2	694.8
300	10.2	42.9	85.7	128.6	214.4	357.1	642.6
325	9.3	41.4	82.6	124.0	206.6	344.3	619.6
350	8.4	40.3	80.4	120.7	201.1	335.3	603.3
375	7.4	38.9	77.6	116.5	194.1	323.2	581.8
400	6.5	36.5	73.3	109.8	183.1	304.9	548.5
425	5.5	35.2	70.0	105.1	175.1	291.6	524.7
450	4.6	33.7	67.7	101.4	169.0	281.8	507.0
475	3.7	31.7	63.4	95.1	158.2	263.9	474.8
500	2.8	28.2	56.5	84.7	140.9	235.0	423.0
538	1.4	25.2	50.0	75.2	125.5	208.9	375.8
550	1.4 (2)	25.0	49.8	74.8	124.9	208.0	374.2
575	1.4 (2)	24.0	47.9	71.8	119.7	199.5	359.1
600	1.4 (2)	19.5	39.0	58.5	97.5	162.5	292.5
625	1.4 (2)	14.6	29.2	43.8	73.0	121.7	219.1
650	1.4 (2)	9.9	19.9	29.8	49.6	82.7	148.9
B — Special Class							
Temperature, °C	Working Pressures by Class, bar						
	150	300	600	900	1500	2500	4500
-29 to 38	20.0	51.7	103.4	155.1	258.6	430.9	775.7
50	20.0	51.7	103.4	155.1	258.6	430.9	775.7
100	20.0	51.7	103.4	155.1	258.6	430.9	775.7
150	20.0	51.7	103.4	155.1	258.6	430.9	775.7
200	20.0	51.7	103.4	155.1	258.6	430.9	775.7
250	20.0	51.7	103.4	155.1	258.6	430.9	775.7
300	20.0	51.7	103.4	155.1	258.6	430.9	775.7
325	20.0	51.7	103.4	155.1	258.6	430.9	775.7
350	19.8	51.5	102.8	154.3	257.1	428.6	771.4
375	19.3	50.6	101.0	151.5	252.5	420.9	757.4
400	19.3	50.3	100.6	150.6	251.2	418.3	753.2
425	19.0	49.6	99.3	148.9	248.2	413.7	744.6
450	18.1	47.3	94.4	141.4	235.8	393.1	707.6
475	16.4	42.8	85.5	128.2	213.7	356.3	641.3
500	13.7	35.6	71.5	107.1	178.6	297.5	535.4
538	11.0	29.0	57.9	86.9	145.1	241.7	435.1

**Table 2-1.15 Ratings for Group 1.15 Materials (Cont'd)**

<b>B — Special Class</b>							
<b>Temperature, °C</b>	<b>Working Pressures by Class, bar</b>						
	<b>150</b>	<b>300</b>	<b>600</b>	<b>900</b>	<b>1500</b>	<b>2500</b>	<b>4500</b>
550	11.0	29.0	57.9	86.9	145.1	241.7	435.1
575	10.9	28.6	57.1	85.7	143.0	238.3	428.8
600	9.3	24.4	48.7	73.1	121.9	203.1	365.6
625	7.0	18.3	36.5	54.8	91.3	152.1	273.8
650	4.8	12.4	24.8	37.2	62.1	103.4	186.2

## NOTES:

- (1) The deliberate addition of any element not listed in ASTM A217, Table 1 is prohibited, except that calcium (Ca) and manganese (Mn) may be added for deoxidation.
- (2) Flanged-end valve ratings terminate at 538°C.



**Table 2-1.16 Ratings for Group 1.16 Materials**

A335 Gr. P1 (1), (2)		A335 Gr. P12 (3)		A369 Gr. FP11 (3)		A387 Gr. 12 Cl. 1 (3)	
A335 Gr. P11 (3)		A369 Gr. FP1 (1), (2)		A369 Gr. FP12 (3)		A691 Gr. 1CR (3), (4)	
<b>A — Standard Class</b>							
Temperature, °C	Working Pressures by Class, bar						
	150	300	600	900	1500	2500	4500
-29 to 38	15.6	40.6	81.3	121.9	203.1	338.6	609.4
50	15.5	40.3	80.7	121.0	201.7	336.1	605.0
100	15.0	39.1	78.1	117.2	195.3	325.4	585.8
150	14.3	37.3	74.5	111.8	186.4	310.6	559.1
200	13.8	36.0	72.0	108.0	180.0	300.0	540.0
250	12.1	34.8	69.7	104.5	174.2	290.3	522.6
300	10.2	33.7	67.4	101.1	168.4	280.7	505.3
325	9.3	33.1	66.3	99.4	165.7	276.2	497.1
350	8.4	32.6	65.2	97.8	163.0	271.6	488.9
375	7.4	32.0	64.0	95.9	159.9	266.5	479.6
400	6.5	31.5	62.9	94.4	157.3	262.1	471.8
425	5.5	30.7	61.4	92.1	153.4	255.7	460.3
450	4.6	29.9	59.8	89.8	149.6	249.3	448.8
475	3.7	29.2	58.3	87.5	145.8	243.0	437.3
500	2.8	22.8	45.6	68.5	114.1	190.2	342.3
538	1.4	11.3	22.7	34.0	56.7	94.6	170.2
550	1.4 (5)	10.7	21.4	32.2	53.6	89.4	160.8
575	1.4 (5)	8.8	17.6	26.4	44.0	73.4	132.0
600	1.4 (5)	6.1	12.1	18.2	30.3	50.4	90.8
625	1.4 (5)	4.0	8.0	12.1	20.1	33.5	60.4
650	1.0 (5)	2.6	5.2	7.8	13.0	21.7	39.0
<b>B — Special Class</b>							
Temperature, °C	Working Pressures by Class, bar						
	150	300	600	900	1500	2500	4500
-29 to 38	15.6	40.6	81.3	121.9	203.1	338.6	609.4
50	15.5	40.5	80.9	121.4	202.3	337.2	607.0
100	15.3	39.8	79.6	119.4	199.0	331.6	596.9
150	15.0	39.1	78.2	117.2	195.4	325.7	586.2
200	15.0	39.1	78.2	117.2	195.4	325.7	586.2
250	15.0	39.1	78.2	117.2	195.4	325.7	586.2
300	15.0	39.1	78.2	117.2	195.4	325.7	586.2
325	15.0	39.1	78.2	117.2	195.4	325.7	586.2
350	15.0	39.1	78.2	117.2	195.4	325.7	586.2
375	15.0	39.1	78.2	117.2	195.4	325.7	586.2
400	15.0	39.1	78.2	117.2	195.4	325.7	586.2
425	15.0	39.1	78.2	117.2	195.4	325.7	586.2
450	15.0	39.1	78.2	117.2	195.4	325.7	586.2
475	14.8	38.7	77.4	116.2	193.6	322.7	580.8
500	11.3	29.4	58.8	88.2	147.0	245.0	441.0

**Table 2-1.16 Ratings for Group 1.16 Materials (Cont'd)**

<b>B — Special Class</b>							
<b>Temperature, °C</b>	<b>Working Pressures by Class, bar</b>						
	<b>150</b>	<b>300</b>	<b>600</b>	<b>900</b>	<b>1500</b>	<b>2500</b>	<b>4500</b>
538	5.4	14.2	28.4	42.6	70.9	118.2	212.8
550	5.3	13.8	27.6	41.4	69.0	114.9	206.9
575	4.4	11.6	23.2	34.8	57.9	96.6	173.8
600	2.9	7.6	15.1	22.7	37.8	63.0	113.5
625	1.9	5.0	10.1	15.1	25.1	41.9	75.4
650	1.2	3.3	6.5	9.8	16.3	27.1	48.8

## NOTES:

- (1) Upon prolonged exposure to temperatures above 470°C, the carbide phase of steel may be converted to graphite. Permissible, but not recommended for prolonged usage above 470°C.
- (2) Not to be used over 538°C.
- (3) Permissible, but not recommended for prolonged use above 595°C.
- (4) Use normalized and tempered material only.
- (5) Flanged-end valve ratings terminate at 538°C.

**Table 2-1.17 Ratings for Group 1.17 Materials**

A182 Gr. F12 Cl. 2 (1), (2)		A182 Gr. F5					
A — Standard Class							
Temperature, °C	Working Pressures by Class, bar						
	150	300	600	900	1500	2500	4500
-29 to 38	19.8	51.7	103.4	155.1	258.6	430.9	775.7
50	19.5	51.5	103.0	154.5	257.5	429.2	772.5
100	17.7	50.4	100.9	151.3	252.2	420.4	756.7
150	15.8	48.2	96.4	144.5	240.9	401.5	722.7
200	13.8	46.3	92.5	138.8	231.3	385.6	694.0
250	12.1	44.8	89.6	134.5	224.1	373.5	672.3
300	10.2	42.9	85.7	128.6	214.4	357.1	642.6
325	9.3	41.4	82.6	124.0	206.6	344.3	619.6
350	8.4	40.3	80.4	120.7	201.1	335.3	603.3
375	7.4	38.9	77.6	116.5	194.1	323.2	581.8
400	6.5	36.5	73.3	109.8	183.1	304.9	548.5
425	5.5	35.2	70.0	105.1	175.1	291.6	524.7
450	4.6	33.7	67.7	101.4	169.0	281.8	507.0
475	3.7	27.9	55.7	83.6	139.3	232.1	417.8
500	2.8	21.4	42.8	64.1	106.9	178.2	320.7
538	1.4	13.7	27.4	41.1	68.6	114.3	205.7
550	1.4 (3)	12.0	24.1	36.1	60.2	100.4	180.7
575	1.4 (3)	8.8	17.6	26.4	44.0	73.4	132.0
600	1.4 (3)	6.1	12.1	18.2	30.3	50.4	90.8
625	1.4 (3)	4.0	8.0	12.0	20.0	33.3	59.9
650	0.9 (3)	2.4	4.7	7.1	11.8	19.7	35.5
B — Special Class							
Temperature, °C	Working Pressures by Class, bar						
	150	300	600	900	1500	2500	4500
-29 to 38	19.8	51.7	103.4	155.1	258.6	430.9	775.7
50	19.7	51.5	103.0	154.5	257.5	429.2	772.5
100	19.4	50.6	101.3	151.9	253.1	421.9	759.4
150	19.1	49.7	99.4	149.1	248.6	414.3	745.7
200	19.1	49.7	99.4	149.1	248.6	414.3	745.7
250	19.0	49.6	99.2	148.8	248.0	413.3	743.9
300	18.8	49.0	98.1	147.1	245.2	408.6	735.5
325	18.6	48.6	97.2	145.7	242.9	404.8	728.7
350	18.3	47.8	95.7	143.5	239.2	398.7	717.6
375	18.0	47.1	94.1	141.2	235.3	392.1	705.9
400	18.0	47.1	94.1	141.2	235.3	392.1	705.9
425	18.0	47.1	94.1	141.2	235.3	392.1	705.9
450	16.5	43.0	86.0	129.1	215.1	358.5	645.3
475	13.3	34.8	69.6	104.5	174.1	290.2	522.3
500	10.2	26.7	53.4	80.2	133.6	222.7	400.9
538	6.6	17.1	34.3	51.4	85.7	142.8	257.1

**Table 2-1.17 Ratings for Group 1.17 Materials (Cont'd)**

<b>B — Special Class</b>							
<b>Temperature, °C</b>	<b>Working Pressures by Class, bar</b>						
	<b>150</b>	<b>300</b>	<b>600</b>	<b>900</b>	<b>1500</b>	<b>2500</b>	<b>4500</b>
550	5.8	15.1	30.1	45.2	75.3	125.5	225.9
575	4.2	11.0	22.0	33.0	55.0	91.7	165.1
600	2.9	7.6	15.1	22.7	37.8	63.0	113.5
625	1.9	5.0	10.0	15.0	24.9	41.6	74.8
650	1.1	3.0	5.9	8.9	14.8	24.6	44.3

## NOTES:

- (1) Use normalized and tempered material only.
- (2) Permissible, but not recommended for prolonged use above 595°C.
- (3) Flanged-end valve ratings terminate at 538°C.

**Table 2-1.18 Ratings for Group 1.18 Materials**

A182 Gr. F92 (1)	A335 Gr. P92 (1)		A369 Gr. FP92 (1)				
<b>A — Standard Class</b>							
Temperature, °C	Working Pressures by Class, bar						
	150	300	600	900	1500	2500	4500
-29 to 38	20.0	51.7	103.4	155.1	258.6	430.9	775.7
50	19.5	51.7	103.4	155.1	258.6	430.9	775.7
100	17.7	51.5	103.0	154.6	257.6	429.4	773.0
150	15.8	50.3	100.3	150.6	250.8	418.2	752.8
200	13.8	48.6	97.2	145.8	243.4	405.4	729.8
250	12.1	46.3	92.7	139.0	231.8	386.2	694.8
300	10.2	42.9	85.7	128.6	214.4	357.1	642.6
325	9.3	41.4	82.6	124.0	206.6	344.3	619.6
350	8.4	40.3	80.4	120.7	201.1	335.3	603.3
375	7.4	38.9	77.6	116.5	194.1	323.2	581.8
400	6.5	36.5	73.3	109.8	183.1	304.9	548.5
425	5.5	35.2	70.0	105.1	175.1	291.6	524.7
450	4.6	33.7	67.7	101.4	169.0	281.8	507.0
475	3.7	31.7	63.4	95.1	158.2	263.9	474.8
500	2.8	28.2	56.5	84.7	140.9	235.0	423.0
538	1.4	25.2	50.0	75.2	125.5	208.9	375.8
550	1.4 (2)	25.0	49.8	74.8	124.9	208.0	374.2
575	1.4 (2)	24.0	47.9	71.8	119.7	199.5	359.1
600	1.4 (2)	21.6	42.9	64.2	107.0	178.5	321.4
625	1.4 (2)	18.3	36.6	54.9	91.2	152.0	273.8
650	1.4 (2)	13.2	26.5	39.7	66.2	110.3	198.6
<b>B — Special Class</b>							
Temperature, °C	Working Pressures by Class, bar						
	150	300	600	900	1500	2500	4500
-29 to 38	20.0	51.7	103.4	155.1	258.6	430.9	775.7
50	20.0	51.7	103.4	155.1	258.6	430.9	775.7
100	20.0	51.7	103.4	155.1	258.6	430.9	775.7
150	20.0	51.7	103.4	155.1	258.6	430.9	775.7
200	20.0	51.7	103.4	155.1	258.6	430.9	775.7
250	20.0	51.7	103.4	155.1	258.6	430.9	775.7
300	20.0	51.7	103.4	155.1	258.6	430.9	775.7
325	20.0	51.7	103.4	155.1	258.6	430.9	775.7
350	19.8	51.5	102.8	154.3	257.1	428.6	771.4
375	19.3	50.6	101.0	151.5	252.5	420.9	757.4
400	19.3	50.3	100.6	150.6	251.2	418.3	753.2
425	19.0	49.6	99.3	148.9	248.2	413.7	744.6
450	18.1	47.3	94.4	141.4	235.8	393.1	707.6
475	16.4	42.8	85.5	128.2	213.7	356.3	641.3
500	13.7	35.6	71.5	107.1	178.6	297.5	535.4
538	11.0	29.0	57.9	86.9	145.1	241.7	435.1

**Table 2-1.18 Ratings for Group 1.18 Materials (Cont'd)**

<b>B — Special Class</b>							
<b>Temperature, °C</b>	<b>Working Pressures by Class, bar</b>						
	<b>150</b>	<b>300</b>	<b>600</b>	<b>900</b>	<b>1500</b>	<b>2500</b>	<b>4500</b>
550	11.0	29.0	57.9	86.9	145.1	241.7	435.1
575	10.9	28.6	57.1	85.7	143.0	238.3	428.8
600	10.3	26.9	53.5	80.4	134.0	223.4	401.9
625	8.7	23.0	45.7	68.6	114.3	190.6	342.8
650	6.3	16.5	33.1	49.6	82.7	137.9	248.2

## NOTES:

- (1) Application above 620°C is limited to tubing of maximum outside diameter of 88.9 mm.  
(2) For welding-end valves only. Flanged-end valve ratings terminate at 538°C.

Table 2-2.1 Ratings for Group 2.1 Materials

A182 Gr. F304 (1)	A312 Gr. TP304 (1)	A351 Gr. CF8 (1)	A430 Gr. FP304 (1)
A182 Gr. F304H	A312 Gr. TP304H	A358 Gr. 304 (1)	A430 Gr. FP304H
A240 Gr. 304 (1)	A351 Gr. CF10	A376 Gr. TP304 (1)	A479 Gr. 304 (1)
A240 Gr. 304H	A351 Gr. CF3 (2)	A376 Gr. TP304H	A479 Gr. 304H

## A — Standard Class

Temperature, °C	Working Pressures by Class, bar						
	150	300	600	900	1500	2500	4500
-29 to 38	19.0	49.6	99.3	148.9	248.2	413.7	744.6
50	18.3	47.8	95.6	143.5	239.1	398.5	717.3
100	15.7	40.9	81.7	122.6	204.3	340.4	612.8
150	14.2	37.0	74.0	111.0	185.0	308.4	555.1
200	13.2	34.5	69.0	103.4	172.4	287.3	517.2
250	12.1	32.5	65.0	97.5	162.4	270.7	487.3
300	10.2	30.9	61.8	92.7	154.6	257.6	463.7
325	9.3	30.2	60.4	90.7	151.1	251.9	453.3
350	8.4	29.6	59.3	88.9	148.1	246.9	444.4
375	7.4	29.0	58.1	87.1	145.2	241.9	435.5
400	6.5	28.4	56.9	85.3	142.2	237.0	426.6
425	5.5	28.0	56.0	84.0	140.0	233.3	419.9
450	4.6	27.4	54.8	82.2	137.0	228.4	411.1
475	3.7	26.9	53.9	80.8	134.7	224.5	404.0
500	2.8	26.5	53.0	79.5	132.4	220.7	397.3
538	1.4	24.4	48.9	73.3	122.1	203.6	366.4
550	1.4 (3)	23.6	47.1	70.7	117.8	196.3	353.4
575	1.4 (3)	20.8	41.7	62.5	104.2	173.7	312.7
600	1.4 (3)	16.9	33.8	50.6	84.4	140.7	253.2
625	1.4 (3)	13.8	27.6	41.4	68.9	114.9	206.8
650	1.4 (3)	11.3	22.5	33.8	56.3	93.8	168.9
675	1.4 (3)	9.3	18.7	28.0	46.7	77.9	140.2
700	1.4 (3)	8.0	16.1	24.1	40.1	66.9	120.4
725	1.4 (3)	6.8	13.5	20.3	33.8	56.3	101.3
750	1.4 (3)	5.8	11.6	17.3	28.9	48.1	86.7
775	1.4 (3)	4.6	9.0	13.7	22.8	38.0	68.4
800	1.2 (3)	3.5	7.0	10.5	17.4	29.2	52.6
816	1.0 (3)	2.8	5.9	8.6	14.1	23.8	42.7

## B — Special Class

Temperature, °C	Working Pressures by Class, bar						
	150	300	600	900	1500	2500	4500
-29 to 38	19.8	51.7	103.4	155.1	258.6	430.9	775.7
50	19.4	50.5	101.0	151.5	252.5	420.8	757.4
100	17.5	45.6	91.2	136.8	228.0	380.0	683.9
150	15.8	41.3	82.6	123.9	206.5	344.2	619.6
200	14.8	38.5	77.0	115.4	192.4	320.7	577.2
250	13.9	36.3	72.5	108.8	181.3	302.2	543.9

**Table 2-2.1 Ratings for Group 2.1 Materials (Cont'd)**

<b>B — Special Class</b>							
<b>Temperature, °C</b>	<b>Working Pressures by Class, bar</b>						
	<b>150</b>	<b>300</b>	<b>600</b>	<b>900</b>	<b>1500</b>	<b>2500</b>	<b>4500</b>
300	13.2	34.5	69.0	103.5	172.5	287.5	517.5
325	12.9	33.7	67.5	101.2	168.7	281.1	506.0
350	12.7	33.1	66.1	99.2	165.3	275.5	496.0
375	12.4	32.4	64.8	97.2	162.0	270.0	486.0
400	12.2	31.7	63.5	95.2	158.7	264.5	476.1
425	12.0	31.2	62.5	93.7	156.2	260.4	468.7
450	11.7	30.6	61.2	91.8	153.0	254.9	458.9
475	11.5	30.1	60.1	90.2	150.3	250.5	450.9
500	11.3	29.6	59.1	88.7	147.8	246.4	443.5
538	11.0	28.6	57.3	85.9	143.1	238.5	429.4
550	10.9	28.4	56.8	85.1	141.9	236.5	425.7
575	10.0	26.1	52.1	78.2	130.3	217.2	390.9
600	8.1	21.1	42.2	63.3	105.5	175.8	316.5
625	6.6	17.2	34.5	51.7	86.2	143.6	258.5
650	5.4	14.1	28.2	42.2	70.4	117.3	211.2
675	4.5	11.7	23.4	35.1	58.4	97.4	175.3
700	4.1	10.7	21.3	32.0	53.3	88.9	160.0
725	3.5	9.2	18.5	27.7	46.2	77.0	138.6
750	2.8	7.4	14.8	22.1	36.7	61.2	110.3
775	2.2	5.8	11.4	17.2	28.5	47.6	85.6
800	1.8	4.4	8.8	13.2	22.0	36.6	65.6
816	1.4	3.4	7.2	10.7	17.9	29.6	53.1

## NOTES:

(1) At temperatures above 538°C, use only when the carbon content is 0.04% or higher.

(2) Not to be used over 425°C.

(3) Flanged-end valve ratings terminate at 538°C.



**Table 2-2.2 Ratings for Group 2.2 Materials**

A182 Gr. F316 (1)	A312 Gr. TP316 (1)	A351 Gr. CF8M (1)	A376 Gr. TP316H
A182 Gr. F316H	A312 Gr. TP316H	A351 Gr. CF10M	A430 Gr. FP316 (1)
A182 Gr. F317 (1)	A312 Gr. TP317 (1)	A351 Gr. CG3M (3)	A430 Gr. FP316H
A240 Gr. 316 (1)	A351 Gr. CF3A (2)	A351 Gr. CG8M (4)	A479 Gr. 316 (1)
A240 Gr. 316H	A351 Gr. CF3M (3)	A358 Gr. 316 (1)	A479 Gr. 316H
A240 Gr. 317 (1)	A351 Gr. CF8A (2)	A376 Gr. TP316 (1)	

**A — Standard Class**

Temperature, °C	Working Pressures by Class, bar						
	150	300	600	900	1500	2500	4500
-29 to 38	19.0	49.6	99.3	148.9	248.2	413.7	744.6
50	18.4	48.1	96.2	144.3	240.6	400.9	721.7
100	16.2	42.2	84.4	126.6	211.0	351.6	632.9
150	14.8	38.5	77.0	115.5	192.5	320.8	577.4
200	13.7	35.7	71.3	107.0	178.3	297.2	534.9
250	12.1	33.4	66.8	100.1	166.9	278.1	500.6
300	10.2	31.6	63.2	94.9	158.1	263.5	474.3
325	9.3	30.9	61.8	92.7	154.4	257.4	463.3
350	8.4	30.3	60.7	91.0	151.6	252.7	454.9
375	7.4	29.9	59.8	89.6	149.4	249.0	448.2
400	6.5	29.4	58.9	88.3	147.2	245.3	441.6
425	5.5	29.1	58.3	87.4	145.7	242.9	437.1
450	4.6	28.8	57.7	86.5	144.2	240.4	432.7
475	3.7	28.7	57.3	86.0	143.4	238.9	430.1
500	2.8	28.2	56.5	84.7	140.9	235.0	423.0
538	1.4	25.2	50.0	75.2	125.5	208.9	375.8
550	1.4 (5)	25.0	49.8	74.8	124.9	208.0	374.2
575	1.4 (5)	24.0	47.9	71.8	119.7	199.5	359.1
600	1.4 (5)	19.9	39.8	59.7	99.5	165.9	298.6
625	1.4 (5)	15.8	31.6	47.4	79.1	131.8	237.2
650	1.4 (5)	12.7	25.3	38.0	63.3	105.5	189.9
675	1.4 (5)	10.3	20.6	31.0	51.6	86.0	154.8
700	1.4 (5)	8.4	16.8	25.1	41.9	69.8	125.7
725	1.4 (5)	7.0	14.0	21.0	34.9	58.2	104.8
750	1.4 (5)	5.9	11.7	17.6	29.3	48.9	87.9
775	1.4 (5)	4.6	9.0	13.7	22.8	38.0	68.4
800	1.2 (5)	3.5	7.0	10.5	17.4	29.2	52.6
816	1.0 (5)	2.8	5.9	8.6	14.1	23.8	42.7

**B — Special Class**

Temperature, °C	Working Pressures by Class, bar						
	150	300	600	900	1500	2500	4500
-29 to 38	19.8	51.7	103.4	155.1	258.6	430.9	775.7
50	19.5	50.8	101.6	152.5	254.1	423.5	762.3
100	18.1	47.1	94.2	141.3	235.5	392.4	706.4
150	16.5	43.0	85.9	128.9	214.8	358.0	644.4

**Table 2-2.2 Ratings for Group 2.2 Materials (Cont'd)**

<b>B — Special Class</b>							
<b>Temperature, °C</b>	<b>Working Pressures by Class, bar</b>						
	<b>150</b>	<b>300</b>	<b>600</b>	<b>900</b>	<b>1500</b>	<b>2500</b>	<b>4500</b>
200	15.3	39.8	79.6	119.4	199.0	331.7	597.0
250	14.3	37.3	74.5	111.8	186.3	310.4	558.8
300	13.5	35.3	70.6	105.9	176.4	294.1	529.3
325	13.2	34.5	68.9	103.4	172.3	287.2	517.0
350	13.0	33.8	67.7	101.5	169.2	282.1	507.7
375	12.8	33.3	66.7	100.0	166.7	277.9	500.2
400	12.6	32.9	65.7	98.6	164.3	273.8	492.9
425	12.5	32.5	65.1	97.6	162.6	271.1	487.9
450	12.3	32.2	64.4	96.6	161.0	268.3	482.9
475	12.3	32.0	64.0	96.0	160.0	266.6	480.0
500	12.2	31.7	63.4	95.1	158.6	264.3	475.7
538	11.0	29.0	57.9	86.9	145.1	241.7	435.1
550	11.0	29.0	57.9	86.9	145.1	241.7	435.1
575	10.9	28.6	57.1	85.7	143.0	238.3	428.8
600	9.5	24.9	49.8	74.6	124.4	207.3	373.2
625	7.6	19.8	39.5	59.3	98.8	164.7	296.5
650	6.1	15.8	31.7	47.5	79.1	131.9	237.4
675	4.9	12.9	25.8	38.7	64.5	107.5	193.5
700	4.4	11.4	22.8	34.3	57.1	95.2	171.3
725	3.7	9.5	19.1	28.6	47.7	79.5	143.0
750	2.8	7.4	14.8	22.1	36.7	61.2	110.3
775	2.2	5.8	11.4	17.2	28.5	47.6	85.6
800	1.8	4.4	8.8	13.2	22.0	36.6	65.6
816	1.4	3.4	7.2	10.7	17.9	29.6	53.1

## NOTES:

- (1) At temperatures above 538°C, use only when the carbon content is 0.04% or higher.
- (2) Not to be used over 345°C.
- (3) Not to be used over 455°C.
- (4) Not to be used over 538°C.
- (5) Flanged-end valve ratings terminate at 538°C.

**Table 2-2.3 Ratings for Group 2.3 Materials**

A182 Gr. F304L (1)	A240 Gr. 304L (1)	A312 Gr. TP316L					
A182 Gr. F316L	A240 Gr. 316L	A479 Gr. 304L (1)					
A182 Gr. F317L	A312 Gr. TP304L (1)	A479 Gr. 316L					
<b>A — Standard Class</b>							
Temperature, °C	Working Pressures by Class, bar						
	150	300	600	900	1500	2500	4500
-29 to 38	15.9	41.4	82.7	124.1	206.8	344.7	620.5
50	15.3	40.0	80.0	120.1	200.1	333.5	600.3
100	13.3	34.8	69.6	104.4	173.9	289.9	521.8
150	12.0	31.4	62.8	94.2	157.0	261.6	470.9
200	11.2	29.2	58.3	87.5	145.8	243.0	437.3
250	10.5	27.5	54.9	82.4	137.3	228.9	412.0
300	10.0	26.1	52.1	78.2	130.3	217.2	391.0
325	9.3	25.5	51.0	76.4	127.4	212.3	382.2
350	8.4	25.1	50.1	75.2	125.4	208.9	376.1
375	7.4	24.8	49.5	74.3	123.8	206.3	371.3
400	6.5	24.3	48.6	72.9	121.5	202.5	364.6
425	5.5	23.9	47.7	71.6	119.3	198.8	357.9
450	4.6	23.4	46.8	70.2	117.1	195.1	351.2
<b>B — Special Class</b>							
Temperature, °C	Working Pressures by Class, bar						
	150	300	600	900	1500	2500	4500
-29 to 38	17.7	46.2	92.3	138.5	230.9	384.8	692.6
50	17.1	44.7	89.3	134.0	223.3	372.2	670.0
100	14.9	38.8	77.7	116.5	194.1	323.6	582.4
150	13.4	35.0	70.1	105.1	175.2	291.9	525.5
200	12.5	32.5	65.1	97.6	162.7	271.2	488.1
250	11.8	30.7	61.3	92.0	153.3	255.4	459.8
300	11.2	29.1	58.2	87.3	145.5	242.4	436.4
325	10.9	28.4	56.9	85.3	142.2	237.0	426.6
350	10.7	28.0	56.0	83.9	139.9	233.2	419.7
375	10.6	27.6	55.2	82.9	138.1	230.2	414.4
400	10.4	27.1	54.3	81.4	135.6	226.0	406.9
425	10.2	26.6	53.3	79.9	133.1	221.9	399.4
450	10.0	26.1	52.3	78.4	130.6	217.7	391.9

NOTE: (1) Not to be used over 425°C.

**Table 2-2.4 Ratings for Group 2.4 Materials**

A182 Gr. F321 (1)	A312 Gr. TP321 (1)	A376 Gr. TP321 (1)	A430 Gr. FP321H				
A182 Gr. F321H (2)	A312 Gr. TP321H	A376 Gr. TP321H	A479 Gr. 321 (1)				
A240 Gr. 321 (1)	A358 Gr. 321 (1)	A430 Gr. FP321 (1)	A479 Gr. 321H				
A240 Gr. 321H (2)							
<b>A — Standard Class</b>							
Temperature, °C	Working Pressures by Class, bar						
	150	300	600	900	1500	2500	4500
-29 to 38	19.0	49.6	99.3	148.9	248.2	413.7	744.6
50	18.6	48.6	97.1	145.7	242.8	404.6	728.3
100	17.0	44.2	88.5	132.7	221.2	368.7	663.6
150	15.7	41.0	82.0	122.9	204.9	341.5	614.7
200	13.8	38.3	76.6	114.9	191.5	319.1	574.5
250	12.1	36.0	72.0	108.1	180.1	300.2	540.4
300	10.2	34.1	68.3	102.4	170.7	284.6	512.2
325	9.3	33.3	66.6	99.9	166.5	277.6	499.6
350	8.4	32.6	65.2	97.8	163.0	271.7	489.1
375	7.4	32.0	64.1	96.1	160.2	266.9	480.5
400	6.5	31.6	63.2	94.8	157.9	263.2	473.8
425	5.5	31.1	62.3	93.4	155.7	259.5	467.1
450	4.6	30.8	61.7	92.5	154.2	256.9	462.5
475	3.7	30.5	61.1	91.6	152.7	254.4	458.0
500	2.8	28.2	56.5	84.7	140.9	235.0	423.0
538	1.4	25.2	50.0	75.2	125.5	208.9	375.8
550	1.4 (3)	25.0	49.8	74.8	124.9	208.0	374.2
575	1.4 (3)	24.0	47.9	71.8	119.7	199.5	359.1
600	1.4 (3)	20.3	40.5	60.8	101.3	168.9	304.0
625	1.4 (3)	15.8	31.6	47.4	79.1	131.8	237.2
650	1.4 (3)	12.6	25.3	37.9	63.2	105.4	189.6
675	1.4 (3)	9.9	19.8	29.6	49.4	82.3	148.1
700	1.4 (3)	7.9	15.8	23.7	39.5	65.9	118.6
725	1.4 (3)	6.3	12.7	19.0	31.7	52.8	95.1
750	1.4 (3)	5.0	10.0	15.0	25.0	41.7	75.0
775	1.4 (3)	4.0	8.0	11.9	19.9	33.2	59.7
800	1.2 (3)	3.1	6.3	9.4	15.6	26.1	46.9
816	1.0 (3)	2.6	5.2	7.8	13.0	21.7	39.0
<b>B — Special Class</b>							
Temperature, °C	Working Pressures by Class, bar						
	150	300	600	900	1500	2500	4500
-29 to 38	19.8	51.7	103.4	155.1	258.6	430.9	775.7
50	19.6	51.1	102.3	153.4	255.6	426.0	766.9
100	18.7	48.7	97.3	146.0	243.3	405.5	729.9
150	17.5	45.7	91.5	137.2	228.7	381.1	686.0
200	16.4	42.7	85.5	128.2	213.7	356.2	641.1
250	15.4	40.2	80.4	120.6	201.0	335.0	603.1

**Table 2-2.4 Ratings for Group 2.4 Materials (Cont'd)**

<b>B — Special Class</b>							
<b>Temperature, °C</b>	<b>Working Pressures by Class, bar</b>						
	<b>150</b>	<b>300</b>	<b>600</b>	<b>900</b>	<b>1500</b>	<b>2500</b>	<b>4500</b>
300	14.6	38.1	76.2	114.3	190.6	317.6	571.7
325	14.3	37.2	74.4	111.5	185.9	309.8	557.6
350	13.9	36.4	72.8	109.2	181.9	303.2	545.8
375	13.7	35.8	71.5	107.3	178.8	297.9	536.3
400	13.5	35.3	70.5	105.8	176.3	293.8	528.8
425	13.3	34.8	69.5	104.3	173.8	289.6	521.3
450	13.2	34.4	68.8	103.2	172.0	286.7	516.1
475	13.1	34.1	68.2	102.2	170.4	284.0	511.2
500	12.9	33.7	67.5	101.2	168.7	281.2	506.2
538	11.0	29.0	57.9	86.9	145.1	241.7	435.1
550	11.0	29.0	57.9	86.9	145.1	241.7	435.1
575	10.9	28.6	57.1	85.7	143.0	238.3	428.8
600	9.7	25.3	50.7	76.0	126.6	211.1	379.9
625	7.6	19.8	39.5	59.3	98.8	164.7	296.5
650	6.1	15.8	31.6	47.4	79.0	131.7	237.0
675	4.7	12.3	24.7	37.0	61.7	102.9	185.2
700	4.2	10.8	21.7	32.5	54.2	90.3	162.5
725	3.4	8.9	17.7	26.6	44.3	73.8	132.9
750	2.6	6.7	13.4	20.0	33.4	55.7	100.2
775	1.9	5.0	10.0	15.0	25.1	41.8	75.2
800	1.7	4.4	8.8	13.2	22.0	36.6	65.6
816	1.2	3.3	6.5	9.8	16.3	27.1	48.8

## NOTES:

(1) Not to be used over 538°C.

(2) At temperatures above 538°C, use only if the material is heat treated by heating to a minimum temperature of 1 095°C.

(3) Flanged-end valve ratings terminate at 538°C.

**Table 2-2.5 Ratings for Group 2.5 Materials**

A182 Gr. F347 (1)	A240 Gr. 348 (1)	A358 Gr. 347 (1)	A430 Gr. FP347H
A182 Gr. F347H (2)	A240 Gr. 348H (2)	A376 Gr. TP347 (1)	A479 Gr. 347 (1)
A182 Gr. F348 (1)	A312 Gr. TP347 (1)	A376 Gr. TP347H	A479 Gr. 347H
A182 Gr. F348H (2)	A312 Gr. TP347H	A376 Gr. TP348 (1)	A479 Gr. 348 (1)
A240 Gr. 347 (1)	A312 Gr. TP348 (1)	A376 Gr. TP348H (1)	A479 Gr. 348H
A240 Gr. 347H (2)	A312 Gr. TP348H	A430 Gr. FP347 (1)	

**A — Standard Class**

Temperature, °C	Working Pressures by Class, bar						
	150	300	600	900	1500	2500	4500
-29 to 38	19.0	49.6	99.3	148.9	248.2	413.7	744.6
50	18.7	48.8	97.5	146.3	243.8	406.4	731.5
100	17.4	45.3	90.6	135.9	226.5	377.4	679.4
150	15.8	42.5	84.9	127.4	212.4	353.9	637.1
200	13.8	39.9	79.9	119.8	199.7	332.8	599.1
250	12.1	37.8	75.6	113.4	189.1	315.1	567.2
300	10.2	36.1	72.2	108.3	180.4	300.7	541.3
325	9.3	35.4	70.7	106.1	176.8	294.6	530.3
350	8.4	34.8	69.5	104.3	173.8	289.6	521.3
375	7.4	34.2	68.4	102.6	171.0	285.1	513.1
400	6.5	33.9	67.8	101.7	169.5	282.6	508.6
425	5.5	33.6	67.2	100.8	168.1	280.1	504.2
450	4.6	33.5	66.9	100.4	167.3	278.8	501.8
475	3.7	31.7	63.4	95.1	158.2	263.9	474.8
500	2.8	28.2	56.5	84.7	140.9	235.0	423.0
538	1.4	25.2	50.0	75.2	125.5	208.9	375.8
550	1.4 (3)	25.0	49.8	74.8	124.9	208.0	374.2
575	1.4 (3)	24.0	47.9	71.8	119.7	199.5	359.1
600	1.4 (3)	21.6	42.9	64.2	107.0	178.5	321.4
625	1.4 (3)	18.3	36.6	54.9	91.2	152.0	273.8
650	1.4 (3)	14.1	28.1	42.5	70.7	117.7	211.7
675	1.4 (3)	12.4	25.2	37.6	62.7	104.5	187.9
700	1.4 (3)	10.1	20.0	29.8	49.7	83.0	149.4
725	1.4 (3)	7.9	15.4	23.2	38.6	64.4	115.8
750	1.4 (3)	5.9	11.7	17.6	29.6	49.1	88.2
775	1.4 (3)	4.6	9.0	13.7	22.8	38.0	68.4
800	1.2 (3)	3.5	7.0	10.5	17.4	29.2	52.6
816	1.0 (3)	2.8	5.9	8.6	14.1	23.8	42.7

**B — Special Class**

Temperature, °C	Working Pressures by Class, bar						
	150	300	600	900	1500	2500	4500
-29 to 38	20.0	51.7	103.4	155.1	258.6	430.9	775.7
50	20.0	51.7	103.4	155.1	258.6	430.9	775.7
100	19.4	50.6	101.1	151.7	252.8	421.3	758.3
150	18.2	47.4	94.8	142.2	237.0	395.0	711.0

**Table 2-2.5 Ratings for Group 2.5 Materials (Cont'd)**

<b>B — Special Class</b>							
<b>Temperature, °C</b>	<b>Working Pressures by Class, bar</b>						
	<b>150</b>	<b>300</b>	<b>600</b>	<b>900</b>	<b>1500</b>	<b>2500</b>	<b>4500</b>
200	17.1	44.6	89.1	133.7	222.9	371.5	668.6
250	16.2	42.2	84.4	126.6	211.0	351.7	633.0
300	15.4	40.3	80.6	120.8	201.4	335.6	604.1
325	15.1	39.5	78.9	118.4	197.3	328.8	591.8
350	14.9	38.8	77.6	116.4	194.0	323.3	581.9
375	14.6	38.2	76.4	114.5	190.9	318.1	572.7
400	14.5	37.8	75.7	113.5	189.2	315.4	567.7
425	14.4	37.5	75.0	112.5	187.6	312.6	562.7
450	14.3	37.3	74.7	112.0	186.7	311.1	560.0
475	14.3	37.3	74.6	111.9	186.5	310.9	559.6
500	13.7	35.6	71.5	107.1	178.6	297.5	535.4
538	11.0	29.0	57.9	86.9	145.1	241.7	435.1
550	11.0	29.0	57.9	86.9	145.1	241.7	435.1
575	10.9	28.6	57.1	85.7	143.0	238.3	428.8
600	10.3	26.9	53.5	80.4	134.0	223.4	401.9
625	8.7	23.0	45.7	68.6	114.3	190.6	342.8
650	6.9	17.9	35.5	53.1	88.6	147.9	266.1
675	6.2	16.0	31.6	47.3	78.9	131.7	237.0
700	4.8	12.4	25.0	37.3	62.3	103.7	186.5
725	3.7	9.7	19.5	28.9	48.3	80.2	144.5
750	2.8	7.4	14.8	22.1	36.7	61.2	110.3
775	2.2	5.8	11.4	17.2	28.5	47.6	85.6
800	1.8	4.4	8.8	13.2	22.0	36.6	65.6
816	1.4	3.4	7.2	10.7	17.9	29.6	53.1

## NOTES:

- (1) Not to be used over 538°C.
- (2) At temperatures above 538°C, use only if the material is heat treated by heating to a minimum temperature of 1 095°C.
- (3) Flanged-end valve ratings terminate at 538°C.

Table 2-2.6 Ratings for Group 2.6 Materials

A240 Gr. 309H	A312 Gr. TP309H		A358 Gr. 309H				
A — Standard Class							
Temperature, °C	Working Pressures by Class, bar						
	150	300	600	900	1500	2500	4500
-29 to 38	19.0	49.6	99.3	148.9	248.2	413.7	744.6
50	18.5	48.3	96.6	144.9	241.5	402.5	724.4
100	16.5	43.1	86.2	129.3	215.5	359.2	646.5
150	15.3	40.0	80.0	120.0	200.0	333.3	599.9
200	13.8	37.8	75.5	113.3	188.8	314.7	566.4
250	12.1	36.1	72.1	108.2	180.4	300.6	541.1
300	10.2	34.8	69.6	104.4	173.9	289.9	521.8
325	9.3	34.2	68.5	102.7	171.2	285.4	513.7
350	8.4	33.8	67.6	101.4	169.0	281.7	507.0
375	7.4	33.4	66.8	100.1	166.9	278.2	500.7
400	6.5	33.1	66.1	99.2	165.4	275.6	496.1
425	5.5	32.6	65.3	97.9	163.1	271.9	489.4
450	4.6	32.2	64.4	96.5	160.9	268.2	482.7
475	3.7	31.7	63.4	95.1	158.2	263.9	474.8
500	2.8	28.2	56.5	84.7	140.9	235.0	423.0
538	1.4	25.2	50.0	75.2	125.5	208.9	375.8
550	1.4 (1)	25.0	49.8	74.8	124.9	208.0	374.2
575	1.4 (1)	22.2	44.4	66.5	110.9	184.8	332.7
600	1.4 (1)	16.8	33.5	50.3	83.9	139.8	251.6
625	1.4 (1)	12.5	25.0	37.5	62.5	104.2	187.6
650	1.4 (1)	9.4	18.7	28.1	46.8	78.0	140.4
675	1.4 (1)	7.2	14.5	21.7	36.2	60.3	108.5
700	1.4 (1)	5.5	11.0	16.5	27.5	45.9	82.5
725	1.4 (1)	4.3	8.7	13.0	21.6	36.0	64.9
750	1.3 (1)	3.4	6.8	10.2	17.1	28.4	51.2
775	1.0 (1)	2.7	5.4	8.1	13.5	22.4	40.4
800	0.8 (1)	2.1	4.2	6.3	10.5	17.5	31.6
816	0.7 (1)	1.8	3.5	5.3	8.9	14.8	26.6
B — Special Class							
Temperature, °C	Working Pressures by Class, bar						
	150	300	600	900	1500	2500	4500
-29 to 38	20.0	51.7	103.4	155.1	258.6	430.9	775.7
50	20.0	51.7	103.4	155.1	258.6	430.9	775.7
100	18.4	48.1	96.2	144.3	240.5	400.9	721.6
150	17.1	44.6	89.3	133.9	223.2	372.0	669.6
200	16.2	42.1	84.3	126.4	210.7	351.2	632.2
250	15.4	40.3	80.5	120.8	201.3	335.5	603.9
300	14.9	38.8	77.7	116.5	194.1	323.6	582.4
325	14.7	38.2	76.5	114.7	191.1	318.5	573.4



**Table 2-2.6 Ratings for Group 2.6 Materials (Cont'd)**

<b>B — Special Class</b>							
<b>Temperature, °C</b>	<b>Working Pressures by Class, bar</b>						
	<b>150</b>	<b>300</b>	<b>600</b>	<b>900</b>	<b>1500</b>	<b>2500</b>	<b>4500</b>
350	14.5	37.7	75.5	113.2	188.6	314.4	565.9
375	14.3	37.3	74.5	111.8	186.3	310.4	558.8
400	14.2	36.9	73.8	110.7	184.6	307.6	553.7
425	14.0	36.4	72.8	109.2	182.1	303.5	546.2
450	13.8	35.9	71.8	107.8	179.6	299.3	538.8
475	13.6	35.4	70.8	106.3	177.1	295.2	531.3
500	13.4	34.9	69.8	104.8	174.6	291.0	523.8
538	11.0	29.0	57.9	86.9	145.1	241.7	435.1
550	11.0	29.0	57.9	86.9	145.1	241.7	435.1
575	10.6	27.7	55.4	83.2	138.6	231.0	415.8
600	8.0	21.0	41.9	62.9	104.8	174.7	314.5
625	6.0	15.6	31.3	46.9	78.2	130.3	234.5
650	4.5	11.7	23.4	35.1	58.5	97.5	175.5
675	3.5	9.0	18.1	27.1	45.2	75.3	135.6
700	3.0	7.7	15.4	23.2	38.6	64.4	115.9
725	2.3	6.1	12.1	18.2	30.4	50.6	91.1
750	1.7	4.6	9.1	13.7	22.8	37.9	68.3
775	1.3	3.4	6.8	10.2	16.9	28.2	50.8
800	1.1	3.0	5.9	8.9	14.8	24.7	44.5
816	0.8	2.2	4.4	6.6	11.1	18.5	33.2

NOTE: (1) Flanged-end valve ratings terminate at 538°C.

Table 2-2.7 Ratings for Group 2.7 Materials

		A312 Gr. TP310H		A479 Gr. 310H			
A182 Gr. F310		A358 Gr. 310H					
		A — Standard Class					
Temperature, °C	Working Pressures by Class, bar						
	150	300	600	900	1500	2500	4500
-29 to 38	19.0	49.6	99.3	148.9	248.2	413.7	744.6
50	18.5	48.4	96.7	145.1	241.8	403.1	725.5
100	16.6	43.4	86.8	130.2	217.0	361.6	650.9
150	15.3	40.0	80.0	120.0	200.0	333.3	599.9
200	13.8	37.6	75.2	112.8	188.0	313.4	564.1
250	12.1	35.8	71.5	107.3	178.8	298.1	536.5
300	10.2	34.5	68.9	103.4	172.3	287.2	516.9
325	9.3	33.9	67.7	101.6	169.3	282.2	507.9
350	8.4	33.3	66.6	99.9	166.5	277.6	499.6
375	7.4	32.9	65.7	98.6	164.3	273.8	492.9
400	6.5	32.4	64.8	97.3	162.1	270.2	486.3
425	5.5	32.1	64.2	96.4	160.6	267.7	481.8
450	4.6	31.7	63.4	95.1	158.4	264.0	475.3
475	3.7	31.2	62.5	93.7	156.2	260.3	468.6
500	2.8	28.2	56.5	84.7	140.9	235.0	423.0
538	1.4	25.2	50.0	75.2	125.5	208.9	375.8
550	1.4 (1)	25.0	49.8	74.8	124.9	208.0	374.2
575	1.4 (1)	22.2	44.4	66.5	110.9	184.8	332.7
600	1.4 (1)	16.8	33.5	50.3	83.9	139.8	251.6
625	1.4 (1)	12.5	25.0	37.5	62.5	104.2	187.6
650	1.4 (1)	9.4	18.7	28.1	46.8	78.0	140.4
675	1.4 (1)	7.2	14.5	21.7	36.2	60.3	108.5
700	1.4 (1)	5.5	11.0	16.5	27.5	45.9	82.5
725	1.4 (1)	4.3	8.7	13.0	21.6	36.0	64.9
750	1.3 (1)	3.4	6.8	10.2	17.1	28.4	51.2
775	1.0 (1)	2.7	5.3	8.0	13.3	22.1	39.8
800	0.8 (1)	2.1	4.1	6.2	10.3	17.2	31.0
816	0.7 (1)	1.8	3.5	5.3	8.9	14.8	26.6
		B — Special Class					
Temperature, °C	Working Pressures by Class, bar						
	150	300	600	900	1500	2500	4500
-29 to 38	20.0	51.7	103.4	155.1	258.6	430.9	775.7
50	20.0	51.7	103.4	155.1	258.6	430.9	775.7
100	18.6	48.4	96.9	145.3	242.2	403.6	726.5
150	17.1	44.6	89.3	133.9	223.2	371.9	669.5
200	16.1	42.0	83.9	125.9	209.9	349.8	629.6
250	15.3	39.9	79.8	119.8	199.6	332.7	598.8
300	14.7	38.5	76.9	115.4	192.3	320.5	576.9
325	14.5	37.8	75.6	113.4	189.0	314.9	566.9

**Table 2-2.7 Ratings for Group 2.7 Materials (Cont'd)**

<b>B — Special Class</b>							
<b>Temperature, °C</b>	<b>Working Pressures by Class, bar</b>						
	<b>150</b>	<b>300</b>	<b>600</b>	<b>900</b>	<b>1500</b>	<b>2500</b>	<b>4500</b>
350	14.2	37.2	74.3	111.5	185.9	309.8	557.6
375	14.1	36.7	73.3	110.0	183.4	305.6	550.1
400	13.9	36.2	72.4	108.5	180.9	301.5	542.7
425	13.7	35.9	71.7	107.6	179.3	298.8	537.8
450	13.6	35.4	70.7	106.1	176.8	294.7	530.4
475	13.4	34.9	69.7	104.6	174.3	290.5	523.0
500	13.2	34.4	68.7	103.1	171.8	286.4	515.5
538	11.0	29.0	57.9	86.9	145.1	241.7	435.1
550	11.0	29.0	57.9	86.9	145.1	241.7	435.1
575	10.6	27.7	55.4	83.2	138.6	231.0	415.8
600	8.0	21.0	41.9	62.9	104.8	174.7	314.5
625	6.0	15.6	31.3	46.9	78.2	130.3	234.5
650	4.5	11.7	23.4	35.1	58.5	97.5	175.5
675	3.5	9.0	18.1	27.1	45.2	75.3	135.6
700	3.0	7.7	15.4	23.2	38.6	64.4	115.9
725	2.3	6.1	12.1	18.2	30.4	50.6	91.1
750	1.7	4.6	9.1	13.7	22.8	37.9	68.3
775	1.3	3.3	6.7	10.0	16.7	27.9	50.1
800	1.1	2.9	5.8	8.6	14.4	24.0	43.2
816	0.8	2.2	4.4	6.6	11.1	18.5	33.2

NOTE: (1) Flanged-end valve ratings terminate at 538°C.

(17)

**Table 2-2.8 Ratings for Group 2.8 Materials**

A182 Gr. F44	A240 Gr. S32760 (1)	A479 Gr. S32750 (1)	A790 Gr. S32750 (1)
A182 Gr. F51 (1)	A312 Gr. S31254	A479 Gr. S32760 (1)	A790 Gr. S32760 (1)
A182 Gr. F53 (1)	A351 Gr. CK3MCuN	A789 Gr. S31803 (1)	A995 Gr. CD3MN (1)
A182 Gr. F55	A358 Gr. S31254	A789 Gr. S32750 (1)	A995 Gr. CD3MWCuN
A240 Gr. S31254	A479 Gr. S31254	A789 Gr. S32760 (1)	A995 Gr. CD4MCuN (1)
A240 Gr. S31803 (1)	A479 Gr. S31803 (1)	A790 Gr. S31803 (1)	A995 Gr. CE8MN (1)
A240 Gr. S32750 (1)			

**A — Standard Class**

Temperature, °C	Working Pressures by Class, bar						
	150	300	600	900	1500	2500	4500
-29 to 38	20.0	51.7	103.4	155.1	258.6	430.9	775.7
50	19.5	51.7	103.4	155.1	258.6	430.9	775.7
100	17.7	50.7	101.3	152.0	253.3	422.2	759.9
150	15.8	45.9	91.9	137.8	229.6	382.7	688.9
200	13.8	42.7	85.3	128.0	213.3	355.4	639.8
250	12.1	40.5	80.9	121.4	202.3	337.2	606.9
300	10.2	38.9	77.7	116.6	194.3	323.8	582.8
325	9.3	38.2	76.3	114.5	190.8	318.0	572.5
350	8.4	37.6	75.3	112.9	188.2	313.7	564.7
375	7.4	37.4	74.7	112.1	186.8	311.3	560.3
400	6.5	36.5	73.3	109.8	183.1	304.9	548.5

**B — Special Class**

Temperature, °C	Working Pressures by Class, bar						
	150	300	600	900	1500	2500	4500
-29 to 38	20.0	51.7	103.4	155.1	258.6	430.9	775.7
50	20.0	51.7	103.4	155.1	258.6	430.9	775.7
100	20.0	51.7	103.4	155.1	258.6	430.9	775.7
150	19.6	51.3	102.5	153.8	256.3	427.2	768.9
200	18.2	47.6	95.2	142.8	238.0	396.7	714.1
250	17.3	45.2	90.3	135.5	225.8	376.3	677.4
300	16.6	43.4	86.7	130.1	216.8	361.4	650.4
325	16.3	42.6	85.2	127.8	213.0	355.0	638.9
350	16.1	42.0	84.0	126.1	210.1	350.2	630.3
375	16.0	41.7	83.4	125.1	208.4	347.4	625.3
400	15.2	39.7	79.4	119.1	198.6	330.9	595.7

NOTE: (1) This steel may become brittle after service at moderately elevated temperatures. Not to be used over 315°C.

**Table 2-2.9 Ratings for Group 2.9 Materials**

A240 Gr. 309S (1)-(3)		A240 Gr. 310S (1)-(3)		A479 Gr. 310S (1)-(3)			
<b>A — Standard Class</b>							
Temperature, °C	Working Pressures by Class, bar						
	150	300	600	900	1500	2500	4500
-29 to 38	19.0	49.6	99.3	148.9	248.2	413.7	744.6
50	18.5	48.3	96.6	144.9	241.5	402.5	724.4
100	16.5	43.1	86.2	129.3	215.5	359.2	646.5
150	15.3	40.0	80.0	120.0	200.0	333.3	599.9
200	13.8	37.6	75.2	112.8	188.0	313.4	564.1
250	12.1	35.8	71.5	107.3	178.8	298.1	536.5
300	10.2	34.5	68.9	103.4	172.3	287.2	516.9
325	9.3	33.9	67.7	101.6	169.3	282.2	507.9
350	8.4	33.3	66.6	99.9	166.5	277.6	499.6
375	7.4	32.9	65.7	98.6	164.3	273.8	492.9
400	6.5	32.4	64.8	97.3	162.1	270.2	486.3
425	5.5	32.1	64.2	96.4	160.6	267.7	481.8
450	4.6	31.7	63.4	95.1	158.4	264.0	475.3
475	3.7	31.2	62.5	93.7	156.2	260.3	468.6
500	2.8	28.2	56.5	84.7	140.9	235.0	423.0
538	1.4	23.4	46.8	70.2	117.0	195.0	351.0
550	1.4 (4)	20.5	41.0	61.5	102.5	170.8	307.4
575	1.4 (4)	15.1	30.2	45.3	75.5	125.8	226.4
600	1.4 (4)	11.0	22.1	33.1	55.1	91.9	165.4
625	1.4 (4)	8.1	16.3	24.4	40.7	67.9	122.2
650	1.4 (4)	5.8	11.6	17.4	29.1	48.5	87.2
675	1.4 (4)	3.7	7.4	11.1	18.4	30.7	55.3
700	0.8 (4)	2.2	4.3	6.5	10.8	18.0	32.3
725	0.5 (4)	1.4	2.7	4.1	6.8	11.4	20.5
750	0.4 (4)	1.0	2.1	3.1	5.2	8.6	15.5
775	0.3 (4)	0.8	1.6	2.5	4.1	6.8	12.3
800	0.2 (4)	0.6	1.2	1.8	3.0	5.0	9.1
816	0.2 (4)	0.5	0.9	1.4	2.4	3.9	7.1
<b>B — Special Class</b>							
Temperature, °C	Working Pressures by Class, bar						
	150	300	600	900	1500	2500	4500
-29 to 38	20.0	51.7	103.4	155.1	258.6	430.9	775.7
50	20.0	51.7	103.4	155.1	258.6	430.9	775.7
100	18.4	48.1	96.2	144.3	240.5	400.9	721.6
150	17.1	44.6	89.3	133.9	223.2	371.9	669.5
200	16.1	42.0	83.9	125.9	209.9	349.8	629.6
250	15.3	39.9	79.8	119.8	199.6	332.7	598.8
300	14.7	38.5	76.9	115.4	192.3	320.5	576.9
325	14.5	37.8	75.6	113.4	189.0	314.9	566.9

**Table 2-2.9 Ratings for Group 2.9 Materials (Cont'd)**

<b>B — Special Class</b>							
<b>Temperature, °C</b>	<b>Working Pressures by Class, bar</b>						
	<b>150</b>	<b>300</b>	<b>600</b>	<b>900</b>	<b>1500</b>	<b>2500</b>	<b>4500</b>
350	14.2	37.2	74.3	111.5	185.9	309.8	557.6
375	14.1	36.7	73.3	110.0	183.4	305.6	550.1
400	13.9	36.2	72.4	108.5	180.9	301.5	542.7
425	13.7	35.9	71.7	107.6	179.3	298.8	537.8
450	13.6	35.4	70.7	106.1	176.8	294.7	530.4
475	13.4	34.9	69.7	104.6	174.3	290.5	523.0
500	13.2	34.4	68.7	103.1	171.8	286.4	515.5
538	11.0	29.0	57.9	86.9	145.1	241.7	435.1
550	9.8	25.6	51.2	76.8	128.1	213.4	384.2
575	7.2	18.9	37.7	56.6	94.3	157.2	283.0
600	5.3	13.8	27.6	41.3	68.9	114.8	206.7
625	3.9	10.2	20.4	30.5	50.9	84.9	152.7
650	2.8	7.3	14.5	21.8	36.3	60.6	109.0
675	1.8	4.6	9.2	13.8	23.0	38.4	69.1
700	1.3	3.4	6.9	10.3	17.2	28.6	51.5
725	0.8	2.1	4.2	6.3	10.5	17.6	31.6
750	0.5	1.4	2.7	4.1	6.8	11.3	20.4
775	0.4	1.0	2.1	3.1	5.2	8.6	15.5
800	0.3	0.9	1.8	2.7	4.5	7.4	13.4
816	0.2	0.6	1.2	1.8	3.0	4.9	8.9

## NOTES:

- (1) At temperatures above 538°C, use only when the carbon content is 0.04% or higher.
- (2) For temperatures above 538°C, use only if the material is solution heat treated to the minimum temperature specified in the material specification but not lower than 1 040°C and quenching in water or rapidly cooling by other means.
- (3) This material should be used for service temperatures 515°C and above only when assurance is provided that grain size is not finer than ASTM 6.
- (4) Flanged-end valve ratings terminate at 538°C.

**Table 2-2.10 Ratings for Group 2.10 Materials**

A351 Gr. CH8 (1)		A351 Gr. CH20 (1)					
A — Standard Class							
Temperature, °C	Working Pressures by Class, bar						
	150	300	600	900	1500	2500	4500
-29 to 38	17.8	46.3	92.7	139.0	231.7	386.1	695.0
50	17.0	44.5	89.0	133.4	222.4	370.6	667.1
100	14.4	37.5	75.1	112.6	187.7	312.8	563.0
150	13.4	34.9	69.8	104.7	174.4	290.7	523.3
200	12.9	33.5	67.1	100.6	167.7	279.5	503.2
250	12.1	32.6	65.2	97.8	163.1	271.8	489.2
300	10.2	31.7	63.4	95.2	158.6	264.3	475.8
325	9.3	31.2	62.4	93.6	156.1	260.1	468.2
350	8.4	30.6	61.2	91.7	152.9	254.8	458.7
375	7.4	29.8	59.7	89.5	149.2	248.6	447.5
400	6.5	29.1	58.2	87.3	145.5	242.4	436.4
425	5.5	28.3	56.7	85.0	141.7	236.2	425.2
450	4.6	27.6	55.2	82.8	138.0	230.0	414.0
475	3.7	26.7	53.5	80.2	133.7	222.8	401.0
500	2.8	25.8	51.7	77.5	129.2	215.3	387.6
538	1.4	23.3	46.6	70.0	116.6	194.4	349.9
550	1.4 (2)	21.9	43.8	65.7	109.5	182.5	328.5
575	1.4 (2)	18.5	37.0	55.5	92.4	154.0	277.3
600	1.4 (2)	14.5	29.0	43.5	72.6	121.0	217.7
625	1.4 (2)	11.4	22.8	34.3	57.1	95.2	171.3
650	1.4 (2)	8.9	17.8	26.7	44.5	74.1	133.5
675	1.4 (2)	7.0	14.0	20.9	34.9	58.2	104.7
700	1.4 (2)	5.7	11.3	17.0	28.3	47.2	85.0
725	1.4 (2)	4.6	9.1	13.7	22.8	38.0	68.4
750	1.3 (2)	3.5	7.0	10.5	17.5	29.2	52.5
775	1.0 (2)	2.6	5.1	7.7	12.8	21.4	38.4
800	0.8 (2)	2.0	4.0	6.1	10.1	16.9	30.4
816	0.7 (2)	1.9	3.8	5.7	9.5	15.8	28.4
B — Special Class							
Temperature, °C	Working Pressures by Class, bar						
	150	300	600	900	1500	2500	4500
-29 to 38	18.4	48.0	96.0	144.1	240.1	400.1	720.3
50	17.9	46.8	93.5	140.3	233.8	389.6	701.4
100	16.1	41.9	83.8	125.7	209.5	349.1	628.4
150	14.9	38.9	77.9	116.8	194.7	324.5	584.0
200	14.4	37.4	74.9	112.3	187.2	312.0	561.6
250	14.0	36.4	72.8	109.2	182.0	303.3	546.0
300	13.6	35.4	70.8	106.2	177.0	295.0	531.0
325	13.4	34.8	69.7	104.5	174.2	290.3	522.6

**Table 2-2.10 Ratings for Group 2.10 Materials (Cont'd)**

<b>B — Special Class</b>							
<b>Temperature, °C</b>	<b>Working Pressures by Class, bar</b>						
	<b>150</b>	<b>300</b>	<b>600</b>	<b>900</b>	<b>1500</b>	<b>2500</b>	<b>4500</b>
350	13.1	34.1	68.3	102.4	170.6	284.4	511.9
375	12.8	33.3	66.6	99.9	166.5	277.5	499.5
400	12.4	32.5	64.9	97.4	162.3	270.6	487.0
425	12.1	31.6	63.3	94.9	158.2	263.6	474.5
450	11.8	30.8	61.6	92.4	154.0	256.7	462.1
475	11.4	29.8	59.7	89.5	149.2	248.6	447.6
500	11.1	28.8	57.7	86.5	144.2	240.3	432.6
538	10.5	27.3	54.7	82.0	136.7	227.8	410.0
550	10.1	26.4	52.7	79.1	131.8	219.6	395.4
575	8.9	23.1	46.2	69.3	115.5	192.6	346.6
600	7.0	18.1	36.3	54.4	90.7	151.2	272.1
625	5.5	14.3	28.6	42.8	71.4	119.0	214.2
650	4.3	11.1	22.2	33.4	55.6	92.7	166.8
675	3.3	8.7	17.5	26.2	43.6	72.7	130.9
700	3.0	7.7	15.4	23.1	38.6	64.3	115.7
725	2.4	6.4	12.7	19.1	31.8	53.1	95.5
750	1.8	4.7	9.5	14.2	23.6	39.4	70.9
775	1.2	3.2	6.5	9.7	16.2	27.0	48.6
800	1.0	2.7	5.3	8.0	13.3	22.2	40.0
816	0.9	2.4	4.7	7.1	11.8	19.7	35.5

## NOTES:

- (1) At temperatures above 538°C, use only when the carbon content is 0.04% or higher.  
(2) Flanged-end valve ratings terminate at 538°C.



**Table 2-2.11 Ratings for Group 2.11 Materials**

A351 Gr. CF8C (1)							
A — Standard Class							
Temperature, °C	Working Pressures by Class, bar						
	150	300	600	900	1500	2500	4500
-29 to 38	19.0	49.6	99.3	148.9	248.2	413.7	744.6
50	18.7	48.8	97.5	146.3	243.8	406.4	731.5
100	17.4	45.3	90.6	135.9	226.5	377.4	679.4
150	15.8	42.5	84.9	127.4	212.4	353.9	637.1
200	13.8	39.9	79.9	119.8	199.7	332.8	599.1
250	12.1	37.8	75.6	113.4	189.1	315.1	567.2
300	10.2	36.1	72.2	108.3	180.4	300.7	541.3
325	9.3	35.4	70.7	106.1	176.8	294.6	530.3
350	8.4	34.8	69.5	104.3	173.8	289.6	521.3
375	7.4	34.2	68.4	102.6	171.0	285.1	513.1
400	6.5	33.9	67.8	101.7	169.5	282.6	508.6
425	5.5	33.6	67.2	100.8	168.1	280.1	504.2
450	4.6	33.5	66.9	100.4	167.3	278.8	501.8
475	3.7	31.7	63.4	95.1	158.2	263.9	474.8
500	2.8	28.2	56.5	84.7	140.9	235.0	423.0
538	1.4	25.2	50.0	75.2	125.5	208.9	375.8
550	1.4 (2)	25.0	49.8	74.8	124.9	208.0	374.2
575	1.4 (2)	24.0	47.9	71.8	119.7	199.5	359.1
600	1.4 (2)	19.8	39.6	59.4	99.0	165.1	297.1
625	1.4 (2)	13.9	27.7	41.6	69.3	115.5	207.9
650	1.4 (2)	10.3	20.6	30.9	51.5	85.8	154.5
675	1.4 (2)	8.0	15.9	23.9	39.8	66.3	119.4
700	1.4 (2)	5.6	11.2	16.8	28.1	46.8	84.2
725	1.4 (2)	4.0	8.0	11.9	19.9	33.1	59.6
750	1.2 (2)	3.1	6.2	9.3	15.5	25.8	46.4
775	0.9 (2)	2.5	4.9	7.4	12.3	20.4	36.8
800	0.8 (2)	2.0	4.0	6.1	10.1	16.9	30.4
816	0.7 (2)	1.9	3.8	5.7	9.5	15.8	28.4
B — Special Class							
Temperature, °C	Working Pressures by Class, bar						
	150	300	600	900	1500	2500	4500
-29 to 38	19.8	51.7	103.4	155.1	258.6	430.9	775.7
50	19.6	51.2	102.4	153.6	256.0	426.7	768.1
100	18.8	48.9	97.9	146.8	244.7	407.8	734.1
150	17.4	45.4	90.8	136.1	226.9	378.2	680.7
200	16.5	43.1	86.1	129.2	215.3	358.8	645.8
250	16.0	41.6	83.3	124.9	208.2	347.0	624.5
300	15.4	40.2	80.3	120.5	200.9	334.8	602.6
325	15.1	39.5	78.9	118.4	197.3	328.8	591.8

**Table 2-2.11 Ratings for Group 2.11 Materials (Cont'd)**

<b>B — Special Class</b>							
<b>Temperature, °C</b>	<b>Working Pressures by Class, bar</b>						
	<b>150</b>	<b>300</b>	<b>600</b>	<b>900</b>	<b>1500</b>	<b>2500</b>	<b>4500</b>
350	14.9	38.8	77.6	116.4	194.0	323.3	581.9
375	14.6	38.2	76.4	114.5	190.9	318.1	572.7
400	14.5	37.8	75.7	113.5	189.2	315.4	567.7
425	14.4	37.5	75.0	112.5	187.6	312.6	562.7
450	14.3	37.3	74.7	112.0	186.7	311.1	560.0
475	14.3	37.3	74.6	111.9	186.5	310.9	559.6
500	13.7	35.6	71.5	107.1	178.6	297.5	535.4
538	11.0	29.0	57.9	86.9	145.1	241.7	435.1
550	11.0	29.0	57.9	86.9	145.1	241.7	435.1
575	10.9	28.6	57.1	85.7	143.0	238.3	428.8
600	9.5	24.8	49.5	74.3	123.8	206.4	371.4
625	6.6	17.3	34.6	52.0	86.6	144.3	259.8
650	4.9	12.9	25.7	38.6	64.4	107.3	193.1
675	3.8	9.9	19.9	29.8	49.7	82.9	149.2
700	3.1	8.2	16.4	24.5	40.9	68.2	122.7
725	2.3	5.9	11.8	17.7	29.5	49.2	88.5
750	1.6	4.1	8.2	12.2	20.4	34.0	61.2
775	1.2	3.1	6.2	9.3	15.5	25.8	46.4
800	1.0	2.7	5.3	8.0	13.3	22.2	40.0
816	0.9	2.4	4.7	7.1	11.8	19.7	35.5

## NOTES:

- (1) At temperatures above 538°C, use only when the carbon content is 0.04% or higher.  
(2) Flanged-end valve ratings terminate at 538°C.

**Table 2-2.12 Ratings for Group 2.12 Materials**

A351 Gr. CK20 (1)							
A — Standard Class							
Temperature, °C	Working Pressures by Class, bar						
	150	300	600	900	1500	2500	4500
-29 to 38	17.8	46.3	92.7	139.0	231.7	386.1	695.0
50	17.0	44.5	89.0	133.4	222.4	370.6	667.1
100	14.4	37.5	75.1	112.6	187.7	312.8	563.0
150	13.4	34.9	69.8	104.7	174.4	290.7	523.3
200	12.9	33.5	67.1	100.6	167.7	279.5	503.2
250	12.1	32.6	65.2	97.8	163.1	271.8	489.2
300	10.2	31.7	63.4	95.2	158.6	264.3	475.8
325	9.3	31.2	62.4	93.6	156.1	260.1	468.2
350	8.4	30.6	61.2	91.7	152.9	254.8	458.7
375	7.4	29.8	59.7	89.5	149.2	248.6	447.5
400	6.5	29.1	58.2	87.3	145.5	242.4	436.4
425	5.5	28.3	56.7	85.0	141.7	236.2	425.2
450	4.6	27.6	55.2	82.8	138.0	230.0	414.0
475	3.7	26.7	53.5	80.2	133.7	222.8	401.0
500	2.8	25.8	51.7	77.5	129.2	215.3	387.6
538	1.4	23.3	46.6	70.0	116.6	194.4	349.9
550	1.4 (2)	22.9	45.9	68.8	114.7	191.2	344.1
575	1.4 (2)	21.7	43.3	65.0	108.3	180.4	324.8
600	1.4 (2)	19.4	38.8	58.2	97.1	161.8	291.2
625	1.4 (2)	16.8	33.7	50.5	84.1	140.2	252.4
650	1.4 (2)	14.1	28.1	42.2	70.4	117.3	211.1
675	1.4 (2)	11.5	23.0	34.6	57.6	96.0	172.8
700	1.4 (2)	8.8	17.5	26.3	43.8	73.0	131.5
725	1.4 (2)	6.3	12.7	19.0	31.7	52.9	95.2
750	1.4 (2)	4.5	8.9	13.4	22.3	37.2	66.9
775	1.2 (2)	3.1	6.3	9.4	15.7	26.2	47.2
800	0.9 (2)	2.3	4.6	6.9	11.4	19.1	34.3
816	0.7 (2)	1.9	3.8	5.7	9.5	15.8	28.4
B — Special Class							
Temperature, °C	Working Pressures by Class, bar						
	150	300	600	900	1500	2500	4500
-29 to 38	18.4	48.0	96.0	144.1	240.1	400.1	720.3
50	17.9	46.8	93.5	140.3	233.8	389.6	701.4
100	16.1	41.9	83.8	125.7	209.5	349.1	628.4
150	14.9	38.9	77.9	116.8	194.7	324.5	584.0
200	14.4	37.4	74.9	112.3	187.2	312.0	561.6
250	14.0	36.4	72.8	109.2	182.0	303.3	546.0
300	13.6	35.4	70.8	106.2	177.0	295.0	531.0
325	13.4	34.8	69.7	104.5	174.2	290.3	522.6

**Table 2-2.12 Ratings for Group 2.12 Materials (Cont'd)**

<b>B — Special Class</b>							
<b>Temperature, °C</b>	<b>Working Pressures by Class, bar</b>						
	<b>150</b>	<b>300</b>	<b>600</b>	<b>900</b>	<b>1500</b>	<b>2500</b>	<b>4500</b>
350	13.1	34.1	68.3	102.4	170.6	284.4	511.9
375	12.8	33.3	66.6	99.9	166.5	277.5	499.5
400	12.4	32.5	64.9	97.4	162.3	270.6	487.0
425	12.1	31.6	63.3	94.9	158.2	263.6	474.5
450	11.8	30.8	61.6	92.4	154.0	256.7	462.1
475	11.4	29.8	59.7	89.5	149.2	248.6	447.6
500	11.1	28.8	57.7	86.5	144.2	240.3	432.6
538	10.5	27.3	54.7	82.0	136.7	227.8	410.0
550	10.5	27.3	54.7	82.0	136.7	227.8	410.0
575	10.4	27.1	54.1	81.2	135.3	225.6	406.0
600	9.3	24.3	48.5	72.8	121.3	202.2	364.0
625	8.1	21.0	42.1	63.1	105.2	175.3	315.5
650	6.7	17.6	35.2	52.8	87.9	146.6	263.8
675	5.5	14.4	28.8	43.2	72.0	120.0	215.9
700	4.7	12.3	24.7	37.0	61.6	102.7	184.9
725	3.6	9.4	18.8	28.2	47.0	78.4	141.0
750	2.4	6.1	12.3	18.4	30.7	51.2	92.2
775	1.5	4.0	7.9	11.9	19.9	33.1	59.6
800	1.3	3.3	6.5	9.8	16.3	27.2	49.0
816	0.9	2.4	4.7	7.1	11.8	19.7	35.5

## NOTES:

- (1) At temperatures above 538°C, use only when the carbon content is 0.04% or higher.  
(2) Flanged-end valve ratings terminate at 538°C.

**Table 2-3.1 Ratings for Group 3.1 Materials**

B462 Gr. N08020 (1)		B464 Gr. N08020 (1)		B473 Gr. N08020 (1)		B463 Gr. N08020 (1)		B468 Gr. N08020 (1)	
<b>A — Standard Class</b>									
Temperature, °C	Working Pressures by Class, bar								
	150	300	600	900	1500	2500	4500		
-29 to 38	20.0	51.7	103.4	155.1	258.6	430.9	775.7		
50	19.5	51.7	103.4	155.1	258.6	430.9	775.7		
100	17.7	50.9	101.7	152.6	254.4	423.9	763.1		
150	15.8	48.9	97.9	146.8	244.7	407.8	734.1		
200	13.8	47.2	94.3	141.5	235.8	392.9	707.3		
250	12.1	45.5	91.0	136.5	227.5	379.2	682.5		
300	10.2	42.9	85.7	128.6	214.4	357.1	642.6		
325	9.3	41.4	82.6	124.0	206.6	344.3	619.6		
350	8.4	40.3	80.4	120.7	201.1	335.3	603.3		
375	7.4	38.9	77.6	116.5	194.1	323.2	581.8		
400	6.5	36.5	73.3	109.8	183.1	304.9	548.5		
425	5.5	35.2	70.0	105.1	175.1	291.6	524.7		
<b>B — Special Class</b>									
Temperature, °C	Working Pressures by Class, bar								
	150	300	600	900	1500	2500	4500		
-29 to 38	20.0	51.7	103.4	155.1	258.6	430.9	775.7		
50	20.0	51.7	103.4	155.1	258.6	430.9	775.7		
100	20.0	51.7	103.4	155.1	258.6	430.9	775.7		
150	20.0	51.7	103.4	155.1	258.6	430.9	775.7		
200	20.0	51.7	103.4	155.1	258.6	430.9	775.7		
250	19.5	50.8	101.6	152.4	253.9	423.2	761.8		
300	18.9	49.4	98.7	148.1	246.8	411.3	740.3		
325	18.7	48.8	97.5	146.3	243.8	406.3	731.3		
350	18.5	48.3	96.6	144.9	241.5	402.5	724.5		
375	18.4	48.0	95.9	143.9	239.8	399.7	719.5		
400	18.2	47.6	95.2	142.8	238.0	396.7	714.1		
425	17.9	46.6	93.2	139.8	233.0	388.4	699.1		

NOTE: (1) Use annealed material only.

**Table 2-3.2 Ratings for Group 3.2 Materials**

B160 Gr. N02200 (1)	B162 Gr. N02200 (1)	B163 Gr. N02200 (1)	B564 Gr. N02200 (1)				
B161 Gr. N02200 (1)							
<b>A — Standard Class</b>							
Temperature, °C	Working Pressures by Class, bar						
	150	300	600	900	1500	2500	4500
-29 to 38	12.7	33.1	66.2	99.3	165.5	275.8	496.4
50	12.7	33.1	66.2	99.3	165.5	275.8	496.4
100	12.7	33.1	66.2	99.3	165.5	275.8	496.4
150	12.7	33.1	66.2	99.3	165.5	275.8	496.4
200	12.7	33.1	66.2	99.3	165.5	275.8	496.4
250	12.1	31.6	63.2	94.8	158.0	263.4	474.0
300	10.2	29.2	58.5	87.7	146.2	243.7	438.7
325	7.2	18.8	37.6	56.4	93.9	156.5	281.8
<b>B — Special Class</b>							
Temperature, °C	Working Pressures by Class, bar						
	150	300	600	900	1500	2500	4500
-29 to 38	14.2	36.9	73.9	110.8	184.7	307.8	554.0
50	14.2	36.9	73.9	110.8	184.7	307.8	554.0
100	14.2	36.9	73.9	110.8	184.7	307.8	554.0
150	14.2	36.9	73.9	110.8	184.7	307.8	554.0
200	14.2	36.9	73.9	110.8	184.7	307.8	554.0
250	13.5	35.3	70.5	105.8	176.4	293.9	529.1
300	12.5	32.6	65.3	97.9	163.2	272.0	489.7
325	8.0	21.0	41.9	62.9	104.8	174.7	314.5

NOTE: (1) Only use annealed material.

**Table 2-3.3 Ratings for Group 3.3 Materials**

B160 Gr. N02201 (1)		B162 Gr. N02201 (1)					
A — Standard Class							
Temperature, °C	Working Pressures by Class, bar						
	150	300	600	900	1500	2500	4500
-29 to 38	6.3	16.5	33.1	49.6	82.7	137.9	248.2
50	6.3	16.4	32.8	49.2	82.0	136.7	246.0
100	6.1	15.8	31.7	47.5	79.2	132.0	237.7
150	6.0	15.6	31.1	46.7	77.8	129.6	233.3
200	6.0	15.6	31.1	46.7	77.8	129.6	233.3
250	6.0	15.6	31.1	46.7	77.8	129.6	233.3
300	6.0	15.6	31.1	46.7	77.8	129.6	233.3
325	5.9	15.5	31.0	46.5	77.5	129.2	232.5
350	5.9	15.4	30.8	46.2	76.9	128.2	230.8
375	5.9	15.4	30.7	46.1	76.8	128.0	230.5
400	5.8	15.2	30.4	45.6	76.1	126.8	228.2
425	5.5	14.9	29.8	44.7	74.6	124.3	223.7
450	4.6	14.6	29.2	43.8	73.1	121.8	219.2
475	3.7	14.3	28.6	43.0	71.6	119.3	214.8
500	2.8	13.8	27.6	41.4	69.0	115.1	207.1
538	1.4	13.1	26.1	39.2	65.4	108.9	196.1
550	1.4 (2)	9.8	19.6	29.5	49.1	81.8	147.3
575	1.4 (2)	5.4	10.7	16.1	26.8	44.6	80.3
600	1.4 (2)	4.4	8.9	13.3	22.2	37.0	66.7
625	1.3 (2)	3.4	6.9	10.3	17.2	28.7	51.7
650	1.1 (2)	2.8	5.7	8.5	14.2	23.6	42.6
B — Special Class							
Temperature, °C	Working Pressures by Class, bar						
	150	300	600	900	1500	2500	4500
-29 to 38	7.1	18.5	36.9	55.4	92.3	153.9	277.0
50	7.0	18.3	36.6	54.9	91.5	152.5	274.6
100	6.8	17.7	35.4	53.1	88.4	147.4	265.3
150	6.7	17.4	34.7	52.1	86.8	144.7	260.4
200	6.7	17.4	34.7	52.1	86.8	144.7	260.4
250	6.7	17.4	34.7	52.1	86.8	144.7	260.4
300	6.7	17.4	34.7	52.1	86.8	144.7	260.4
325	6.6	17.3	34.6	51.9	86.5	144.1	259.5
350	6.6	17.2	34.4	51.5	85.9	143.1	257.6
375	6.6	17.1	34.3	51.4	85.7	142.9	257.2
400	6.5	17.0	34.0	50.9	84.9	141.5	254.6
425	6.4	16.6	33.3	49.9	83.2	138.7	249.7
450	6.3	16.3	32.6	48.9	81.6	135.9	244.7
475	6.1	16.0	32.0	47.9	79.9	133.2	239.7
500	5.9	15.4	30.8	46.2	77.0	128.4	231.1
538	5.6	14.6	29.2	43.8	72.9	121.6	218.8
550	4.3	11.3	22.6	33.9	56.5	94.1	169.4

**Table 2-3.3 Ratings for Group 3.3 Materials (Cont'd)**

<b>B — Special Class</b>							
<b>Temperature, °C</b>	<b>Working Pressures by Class, bar</b>						
	<b>150</b>	<b>300</b>	<b>600</b>	<b>900</b>	<b>1500</b>	<b>2500</b>	<b>4500</b>
575	2.6	6.7	13.4	20.1	33.4	55.7	100.3
600	2.1	5.6	11.1	16.7	27.8	46.3	83.3
625	1.7	4.3	8.6	12.9	21.5	35.9	64.6
650	1.4	3.5	7.1	10.6	17.7	29.5	53.2

## NOTES:

- (1) Only use annealed material.  
(2) Flanged-end valve ratings terminate at 538°C.



**Table 2-3.4 Ratings for Group 3.4 Materials**

A494 Gr. M35-1 (1)	B127 Gr. N04400 (1)	B164 Gr. N04400 (1)	B165 Gr. N04400 (1)
A494 Gr. M35-2 (1)	B163 Gr. N04400 (1)	B164 Gr. N04405 (1)	B564 Gr. N04400 (1)

**A — Standard Class**

Temperature, °C	Working Pressures by Class, bar						
	150	300	600	900	1500	2500	4500
-29 to 38	15.9	41.4	82.7	124.1	206.8	344.7	620.5
50	15.4	40.2	80.5	120.7	201.2	335.3	603.6
100	13.8	35.9	71.9	107.8	179.7	299.5	539.1
150	12.9	33.7	67.5	101.2	168.7	281.1	506.0
200	12.5	32.7	65.4	98.1	163.5	272.4	490.4
250	12.1	32.6	65.2	97.8	163.0	271.7	489.0
300	10.2	32.6	65.2	97.8	163.0	271.7	489.0
325	9.3	32.6	65.2	97.8	163.0	271.7	489.0
350	8.4	32.6	65.1	97.7	162.8	271.3	488.4
375	7.4	32.4	64.8	97.2	161.9	269.9	485.8
400	6.5	32.1	64.2	96.2	160.4	267.4	481.2
425	5.5	31.6	63.3	94.9	158.2	263.6	474.5
450	4.6	26.9	53.8	80.7	134.5	224.2	403.5
475	3.7	20.8	41.5	62.3	103.8	173.0	311.3

**B — Special Class**

Temperature, °C	Working Pressures by Class, bar						
	150	300	600	900	1500	2500	4500
-29 to 38	17.7	46.2	92.3	138.5	230.9	384.8	692.6
50	17.2	44.9	89.8	134.7	224.6	374.3	673.7
100	15.4	40.1	80.2	120.3	200.6	334.3	601.7
150	14.4	37.6	75.3	112.9	188.2	313.7	564.7
200	14.0	36.5	73.0	109.5	182.4	304.0	547.3
250	13.9	36.4	72.8	109.1	181.9	303.2	545.7
300	13.9	36.4	72.8	109.1	181.9	303.2	545.7
325	13.9	36.4	72.8	109.1	181.9	303.2	545.7
350	13.9	36.3	72.7	109.0	181.7	302.8	545.1
375	13.9	36.1	72.3	108.4	180.7	301.2	542.2
400	13.7	35.8	71.6	107.4	179.0	298.4	537.1
425	13.5	35.3	70.6	105.9	176.5	294.2	529.6
450	12.6	32.9	65.9	98.8	164.7	274.6	494.2
475	9.9	25.9	51.9	77.8	129.7	216.2	389.2

NOTE: (1) Only use annealed material.

Table 2-3.5 Ratings for Group 3.5 Materials

B163 Gr. N06600 (1)	B166 Gr. N06600 (1)		B168 Gr. N06600 (1)		B564 Gr. N06600 (1)		
A — Standard Class							
Temperature, °C	Working Pressures by Class, bar						
	150	300	600	900	1500	2500	4500
-29 to 38	20.0	51.7	103.4	155.1	258.6	430.9	775.7
50	19.5	51.7	103.4	155.1	258.6	430.9	775.7
100	17.7	51.5	103.0	154.6	257.6	429.4	773.0
150	15.8	50.3	100.3	150.6	250.8	418.2	752.8
200	13.8	48.6	97.2	145.8	243.4	405.4	729.8
250	12.1	46.3	92.7	139.0	231.8	386.2	694.8
300	10.2	42.9	85.7	128.6	214.4	357.1	642.6
325	9.3	41.4	82.6	124.0	206.6	344.3	619.6
350	8.4	40.3	80.4	120.7	201.1	335.3	603.3
375	7.4	38.9	77.6	116.5	194.1	323.2	581.8
400	6.5	36.5	73.3	109.8	183.1	304.9	548.5
425	5.5	35.2	70.0	105.1	175.1	291.6	524.7
450	4.6	33.7	67.7	101.4	169.0	281.8	507.0
475	3.7	31.7	63.4	95.1	158.2	263.9	474.8
500	2.8	28.2	56.5	84.7	140.9	235.0	423.0
538	1.4	16.5	33.1	49.6	82.7	137.9	248.2
550	1.4 (2)	13.9	27.9	41.8	69.7	116.2	209.2
575	1.4 (2)	9.4	18.9	28.3	47.2	78.6	141.5
600	1.4 (2)	6.6	13.3	19.9	33.2	55.3	99.6
625	1.4 (2)	5.1	10.3	15.4	25.7	42.8	77.0
650	1.4 (2)	4.7	9.5	14.2	23.6	39.4	70.9
B — Special Class							
Temperature, °C	Working Pressures by Class, bar						
	150	300	600	900	1500	2500	4500
-29 to 38	20.0	51.7	103.4	155.1	258.6	430.9	775.7
50	20.0	51.7	103.4	155.1	258.6	430.9	775.7
100	20.0	51.7	103.4	155.1	258.6	430.9	775.7
150	20.0	51.7	103.4	155.1	258.6	430.9	775.7
200	20.0	51.7	103.4	155.1	258.6	430.9	775.7
250	20.0	51.7	103.4	155.1	258.6	430.9	775.7
300	20.0	51.7	103.4	155.1	258.6	430.9	775.7
325	20.0	51.7	103.4	155.1	258.6	430.9	775.7
350	19.8	51.5	102.8	154.3	257.1	428.6	771.4
375	19.3	50.6	101.0	151.5	252.5	420.9	757.4
400	19.3	50.3	100.6	150.6	251.2	418.3	753.2
425	19.0	49.6	99.3	148.9	248.2	413.7	744.6
450	18.1	47.3	94.4	141.4	235.8	393.1	707.6
475	16.4	42.8	85.5	128.2	213.7	356.3	641.3
500	13.7	35.6	71.5	107.1	178.6	297.5	535.4
538	7.9	20.7	41.4	62.1	103.4	172.4	310.3

**Table 2-3.5 Ratings for Group 3.5 Materials (Cont'd)**

<b>B — Special Class</b>							
<b>Temperature, °C</b>	<b>Working Pressures by Class, bar</b>						
	<b>150</b>	<b>300</b>	<b>600</b>	<b>900</b>	<b>1500</b>	<b>2500</b>	<b>4500</b>
550	6.7	17.4	34.9	52.3	87.2	145.3	261.5
575	4.5	11.8	23.6	35.4	59.0	98.3	176.9
600	3.2	8.3	16.6	24.9	41.5	69.1	124.5
625	2.5	6.4	12.8	19.3	32.1	53.5	96.3
650	2.3	5.9	11.8	17.7	29.5	49.2	88.6

## NOTES:

- (1) Only use annealed material.  
(2) Flanged-end valve ratings terminate at 538°C.

**Table 2-3.6 Ratings for Group 3.6 Materials**

B163 Gr. N08800 (1)	B408 Gr. N08800 (1)		B409 Gr. N08800 (1)		B564 Gr. N08800 (1)		
<b>A — Standard Class</b>							
Temperature, °C	Working Pressures by Class, bar						
	150	300	600	900	1500	2500	4500
-29 to 38	19.0	49.6	99.3	148.9	248.2	413.7	744.6
50	18.7	48.8	97.6	146.4	244.0	406.7	732.1
100	17.5	45.6	91.2	136.9	228.1	380.1	684.3
150	15.8	44.0	88.0	132.0	219.9	366.6	659.8
200	13.8	42.8	85.6	128.4	214.0	356.7	642.0
250	12.1	41.7	83.5	125.2	208.7	347.9	626.1
300	10.2	40.8	81.6	122.5	204.1	340.2	612.3
325	9.3	40.3	80.6	120.9	201.6	336.0	604.7
350	8.4	39.8	79.5	119.3	198.8	331.3	596.4
375	7.4	38.9	77.6	116.5	194.1	323.2	581.8
400	6.5	36.5	73.3	109.8	183.1	304.9	548.5
425	5.5	35.2	70.0	105.1	175.1	291.6	524.7
450	4.6	33.7	67.7	101.4	169.0	281.8	507.0
475	3.7	31.7	63.4	95.1	158.2	263.9	474.8
500	2.8	28.2	56.5	84.7	140.9	235.0	423.0
538	1.4	25.2	50.0	75.2	125.5	208.9	375.8
550	1.4 (2)	25.0	49.8	74.8	124.9	208.0	374.2
575	1.4 (2)	24.0	47.9	71.8	119.7	199.5	359.1
600	1.4 (2)	21.6	42.9	64.2	107.0	178.5	321.4
625	1.4 (2)	18.3	36.6	54.9	91.2	152.0	273.8
650	1.4 (2)	14.1	28.1	42.5	70.7	117.7	211.7
675	1.4 (2)	10.3	20.5	30.8	51.3	85.6	154.0
700	1.4 (2)	5.6	11.1	16.7	27.8	46.3	83.4
725	1.4 (2)	4.0	8.1	12.1	20.1	33.6	60.4
750	1.2 (2)	3.0	6.1	9.1	15.1	25.2	45.4
775	0.9 (2)	2.5	4.9	7.4	12.4	20.6	37.1
800	0.8 (2)	2.2	4.3	6.5	10.8	18.0	32.3
816	0.7 (2)	1.9	3.8	5.7	9.5	15.8	28.4
<b>B — Special Class</b>							
Temperature, °C	Working Pressures by Class, bar						
	150	300	600	900	1500	2500	4500
-29 to 38	20.0	51.7	103.4	155.1	258.6	430.9	775.7
50	20.0	51.7	103.4	155.1	258.6	430.9	775.7
100	19.5	50.9	101.8	152.7	254.6	424.3	763.7
150	18.8	49.1	98.2	147.3	245.5	409.1	736.4
200	18.3	47.8	95.5	143.3	238.8	398.0	716.5
250	17.9	46.6	93.2	139.8	232.9	388.2	698.8
300	17.5	45.6	91.1	136.7	227.8	379.6	683.4
325	17.2	45.0	90.0	135.0	225.0	375.0	674.9

**Table 2-3.6 Ratings for Group 3.6 Materials (Cont'd)**

<b>B — Special Class</b>							
<b>Temperature, °C</b>	<b>Working Pressures by Class, bar</b>						
	<b>150</b>	<b>300</b>	<b>600</b>	<b>900</b>	<b>1500</b>	<b>2500</b>	<b>4500</b>
350	17.0	44.4	88.8	133.1	221.9	369.8	665.6
375	16.8	43.9	87.8	131.6	219.4	365.6	658.1
400	16.6	43.4	86.8	130.1	216.9	361.5	650.7
425	16.4	42.9	85.8	128.6	214.4	357.3	643.2
450	16.2	42.4	84.8	127.1	211.9	353.2	635.7
475	16.1	42.0	84.0	126.1	210.1	350.2	630.3
500	13.7	35.6	71.5	107.1	178.6	297.5	535.4
538	11.0	29.0	57.9	86.9	145.1	241.7	435.1
550	11.0	29.0	57.9	86.9	145.1	241.7	435.1
575	10.9	28.6	57.1	85.7	143.0	238.3	428.8
600	10.3	26.9	53.5	80.4	134.0	223.4	401.9
625	8.7	23.0	45.7	68.6	114.3	190.6	342.8
650	6.9	17.9	35.5	53.1	88.6	147.9	266.1
675	4.9	12.8	25.7	38.5	64.2	107.0	192.5
700	2.7	6.9	13.9	20.8	34.7	57.9	104.2
725	1.9	5.0	10.1	15.1	25.2	42.0	75.5
750	1.4	3.8	7.6	11.3	18.9	31.5	56.7
775	1.2	3.1	6.2	9.3	15.5	25.8	46.4
800	1.0	2.7	5.4	8.1	13.5	22.5	40.4
816	0.9	2.4	4.7	7.1	11.8	19.7	35.5

## NOTES:

(1) Only use annealed material.

(2) Flanged-end valve ratings terminate at 538°C.

**Table 2-3.7 Ratings for Group 3.7 Materials**

B333 Gr. N10665 (1)	B335 Gr. N10675 (1)	B564 Gr. N10665 (1)	B622 Gr. N10675 (1)				
B333 Gr. N10675 (1)	B462 Gr. N10665 (1)	B564 Gr. N10675 (1)					
B335 Gr. N10665 (1)	B462 Gr. N10675 (1)	B622 Gr. N10665 (1)					
<b>A — Standard Class</b>							
Temperature, °C	Working Pressures by Class, bar						
	150	300	600	900	1500	2500	4500
-29 to 38	20.0	51.7	103.4	155.1	258.6	430.9	775.7
50	19.5	51.7	103.4	155.1	258.6	430.9	775.7
100	17.7	51.5	103.0	154.6	257.6	429.4	773.0
150	15.8	50.3	100.3	150.6	250.8	418.2	752.8
200	13.8	48.6	97.2	145.8	243.4	405.4	729.8
250	12.1	46.3	92.7	139.0	231.8	386.2	694.8
300	10.2	42.9	85.7	128.6	214.4	357.1	642.6
325	9.3	41.4	82.6	124.0	206.6	344.3	619.6
350	8.4	40.3	80.4	120.7	201.1	335.3	603.3
375	7.4	38.9	77.6	116.5	194.1	323.2	581.8
400	6.5	36.5	73.3	109.8	183.1	304.9	548.5
425	5.5	35.2	70.0	105.1	175.1	291.6	524.7
<b>B — Special Class</b>							
Temperature, °C	Working Pressures by Class, bar						
	150	300	600	900	1500	2500	4500
-29 to 38	20.0	51.7	103.4	155.1	258.6	430.9	775.7
50	20.0	51.7	103.4	155.1	258.6	430.9	775.7
100	20.0	51.7	103.4	155.1	258.6	430.9	775.7
150	20.0	51.7	103.4	155.1	258.6	430.9	775.7
200	20.0	51.7	103.4	155.1	258.6	430.9	775.7
250	20.0	51.7	103.4	155.1	258.6	430.9	775.7
300	20.0	51.7	103.4	155.1	258.6	430.9	775.7
325	20.0	51.7	103.4	155.1	258.6	430.9	775.7
350	19.8	51.5	102.8	154.3	257.1	428.6	771.4
375	19.3	50.6	101.0	151.5	252.5	420.9	757.4
400	19.3	50.3	100.6	150.6	251.2	418.3	753.2
425	19.0	49.6	99.3	148.9	248.2	413.7	744.6

NOTE: (1) Only use solution annealed material.

**Table 2-3.8 Ratings for Group 3.8 Materials**

B333 Gr. N10001 (1), (2)	B446 Gr. N06625 (3), (4)	B564 Gr. N10276 (1), (5)	B575 Gr. N06455 (1), (2)
B335 Gr. N10001 (1), (2)	B462 Gr. N06022 (1), (5)	B573 Gr. N10003 (3)	B575 Gr. N10276 (1), (5)
B423 Gr. N08825 (3), (6)	B462 Gr. N06200 (1), (2)	B574 Gr. N06022 (1), (5)	B622 Gr. N06022 (1), (5)
B424 Gr. N08825 (3), (6)	B462 Gr. N10276 (1), (5)	B574 Gr. N06200 (1), (2)	B622 Gr. N06200 (1), (2)
B425 Gr. N08825 (3), (6)	B564 Gr. N06022 (1), (5)	B574 Gr. N06455 (1), (2)	B622 Gr. N06455 (1), (2)
B434 Gr. N10003 (3)	B564 Gr. N06200 (1), (2)	B574 Gr. N10276 (1), (5)	B622 Gr. N10001 (2), (3)
B443 Gr. N06625 (3), (4)	B564 Gr. N06625 (3), (4)	B575 Gr. N06022 (1), (5)	B622 Gr. N10276 (1), (5)
	B564 Gr. N08825 (3), (6)	B575 Gr. N06200 (1), (2)	

**A — Standard Class**

Temperature, °C	Working Pressures by Class, bar						
	150	300	600	900	1500	2500	4500
-29 to 38	20.0	51.7	103.4	155.1	258.6	430.9	775.7
50	19.5	51.7	103.4	155.1	258.6	430.9	775.7
100	17.7	51.5	103.0	154.6	257.6	429.4	773.0
150	15.8	50.3	100.3	150.6	250.8	418.2	752.8
200	13.8	48.3	96.7	145.0	241.7	402.8	725.1
250	12.1	46.3	92.7	139.0	231.8	386.2	694.8
300	10.2	42.9	85.7	128.6	214.4	357.1	642.6
325	9.3	41.4	82.6	124.0	206.6	344.3	619.6
350	8.4	40.3	80.4	120.7	201.1	335.3	603.3
375	7.4	38.9	77.6	116.5	194.1	323.2	581.8
400	6.5	36.5	73.3	109.8	183.1	304.9	548.5
425	5.5	35.2	70.0	105.1	175.1	291.6	524.7
450	4.6	33.7	67.7	101.4	169.0	281.8	507.0
475	3.7	31.7	63.4	95.1	158.2	263.9	474.8
500	2.8	28.2	56.5	84.7	140.9	235.0	423.0
538	1.4	25.2	50.0	75.2	125.5	208.9	375.8
550	1.4 (7)	25.0	49.8	74.8	124.9	208.0	374.2
575	1.4 (7)	24.0	47.9	71.8	119.7	199.5	359.1
600	1.4 (7)	21.6	42.9	64.2	107.0	178.5	321.4
625	1.4 (7)	18.3	36.6	54.9	91.2	152.0	273.8
650	1.4 (7)	14.1	28.1	42.2	70.4	117.3	211.1
675	1.4 (7)	11.5	23.0	34.6	57.6	96.0	172.8
700	1.4 (7)	8.8	17.5	26.3	43.8	73.0	131.5

**B — Special Class**

Temperature, °C	Working Pressures by Class, bar						
	150	300	600	900	1500	2500	4500
-29 to 38	20.0	51.7	103.4	155.1	258.6	430.9	775.7
50	20.0	51.7	103.4	155.1	258.6	430.9	775.7
100	20.0	51.7	103.4	155.1	258.6	430.9	775.7
150	20.0	51.7	103.4	155.1	258.6	430.9	775.7
200	20.0	51.7	103.4	155.1	258.6	430.9	775.7
250	19.8	51.7	103.4	155.1	258.6	430.9	775.7
300	19.1	49.9	99.8	149.6	249.4	415.7	748.2
325	18.8	49.1	98.1	147.2	245.3	408.8	735.9

**Table 2-3.8 Ratings for Group 3.8 Materials (Cont'd)**

<b>B — Special Class</b>							
<b>Temperature, °C</b>	<b>Working Pressures by Class, bar</b>						
	<b>150</b>	<b>300</b>	<b>600</b>	<b>900</b>	<b>1500</b>	<b>2500</b>	<b>4500</b>
350	18.6	48.4	96.9	145.3	242.2	403.7	726.6
375	18.4	47.9	95.9	143.8	239.7	399.5	719.1
400	18.2	47.5	94.9	142.4	237.3	395.5	711.8
425	18.1	47.3	94.6	141.9	236.4	394.1	709.3
450	17.9	46.8	93.6	140.4	234.1	390.1	702.2
475	16.4	42.8	85.5	128.2	213.7	356.3	641.3
500	13.7	35.6	71.5	107.1	178.6	297.5	535.4
538	11.0	29.0	57.9	86.9	145.1	241.7	435.1
550	11.0	29.0	57.9	86.9	145.1	241.7	435.1
575	10.9	28.6	57.1	85.7	143.0	238.3	428.8
600	10.3	26.9	53.5	80.4	134.0	223.4	401.9
625	8.7	23.0	45.7	68.6	114.3	190.6	342.8
650	6.7	17.6	35.2	52.8	87.9	146.6	263.8
675	5.5	14.4	28.8	43.2	72.0	120.0	215.9
700	4.2	11.0	21.9	32.9	54.8	91.3	164.4

## NOTES:

- (1) Only use solution annealed material.
- (2) Not to be used over 425°C.
- (3) Only use annealed material.
- (4) Not to be used over 645°C. Alloy N06625 in the annealed condition is subject to severe loss of impact strength at room temperatures after exposure in the range of 538°C to 760°C.
- (5) Not to be used over 675°C.
- (6) Not to be used over 538°C.
- (7) Flanged-end valve ratings terminate at 538°C.



**Table 2-3.9 Ratings for Group 3.9 Materials**

B435 Gr. N06002 (1)		B572 Gr. N06002 (1)		B622 Gr. N06002 (1)		B622 Gr. R30556 (1)	
B435 Gr. R30556 (1)		B572 Gr. R30556 (1)					
<b>A — Standard Class</b>							
Temperature, °C	Working Pressures by Class, bar						
	150	300	600	900	1500	2500	4500
-29 to 38	20.0	51.7	103.4	155.1	258.6	430.9	775.7
50	19.5	51.7	103.4	155.1	258.6	430.9	775.7
100	17.7	51.5	103.0	154.6	257.6	429.4	773.0
150	15.8	47.6	95.2	142.8	237.9	396.5	713.8
200	13.8	44.3	88.6	132.9	221.5	369.2	664.6
250	12.1	41.6	83.1	124.7	207.9	346.4	623.6
300	10.2	39.5	79.0	118.5	197.4	329.1	592.3
325	9.3	38.6	77.2	115.8	193.0	321.7	579.1
350	8.4	37.9	75.8	113.7	189.5	315.8	568.5
375	7.4	37.3	74.7	112.0	186.6	311.1	559.9
400	6.5	36.5	73.3	109.8	183.1	304.9	548.5
425	5.5	35.2	70.0	105.1	175.1	291.6	524.7
450	4.6	33.7	67.7	101.4	169.0	281.8	507.0
475	3.7	31.7	63.4	95.1	158.2	263.9	474.8
500	2.8	28.2	56.5	84.7	140.9	235.0	423.0
538	1.4	25.2	50.0	75.2	125.5	208.9	375.8
550	1.4 (2)	25.0	49.8	74.8	124.9	208.0	374.2
575	1.4 (2)	24.0	47.9	71.8	119.7	199.5	359.1
600	1.4 (2)	21.6	42.9	64.2	107.0	178.5	321.4
625	1.4 (2)	18.3	36.6	54.9	91.2	152.0	273.8
650	1.4 (2)	14.1	28.1	42.5	70.7	117.7	211.7
675	1.4 (2)	12.4	25.2	37.6	62.7	104.5	187.9
700	1.4 (2)	10.1	20.0	29.8	49.7	83.0	149.4
725	1.4 (2)	7.9	15.4	23.2	38.6	64.4	115.8
750	1.4 (2)	5.9	11.7	17.6	29.6	49.1	88.2
775	1.4 (2)	4.6	9.0	13.7	22.8	38.0	68.4
800	1.2 (2)	3.5	7.0	10.5	17.4	29.2	52.6
816	1.0 (2)	2.8	5.9	8.6	14.1	23.8	42.7
<b>B — Special Class</b>							
Temperature, °C	Working Pressures by Class, bar						
	150	300	600	900	1500	2500	4500
-29 to 38	20.0	51.7	103.4	155.1	258.6	430.9	775.7
50	20.0	51.7	103.4	155.1	258.6	430.9	775.7
100	20.0	51.7	103.4	155.1	258.6	430.9	775.7
150	20.0	51.7	103.4	155.1	258.6	430.9	775.7
200	19.0	49.5	98.9	148.4	247.3	412.1	741.8
250	17.8	46.4	92.8	139.2	232.0	386.7	696.0
300	16.9	44.1	88.1	132.2	220.4	367.3	661.1
325	16.5	43.1	86.2	129.3	215.4	359.1	646.3

**Table 2-3.9 Ratings for Group 3.9 Materials (Cont'd)**

<b>B — Special Class</b>							
<b>Temperature, °C</b>	<b>Working Pressures by Class, bar</b>						
	<b>150</b>	<b>300</b>	<b>600</b>	<b>900</b>	<b>1500</b>	<b>2500</b>	<b>4500</b>
350	16.2	42.3	84.6	126.9	211.5	352.5	634.5
375	16.0	41.7	83.3	125.0	208.3	347.2	624.9
400	15.8	41.2	82.3	123.5	205.8	343.1	617.5
425	15.7	40.8	81.7	122.5	204.2	340.3	612.5
450	15.5	40.5	81.0	121.5	202.5	337.5	607.6
475	15.4	40.2	80.3	120.5	200.9	334.8	602.6
500	13.7	35.6	71.5	107.1	178.6	297.5	535.4
538	11.0	29.0	57.9	86.9	145.1	241.7	435.1
550	11.0	29.0	57.9	86.9	145.1	241.7	435.1
575	10.9	28.6	57.1	85.7	143.0	238.3	428.8
600	10.3	26.9	53.5	80.4	134.0	223.4	401.9
625	8.7	23.0	45.7	68.6	114.3	190.6	342.8
650	6.9	17.9	35.5	53.1	88.6	147.9	266.1
675	6.2	16.0	31.6	47.3	78.9	131.7	237.0
700	4.8	12.4	25.0	37.3	62.3	103.7	186.5
725	3.7	9.7	19.5	28.9	48.3	80.2	144.5
750	2.8	7.4	14.8	22.1	36.7	61.2	110.3
775	2.2	5.8	11.4	17.2	28.5	47.6	85.6
800	1.8	4.4	8.8	13.2	22.0	36.6	65.6
816	1.4	3.4	7.2	10.7	17.9	29.6	53.1

## NOTES:

- (1) Only use solution annealed material.  
(2) Flanged-end valve ratings terminate at 538°C.

**Table 2-3.10 Ratings for Group 3.10 Materials**

B599 Gr. N08700 (1)		B672 Gr. N08700 (1)					
<b>A — Standard Class</b>							
Temperature, °C	Working Pressures by Class, bar						
	150	300	600	900	1500	2500	4500
-29 to 38	20.0	51.7	103.4	155.1	258.6	430.9	775.7
50	19.5	51.7	103.4	155.1	258.6	430.9	775.7
100	17.7	51.5	103.0	154.6	257.6	429.4	772.9
150	15.8	47.1	94.2	141.3	235.5	392.5	706.5
200	13.8	44.3	88.5	132.8	221.3	368.9	664.0
250	12.1	42.8	85.6	128.4	214.0	356.6	641.9
300	10.2	41.3	82.7	124.0	206.7	344.5	620.0
325	9.3	40.4	80.7	121.1	201.8	336.4	605.5
350	8.4	38.9	77.8	116.7	194.5	324.2	583.6
<b>B — Special Class</b>							
Temperature, °C	Working Pressures by Class, bar						
	150	300	600	900	1500	2500	4500
-29 to 38	20.0	51.7	103.4	155.1	258.6	430.9	775.7
50	20.0	51.7	103.4	155.1	258.6	430.9	775.7
100	20.0	51.7	103.4	155.1	258.6	430.9	775.7
150	20.0	51.7	103.4	155.1	258.6	430.9	775.7
200	18.9	49.4	98.8	148.2	247.0	411.7	741.1
250	18.3	47.8	95.5	143.3	238.8	398.0	716.4
300	17.7	46.1	92.3	138.4	230.7	384.4	692.0
325	17.3	45.1	90.1	135.2	225.3	375.4	675.8
350	16.6	43.4	86.9	130.3	217.1	361.9	651.4

NOTE: (1) Only use solution annealed material.

**Table 2-3.11 Ratings for Group 3.11 Materials**

B625 Gr. N08904 (1)	B649 Gr. N08904 (1)		B677 Gr. N08904 (1)				
<b>A — Standard Class</b>							
Temperature, °C	Working Pressures by Class, bar						
	150	300	600	900	1500	2500	4500
-29 to 38	19.7	51.3	102.6	153.9	256.5	427.5	769.5
50	18.8	49.1	98.3	147.4	245.7	409.6	737.2
100	15.7	41.1	82.1	123.2	205.3	342.1	615.9
150	14.4	37.5	75.0	112.5	187.5	312.5	562.5
200	13.3	34.7	69.3	104.0	173.4	288.9	520.1
250	12.1	32.0	64.0	95.9	159.9	266.5	479.6
300	10.2	30.0	60.0	90.0	150.1	250.1	450.2
325	9.3	29.2	58.5	87.7	146.1	243.6	438.4
350	8.4	28.7	57.3	86.0	143.4	238.9	430.1
375	7.4	28.2	56.5	84.7	141.2	235.4	423.7
<b>B — Special Class</b>							
Temperature, °C	Working Pressures by Class, bar						
	150	300	600	900	1500	2500	4500
-29 to 38	20.0	51.7	103.4	155.1	258.6	430.9	775.7
50	19.6	51.1	102.2	153.3	255.5	425.9	766.6
100	17.6	45.8	91.6	137.5	229.1	381.9	687.3
150	16.0	41.9	83.7	125.6	209.3	348.8	627.8
200	14.8	38.7	77.4	116.1	193.5	322.5	580.4
250	13.7	35.7	71.4	107.1	178.4	297.4	535.3
300	12.8	33.5	67.0	100.5	167.5	279.1	502.4
325	12.5	32.6	65.2	97.9	163.1	271.9	489.3
350	12.3	32.0	64.0	96.0	160.0	266.7	480.0
375	12.1	31.5	63.1	94.6	157.6	262.7	472.9

NOTE: (1) Only use annealed material.

**Table 2-3.12 Ratings for Group 3.12 Materials**

A351 Gr. CN3MN (1)	B574 Gr. N06035 (1), (2)	B620 Gr. N08320 (1)	B622 Gr. N08320 (1)
B462 Gr. N06035 (1), (2)	B575 Gr. N06035 (1), (2)	B621 Gr. N08320 (1)	B688 Gr. N08367 (1)
B462 Gr. N08367 (1)	B581 Gr. N06985 (1)	B622 Gr. N06035 (1), (2)	B691 Gr. N08367 (1), (2)
B564 Gr. N06035 (1), (2)	B582 Gr. N06985 (1)	B622 Gr. N06985 (1)	

**A — Standard Class**

Temperature, °C	Working Pressures by Class, bar						
	150	300	600	900	1500	2500	4500
-29 to 38	17.8	46.3	92.7	139.0	231.7	386.1	695.0
50	17.5	45.6	91.1	136.7	227.8	379.7	683.5
100	16.3	42.5	85.1	127.6	212.7	354.5	638.1
150	15.4	40.1	80.3	120.4	200.7	334.6	602.2
200	13.8	37.3	74.6	112.0	186.6	311.0	559.8
250	12.1	34.9	69.8	104.7	174.5	290.8	523.4
300	10.2	33.1	66.2	99.3	165.5	275.9	496.6
325	9.3	32.3	64.6	97.0	161.6	269.3	484.8
350	8.4	31.6	63.2	94.8	158.1	263.4	474.2
375	7.4	31.0	62.0	93.0	155.1	258.5	465.2
400	6.5	30.4	60.8	91.3	152.1	253.5	456.3
425	5.5	29.8	59.7	89.5	149.1	248.5	447.4

**B — Special Class**

Temperature, °C	Working Pressures by Class, bar						
	150	300	600	900	1500	2500	4500
-29 to 38	19.8	51.7	103.4	155.1	258.6	430.9	775.7
50	19.5	50.9	101.7	152.6	254.3	423.8	762.9
100	18.2	47.5	95.0	142.4	237.4	395.6	712.2
150	17.2	44.8	89.6	134.4	224.0	373.4	672.1
200	16.0	41.6	83.3	124.9	208.2	347.1	624.7
250	14.9	38.9	77.9	116.8	194.7	324.5	584.2
300	14.2	37.0	73.9	110.9	184.8	307.9	554.3
325	13.8	36.1	72.1	108.2	180.3	300.6	541.0
350	13.5	35.3	70.6	105.8	176.4	294.0	529.2
375	13.3	34.6	69.2	103.8	173.1	288.5	519.2
400	13.0	34.0	67.9	101.9	169.8	282.9	509.3
425	12.8	33.3	66.6	99.9	166.4	277.4	499.3

NOTES:

- (1) Only use solution annealed material.
- (2) Not to be used over 425°C.

**Table 2-3.13 Ratings for Group 3.13 Materials**

		B582 Gr. N06975 (2)		B622 Gr. N08031 (1)		B649 Gr. N08031 (1)	
		B622 Gr. N06975 (2)		B625 Gr. N08031 (1)			
<b>A — Standard Class</b>							
Temperature, °C	Working Pressures by Class, bar						
	150	300	600	900	1500	2500	4500
-29 to 38	20.0	51.7	103.4	155.1	258.6	430.9	775.7
50	19.5	51.7	103.4	155.1	258.6	430.9	775.7
100	17.7	48.2	96.3	144.5	240.8	401.4	722.5
150	15.8	45.8	91.6	137.4	228.9	381.6	686.8
200	13.8	43.6	87.1	130.7	217.8	362.9	653.3
250	12.1	41.5	82.9	124.4	207.3	345.5	621.8
300	10.2	39.4	78.7	118.1	196.8	328.1	590.5
325	9.3	38.4	76.9	115.3	192.2	320.3	576.6
350	8.4	37.7	75.5	113.2	188.7	314.5	566.0
375	7.4	37.2	74.3	111.5	185.8	309.7	557.4
400	6.5	36.5	73.3	109.8	183.1	304.9	548.5
425	5.5	35.2	70.0	105.1	175.1	291.6	524.7
<b>B — Special Class</b>							
Temperature, °C	Working Pressures by Class, bar						
	150	300	600	900	1500	2500	4500
-29 to 38	20.0	51.7	103.4	155.1	258.6	430.9	775.7
50	20.0	51.7	103.4	155.1	258.6	430.9	775.7
100	20.0	51.7	103.4	155.1	258.6	430.9	775.7
150	19.6	51.1	102.2	153.3	255.5	425.8	766.5
200	18.6	48.6	97.2	145.8	243.0	405.1	729.1
250	17.7	46.3	92.5	138.8	231.3	385.6	694.0
300	16.8	43.9	87.9	131.8	219.7	366.2	659.1
325	16.4	42.9	85.8	128.7	214.5	357.5	643.5
350	16.1	42.1	84.2	126.3	210.6	351.0	631.7
375	15.9	41.5	83.0	124.4	207.4	345.6	622.1
400	15.7	41.0	82.0	123.0	204.9	341.5	614.8
425	15.6	40.7	81.3	122.0	203.3	338.8	609.8

## NOTES:

(1) Only use annealed material.

(2) Only use solution annealed material.

**Table 2-3.14 Ratings for Group 3.14 Materials**

B462 Gr. N06030 (1), (2)	B581 Gr. N06030 (1), (2)	B582 Gr. N06030 (1), (2)	B622 Gr. N06030 (1), (2)
B581 Gr. N06007 (1)	B582 Gr. N06007 (1)	B622 Gr. N06007 (1)	

**A — Standard Class**

Temperature, °C	Working Pressures by Class, bar						
	150	300	600	900	1500	2500	4500
-29 to 38	19.0	49.6	99.3	148.9	248.2	413.7	744.6
50	18.6	48.6	97.1	145.7	242.8	404.6	728.3
100	17.0	44.3	88.6	132.8	221.4	369.0	664.2
150	15.8	41.3	82.6	124.0	206.6	344.3	619.8
200	13.8	39.1	78.2	117.3	195.4	325.7	586.3
250	12.1	37.4	74.8	112.2	187.0	311.6	560.9
300	10.2	36.1	72.2	108.3	180.6	300.9	541.7
325	9.3	35.6	71.1	106.7	177.9	296.4	533.6
350	8.4	35.2	70.3	105.5	175.8	293.1	527.5
375	7.4	34.9	69.7	104.6	174.3	290.6	523.0
400	6.5	34.6	69.2	103.7	172.9	288.1	518.7
425	5.5	34.4	68.9	103.3	172.1	286.9	516.4
450	4.6	33.7	67.7	101.4	169.0	281.8	507.0
475	3.7	31.7	63.4	95.1	158.2	263.9	474.8
500	2.8	28.2	56.5	84.7	140.9	235.0	423.0
538	1.4	25.2	50.0	75.2	125.5	208.9	375.8

**B — Special Class**

Temperature, °C	Working Pressures by Class, bar						
	150	300	600	900	1500	2500	4500
-29 to 38	20.0	51.7	103.4	155.1	258.6	430.9	775.7
50	20.0	51.7	103.4	155.1	258.6	430.9	775.7
100	18.9	49.4	98.8	148.3	247.1	411.8	741.3
150	17.7	46.1	92.2	138.3	230.6	384.3	691.7
200	16.7	43.6	87.2	130.9	218.1	363.5	654.3
250	16.0	41.7	83.5	125.2	208.7	347.8	626.0
300	15.5	40.3	80.6	120.9	201.5	335.9	604.6
325	15.2	39.7	79.4	119.1	198.5	330.9	595.5
350	15.0	39.2	78.5	117.7	196.2	327.1	588.7
375	14.9	38.9	77.8	116.7	194.6	324.3	583.7
400	14.8	38.6	77.2	115.8	193.0	321.6	578.9
425	14.7	38.4	76.8	115.3	192.1	320.2	576.4
450	14.7	38.3	76.5	114.8	191.3	318.8	573.9
475	14.6	38.1	76.2	114.3	190.5	317.4	571.4
500	13.7	35.6	71.5	107.1	178.6	297.5	535.4
538	11.0	29.0	57.9	86.9	145.1	241.7	435.1

NOTES:

- (1) Only use solution annealed material.
- (2) Not to be used over 425°C.

Table 2-3.15 Ratings for Group 3.15 Materials

A494 Gr. N-12MV (1), (2)		B407 Gr. N08810 (1)		B409 Gr. N08810 (1)		B564 Gr. N08810 (1)	
A494 Gr. CW-12MW (1), (2)		B408 Gr. N08810 (1)					
A — Standard Class							
Temperature, °C	Working Pressures by Class, bar						
	150	300	600	900	1500	2500	4500
-29 to 38	15.9	41.4	82.7	124.1	206.8	344.7	620.5
50	15.6	40.6	81.3	121.9	203.2	338.7	609.6
100	14.5	37.8	75.6	113.4	189.0	315.0	567.0
150	13.7	35.9	71.7	107.6	179.3	298.9	538.0
200	13.0	33.9	67.9	101.8	169.6	282.7	508.9
250	12.1	32.3	64.5	96.8	161.3	268.9	484.0
300	10.2	30.7	61.5	92.2	153.7	256.2	461.2
325	9.3	30.1	60.1	90.2	150.3	250.5	450.9
350	8.4	29.4	58.8	88.3	147.1	245.2	441.3
375	7.4	28.7	57.4	86.2	143.6	239.4	430.8
400	6.5	28.3	56.5	84.8	141.3	235.6	424.0
425	5.5	27.7	55.3	83.0	138.4	230.6	415.1
450	4.6	27.2	54.4	81.7	136.1	226.8	408.3
475	3.7	26.8	53.5	80.3	133.9	223.1	401.6
500	2.8	26.3	52.6	79.0	131.6	219.4	394.9
538	1.4	25.2	50.0	75.2	125.5	208.9	375.8
550	1.4 (3)	25.0	49.8	74.8	124.9	208.0	374.2
575	1.4 (3)	24.0	47.9	71.8	119.7	199.5	359.1
600	1.4 (3)	21.6	42.9	64.2	107.0	178.5	321.4
625	1.4 (3)	18.3	36.6	54.9	91.2	152.0	273.8
650	1.4 (3)	14.1	28.1	42.5	70.7	117.7	211.7
675	1.4 (3)	12.4	25.2	37.6	62.7	104.5	187.9
700	1.4 (3)	10.1	20.0	29.8	49.7	83.0	149.4
725	1.4 (3)	7.9	15.4	23.2	38.6	64.4	115.8
750	1.4 (3)	5.9	11.7	17.6	29.6	49.1	88.2
775	1.4 (3)	4.6	9.0	13.7	22.8	38.0	68.4
800	1.2 (3)	3.5	7.0	10.5	17.4	29.2	52.6
816	1.0 (3)	2.8	5.9	8.6	14.1	23.8	42.7
B — Special Class							
Temperature, °C	Working Pressures by Class, bar						
	150	300	600	900	1500	2500	4500
-29 to 38	17.7	46.2	92.3	138.5	230.9	384.8	692.6
50	17.4	45.4	90.7	136.1	226.8	378.0	680.4
100	16.2	42.2	84.4	126.6	210.9	351.6	632.8
150	15.3	40.0	80.1	120.1	200.1	333.6	600.4
200	14.5	37.9	75.7	113.6	189.3	315.6	568.0
250	13.8	36.0	72.0	108.0	180.0	300.1	540.1
300	13.2	34.3	68.6	102.9	171.6	285.9	514.7
325	12.9	33.5	67.1	100.6	167.7	279.5	503.2



**Table 2-3.15 Ratings for Group 3.15 Materials (Cont'd)**

<b>B — Special Class</b>							
<b>Temperature, °C</b>	<b>Working Pressures by Class, bar</b>						
	<b>150</b>	<b>300</b>	<b>600</b>	<b>900</b>	<b>1500</b>	<b>2500</b>	<b>4500</b>
350	12.6	32.8	65.7	98.5	164.2	273.6	492.5
375	12.3	32.1	64.1	96.2	160.3	267.1	480.9
400	12.1	31.6	63.1	94.7	157.8	262.9	473.3
425	11.8	30.9	61.8	92.7	154.4	257.4	463.3
450	11.6	30.4	60.8	91.1	151.9	253.1	455.6
475	11.5	29.9	59.8	89.6	149.4	249.0	448.2
500	11.3	29.4	58.8	88.1	146.9	244.8	440.7
538	11.0	28.6	57.3	85.9	143.1	238.5	429.4
550	11.0	28.6	57.3	85.9	143.1	238.5	429.4
575	10.9	28.6	57.1	85.7	143.0	238.3	428.8
600	10.3	26.9	53.5	80.4	134.0	223.4	401.9
625	8.7	23.0	45.7	68.6	114.3	190.6	342.8
650	6.9	17.9	35.5	53.1	88.6	147.9	266.1
675	6.2	16.0	31.6	47.3	78.9	131.7	237.0
700	4.8	12.4	25.0	37.3	62.3	103.7	186.5
725	3.7	9.7	19.5	28.9	48.3	80.2	144.5
750	2.8	7.4	14.8	22.1	36.7	61.2	110.3
775	2.2	5.8	11.4	17.2	28.5	47.6	85.6
800	1.8	4.4	8.8	13.2	22.0	36.6	65.6
816	1.4	3.4	7.2	10.7	17.9	29.6	53.1

## NOTES:

- (1) Only use solution annealed material.
- (2) Not to be used over 538°C.
- (3) Flanged-end valve ratings terminate at 538°C.

Table 2-3.16 Ratings for Group 3.16 Materials

B511 Gr. N08330 (1)	B535 Gr. N08330 (1)		B536 Gr. N08330 (1)				
A — Standard Class							
Temperature, °C	Working Pressures by Class, bar						
	150	300	600	900	1500	2500	4500
-29 to 38	19.0	49.6	99.3	148.9	248.2	413.7	744.6
50	18.5	48.4	96.7	145.1	241.8	403.1	725.5
100	16.7	43.5	87.0	130.5	217.5	362.4	652.4
150	15.6	40.8	81.6	122.5	204.1	340.2	612.3
200	13.8	38.6	77.2	115.8	192.9	321.6	578.8
250	12.1	36.8	73.5	110.3	183.8	306.3	551.4
300	10.2	35.2	70.4	105.6	176.1	293.4	528.2
325	9.3	34.5	69.0	103.6	172.6	287.7	517.9
350	8.4	33.9	67.8	101.7	169.4	282.4	508.3
375	7.4	33.2	66.3	99.5	165.8	276.4	497.5
400	6.5	32.6	65.1	97.7	162.9	271.4	488.6
425	5.5	32.0	64.0	95.9	159.9	266.5	479.6
450	4.6	31.4	62.8	94.1	156.9	261.5	470.7
475	3.7	30.8	61.6	92.4	153.9	256.5	461.8
500	2.8	28.2	56.5	84.7	140.9	235.0	423.0
538	1.4	25.2	50.0	75.2	125.5	208.9	375.8
550	1.4 (2)	25.0	49.8	74.8	124.9	208.0	374.2
575	1.4 (2)	21.9	43.7	65.6	109.4	182.3	328.1
600	1.4 (2)	17.4	34.8	52.3	87.1	145.1	261.3
625	1.4 (2)	13.8	27.5	41.3	68.8	114.6	206.3
650	1.4 (2)	11.0	22.1	33.1	55.1	91.9	165.4
675	1.4 (2)	9.1	18.2	27.3	45.6	75.9	136.7
700	1.4 (2)	7.6	15.2	22.8	38.0	63.3	113.9
725	1.4 (2)	6.1	12.2	18.3	30.5	50.9	91.6
750	1.4 (2)	4.8	9.5	14.3	23.8	39.7	71.5
775	1.4 (2)	3.9	7.7	11.6	19.4	32.3	58.1
800	1.2 (2)	3.1	6.3	9.4	15.6	26.1	46.9
816	1.0 (2)	2.6	5.2	7.8	13.0	21.7	39.0
B — Special Class							
Temperature, °C	Working Pressures by Class, bar						
	150	300	600	900	1500	2500	4500
-29 to 38	19.8	51.7	103.4	155.1	258.6	430.9	775.7
50	19.6	51.1	102.2	153.3	255.5	425.8	766.5
100	18.6	48.5	97.1	145.6	242.7	404.5	728.1
150	17.5	45.6	91.1	136.7	227.8	379.7	683.4
200	16.5	43.1	86.1	129.2	215.3	358.9	646.0
250	15.7	41.0	82.1	123.1	205.1	341.9	615.4
300	15.1	39.3	78.6	117.9	196.5	327.5	589.5
325	14.8	38.5	77.1	115.6	192.7	321.1	578.0

**Table 2-3.16 Ratings for Group 3.16 Materials (Cont'd)**

<b>B — Special Class</b>							
<b>Temperature, °C</b>	<b>Working Pressures by Class, bar</b>						
	<b>150</b>	<b>300</b>	<b>600</b>	<b>900</b>	<b>1500</b>	<b>2500</b>	<b>4500</b>
350	14.5	37.8	75.6	113.5	189.1	315.2	567.3
375	14.2	37.0	74.0	111.1	185.1	308.5	555.3
400	13.9	36.4	72.7	109.1	181.8	302.9	545.3
425	13.7	35.7	71.4	107.1	178.4	297.4	535.3
450	13.4	35.0	70.0	105.1	175.1	291.9	525.3
475	13.2	34.4	68.7	103.1	171.8	286.3	515.4
500	13.0	33.8	67.6	101.4	169.1	281.8	507.2
538	11.0	29.0	57.9	86.9	145.1	241.7	435.1
550	11.0	29.0	57.9	86.9	145.1	241.7	435.1
575	10.5	27.3	54.7	82.0	136.7	227.8	410.1
600	8.3	21.8	43.5	65.3	108.9	181.4	326.6
625	6.6	17.2	34.4	51.6	86.0	143.3	257.9
650	5.3	13.8	27.6	41.3	68.9	114.8	206.7
675	4.4	11.4	22.8	34.2	56.9	94.9	170.8
700	3.6	9.5	19.0	28.5	47.5	79.1	142.4
725	2.9	7.6	15.3	22.9	38.1	63.6	114.4
750	2.3	6.0	11.9	17.9	29.8	49.6	89.4
775	1.9	4.8	9.7	14.5	24.2	40.3	72.6
800	1.5	3.9	7.8	11.7	19.6	32.6	58.7
816	1.2	3.3	6.5	9.8	16.3	27.1	48.8

## NOTES:

- (1) Only use solution annealed material.  
(2) Flanged-end valve ratings terminate at 538°C.

**Table 2-3.17 Ratings for Group 3.17 Materials**

A351 Gr. CN7M (1)

<b>A — Standard Class</b>							
<b>Temperature, °C</b>	<b>Working Pressures by Class, bar</b>						
	<b>150</b>	<b>300</b>	<b>600</b>	<b>900</b>	<b>1500</b>	<b>2500</b>	<b>4500</b>
-29 to 38	15.9	41.4	82.7	124.1	206.8	344.7	620.5
50	15.4	40.1	80.3	120.4	200.7	334.4	602.0
100	13.5	35.3	70.6	105.9	176.5	294.2	529.6
150	12.3	32.0	64.1	96.1	160.2	267.0	480.6
200	11.3	29.4	58.7	88.1	146.8	244.7	440.4
250	10.4	27.2	54.4	81.7	136.1	226.9	408.4
300	9.7	25.4	50.8	76.1	126.9	211.5	380.7
325	9.3	24.4	48.8	73.3	122.1	203.5	366.4
<b>B — Special Class</b>							
<b>Temperature, °C</b>	<b>Working Pressures by Class, bar</b>						
	<b>150</b>	<b>300</b>	<b>600</b>	<b>900</b>	<b>1500</b>	<b>2500</b>	<b>4500</b>
-29 to 38	17.6	45.8	91.6	137.4	229.0	381.7	687.0
50	17.0	44.2	88.5	132.7	221.2	368.7	663.6
100	14.7	38.3	76.6	114.9	191.5	319.1	574.4
150	13.5	35.2	70.4	105.5	175.9	293.2	527.7
200	12.5	32.7	65.4	98.2	163.6	272.7	490.8
250	11.6	30.4	60.8	91.2	151.9	253.2	455.8
300	10.9	28.3	56.6	85.0	141.6	236.0	424.8
325	10.5	27.3	54.5	81.8	136.3	227.2	408.9

NOTE: (1) Only use solution annealed material.

Table 2-3.18 Ratings for Group 3.18 Materials

B167 Gr. N06600 (1)							
A — Standard Class							
Temperature, °C	Working Pressures by Class, bar						
	150	300	600	900	1500	2500	4500
-29 to 38	19.0	49.6	99.3	148.9	248.2	413.7	744.6
50	18.8	49.1	98.3	147.4	245.7	409.4	737.0
100	17.7	47.1	94.2	141.3	235.4	392.4	706.3
150	15.8	45.3	90.6	135.9	226.5	377.5	679.5
200	14.0	43.5	87.0	130.5	217.6	362.6	652.7
250	12.1	42.0	84.0	126.0	210.0	350.0	630.0
300	10.2	40.6	81.3	121.9	203.1	338.6	609.4
325	9.1	40.0	80.0	120.0	199.9	333.2	599.8
350	8.4	39.4	78.8	118.2	196.9	328.2	590.8
375	7.4	38.8	77.6	116.4	194.0	323.4	582.1
400	6.5	36.6	73.2	109.8	182.9	304.9	548.8
425	5.6	35.1	70.2	105.3	175.5	292.5	526.4
450	4.7	33.8	67.6	101.4	169.0	281.7	507.1
475	3.7	31.7	63.3	95.0	158.3	263.8	474.8
500	2.8	28.2	56.4	84.6	141.0	235.1	423.1
538	1.4	16.5	33.1	49.6	82.7	137.9	248.2
550	1.4 (2)	13.9	27.9	41.8	69.7	116.2	209.2
575	1.4 (2)	9.4	18.9	28.3	47.2	78.6	141.5
600	1.4 (2)	6.6	13.3	19.9	33.2	55.3	99.6
625	1.4 (2)	5.1	10.3	15.4	25.7	42.8	77.0
650	1.4 (2)	4.7	9.5	14.2	23.6	39.4	70.9
B — Special Class							
Temperature, °C	Working Pressures by Class, bar						
	150	300	600	900	1500	2500	4500
-29 to 38	20.0	51.7	103.5	155.2	258.6	431.1	775.9
50	20.0	51.7	103.5	155.2	258.6	431.1	775.9
100	20.0	51.7	103.5	155.2	258.6	431.1	775.9
150	19.4	50.6	101.1	151.7	252.8	421.3	758.4
200	18.6	48.6	97.1	145.7	242.8	404.7	728.5
250	18.0	46.9	93.7	140.6	234.4	390.6	703.1
300	17.4	45.3	90.7	136.0	226.7	377.9	680.1
325	17.1	44.6	89.3	133.9	223.1	371.9	669.4
350	16.9	44.0	87.9	131.9	201.2	366.3	659.4
375	16.6	43.3	86.6	130.0	194.0	361.0	649.8
400	16.4	42.8	85.6	128.5	182.9	356.9	642.4
425	16.2	42.3	84.7	127.0	175.5	352.7	634.9
450	16.0	41.8	83.7	125.5	169.0	348.6	627.4
475	15.8	41.3	82.7	124.0	158.3	344.4	619.9
500	13.4	34.9	69.7	104.6	141.0	290.6	523.1
538	7.9	20.7	41.4	62.1	103.4	172.4	310.3

**Table 2-3.18 Ratings for Group 3.18 Materials (Cont'd)**

<b>B — Special Class</b>							
<b>Temperature, °C</b>	<b>Working Pressures by Class, bar</b>						
	<b>150</b>	<b>300</b>	<b>600</b>	<b>900</b>	<b>1500</b>	<b>2500</b>	<b>4500</b>
550	6.7	17.4	34.9	52.3	87.2	145.3	261.5
575	4.5	11.8	23.6	35.4	59.0	98.3	176.9
600	3.2	8.3	16.6	24.9	41.5	69.1	124.5
625	2.5	6.4	12.8	19.3	32.1	53.5	96.3
650	2.3	5.9	11.8	17.7	29.5	49.2	88.6

## NOTES:

- (1) Only use annealed material.  
(2) Flanged-end valve ratings terminate at 538°C.

**Table 2-3.19 Ratings for Group 3.19 Materials**

B435 Gr. N06230 (1)	B564 Gr. N06230 (1)		B572 Gr. N06230 (1)		B622 Gr. N06230 (1)		
<b>A — Standard Class</b>							
Temperature, °C	Working Pressures by Class, bar						
	150	300	600	900	1500	2500	4500
-29 to 38	20.0	51.7	103.4	155.1	258.6	430.9	775.7
50	19.5	51.7	103.4	155.1	258.6	430.9	775.7
100	17.7	51.5	103.0	154.6	257.6	429.4	773.0
150	15.8	50.3	100.3	150.6	250.8	418.2	752.8
200	13.8	48.6	97.2	145.8	243.4	405.4	729.8
250	12.1	46.3	92.7	139.0	231.8	386.2	694.8
300	10.2	42.9	85.7	128.6	214.4	357.1	642.6
325	9.3	41.4	82.6	124.0	206.6	344.3	619.6
350	8.4	40.3	80.4	120.7	201.1	335.3	603.3
375	7.4	38.9	77.6	116.5	194.1	323.2	581.8
400	6.5	36.5	73.3	109.8	183.1	304.9	548.5
425	5.5	35.2	70.0	105.1	175.1	291.6	524.7
450	4.6	33.7	67.7	101.4	169.0	281.8	507.0
475	3.7	31.7	63.4	95.1	158.2	263.9	474.8
500	2.8	28.2	56.5	84.7	140.9	235.0	423.0
538	1.4	25.2	50.0	75.2	125.5	208.9	375.8
550	1.4 (2)	25.0	49.8	74.8	124.9	208.0	374.2
575	1.4 (2)	24.0	47.9	71.8	119.7	199.5	359.1
600	1.4 (2)	21.6	42.9	64.2	107.0	178.5	321.4
625	1.4 (2)	18.3	36.6	54.9	91.2	152.0	273.8
650	1.4 (2)	14.1	28.1	42.5	70.7	117.7	211.7
675	1.4 (2)	12.4	25.2	37.6	62.7	104.5	187.9
700	1.4 (2)	10.1	20.0	29.8	49.7	83.0	149.4
725	1.4 (2)	7.9	15.4	23.2	38.6	64.4	115.8
750	1.4 (2)	5.9	11.7	17.6	29.6	49.1	88.2
775	1.4 (2)	4.6	9.0	13.7	22.8	38.0	68.4
800	1.2 (2)	3.5	7.0	10.5	17.4	29.2	52.6
816	1.0 (2)	2.8	5.9	8.6	14.1	23.8	42.7
<b>B — Special Class</b>							
Temperature, °C	Working Pressures by Class, bar						
	150	300	600	900	1500	2500	4500
-29 to 38	20.0	51.7	103.4	155.1	258.6	430.9	775.7
50	20.0	51.7	103.4	155.1	258.6	430.9	775.7
100	20.0	51.7	103.4	155.1	258.6	430.9	775.7
150	20.0	51.7	103.4	155.1	258.6	430.9	775.7
200	20.0	51.7	103.4	155.1	258.6	430.9	775.7
250	20.0	51.7	103.4	155.1	258.6	430.9	775.7
300	20.0	51.7	103.4	155.1	258.6	430.9	775.7
325	20.0	51.7	103.4	155.1	258.6	430.9	775.7

**Table 2-3.19 Ratings for Group 3.19 Materials (Cont'd)**

<b>B — Special Class</b>							
<b>Temperature, °C</b>	<b>Working Pressures by Class, bar</b>						
	<b>150</b>	<b>300</b>	<b>600</b>	<b>900</b>	<b>1500</b>	<b>2500</b>	<b>4500</b>
350	19.8	51.5	102.8	154.3	257.1	428.6	771.4
375	19.3	50.6	101.0	151.5	252.5	420.9	757.4
400	19.3	50.3	100.6	150.6	251.2	418.3	753.2
425	19.0	49.6	99.3	148.9	248.2	413.7	744.6
450	18.1	47.3	94.4	141.4	235.8	393.1	707.6
475	16.4	42.8	85.5	128.2	213.7	356.3	641.3
500	13.7	35.6	71.5	107.1	178.6	297.5	535.4
538	11.0	29.0	57.9	86.9	145.1	241.7	435.1
550	11.0	29.0	57.9	86.9	145.1	241.7	435.1
575	10.9	28.6	57.1	85.7	143.0	238.3	428.8
600	10.3	26.9	53.5	80.4	134.0	223.4	401.9
625	8.7	23.0	45.7	68.6	114.3	190.6	342.8
650	6.9	17.9	35.5	53.1	88.6	147.9	266.1
675	6.2	16.0	31.6	47.3	78.9	131.7	237.0
700	4.8	12.4	25.0	37.3	62.3	103.7	186.5
725	3.7	9.7	19.5	28.9	48.3	80.2	144.5
750	2.8	7.4	14.8	22.1	36.7	61.2	110.3
775	2.2	5.8	11.4	17.2	28.5	47.6	85.6
800	1.8	4.4	8.8	13.2	22.0	36.6	65.6
816	1.4	3.4	7.2	10.7	17.9	29.6	53.1

## NOTES:

(1) Use annealed material only.

(2) For welding-end valves only. Flanged-end valve ratings terminate at 538°C.



(17)

**Table 3A Valve Body Minimum Wall Thickness,  $t_m$ , mm**

Inside Diameter, $d$ , mm [Note (1)]	Minimum Wall Thickness, $t_m$ , mm						
	Class 150	Class 300	Class 600	Class 900	Class 1500	Class 2500	Class 4500
3	2.5	2.5	2.8	2.8	3.1	3.6	4.9
6	2.7	2.8	3.1	3.2	3.6	4.6	7.2
9	2.9	3.0	3.3	3.6	4.2	5.6	9.6
12	3.1	3.3	3.6	4.1	4.8	6.6	12.0
15	3.3	3.5	3.8	4.5	5.3	7.7	14.3
18	3.5	3.7	4.1	5.0	5.9	8.7	16.7
21	3.7	4.0	4.3	5.4	6.4	9.7	19.0
24	3.9	4.2	4.6	5.9	7.0	10.7	21.4
27	4.1	4.4	4.9	6.4	7.5	11.7	23.7
31	4.3	4.7	5.1	6.7	8.3	13.1	26.9
35	4.6	5.0	5.3	6.9	9.0	14.5	30.0
40	4.9	5.3	5.6	7.2	9.9	16.2	33.9
45	5.2	5.7	5.9	7.5	10.8	17.9	37.9
50	5.5	6.0	6.2	7.8	11.8	19.6	41.8
55	5.6	6.2	6.5	8.3	12.7	21.3	45.7
60	5.7	6.4	6.8	8.8	13.6	23.0	49.6
65	5.8	6.5	7.2	9.3	14.5	24.7	53.6
70	5.9	6.7	7.5	9.9	15.5	26.4	57.5
75	6.0	6.9	7.9	10.4	16.4	28.1	61.4
80	6.1	7.0	8.2	10.9	17.3	29.8	65.3
85	6.2	7.2	8.5	11.4	18.2	31.5	69.3
90	6.3	7.4	8.9	11.9	19.1	33.2	73.2
95	6.4	7.5	9.2	12.5	20.1	34.9	77.1
100	6.5	7.7	9.5	13.0	21.0	36.6	81.0
110	6.5	8.0	10.2	14.0	22.8	40.0	88.9
120	6.7	8.4	10.9	15.1	24.7	43.4	96.7
130	6.8	8.7	11.6	16.1	26.5	46.9	104.6
140	7.0	9.0	12.2	17.2	28.4	50.3	112.4
150	7.1	9.4	12.9	18.2	30.2	53.7	120.3
160	7.3	9.7	13.6	19.3	32.0	57.1	128.1
170	7.5	10.0	14.3	20.3	33.9	60.5	136.0
180	7.6	10.3	14.9	21.3	35.7	63.9	143.8
190	7.8	10.7	15.6	22.4	37.6	67.3	151.7
200	8.0	11.0	16.3	23.4	39.4	70.7	159.5
210	8.1	11.3	17.0	24.5	41.3	74.1	167.4
220	8.3	11.7	17.6	25.5	43.1	77.5	175.2
230	8.4	12.0	18.3	26.6	45.0	80.9	183.1
240	8.6	12.3	19.0	27.6	46.8	84.4	190.9
250	8.8	12.7	19.7	28.7	48.6	87.8	198.8
260	8.9	13.0	20.3	29.7	50.5	91.2	206.6

(17)

**Table 3A Valve Body Minimum Wall Thickness,  $t_m$ , mm (Cont'd)**

Inside Diameter, $d$ , mm [Note (1)]	Minimum Wall Thickness, $t_m$ , mm						
	Class 150	Class 300	Class 600	Class 900	Class 1500	Class 2500	Class 4500
270	9.1	13.3	21.0	30.8	52.3	94.6	214.5
280	9.3	13.6	21.7	31.8	54.2	98.0	222.3
290	9.4	14.0	22.4	32.8	56.0	101.4	230.2
300	9.6	14.3	23.0	33.9	57.9	104.8	238.0
310	9.8	14.6	23.7	34.9	59.7	108.2	245.9
320	9.9	15.0	24.4	36.0	61.6	111.6	253.7
330	10.1	15.3	25.1	37.0	63.4	115.0	261.6
340	10.2	15.6	25.7	38.1	65.2	118.4	269.4
350	10.4	16.0	26.4	39.1	67.1	121.9	277.2
360	10.6	16.3	27.1	40.2	68.9	125.3	285.1
370	10.7	16.6	27.8	41.2	70.8	128.7	292.9
380	10.9	16.9	28.4	42.2	72.6	132.1	300.8
390	11.1	17.3	29.1	43.3	74.5	135.5	308.6
400	11.2	17.6	29.8	44.3	76.3	138.9	316.5
410	11.4	17.9	30.5	45.4	78.2	142.3	324.3
420	11.5	18.3	31.1	46.4	80.0	145.7	332.2
430	11.7	18.6	31.8	47.5	81.8	149.1	340.0
440	11.9	18.9	32.5	48.5	83.7	152.5	347.9
450	12.0	19.3	33.2	49.6	85.5	155.9	355.7
460	12.2	19.6	33.8	50.6	87.4	159.4	363.6
470	12.4	19.9	34.5	51.7	89.2	162.8	371.4
480	12.5	20.2	35.2	52.1	91.1	166.2	379.3
490	12.7	20.6	35.9	53.7	92.9	169.6	387.1
500	12.9	20.9	36.5	54.8	94.8	173.0	395.0
510	13.0	21.2	37.2	55.8	96.6	176.4	402.8
520	13.2	21.6	37.9	56.9	98.4	179.8	410.7
530	13.3	21.9	38.6	57.9	100.3	183.2	418.5
540	13.5	22.2	39.2	59.0	102.1	186.6	426.4
550	13.7	22.6	39.9	60.0	104.0	190.0	434.2
560	13.8	22.9	40.6	61.1	105.8	193.4	442.1
570	14.0	23.2	41.3	62.1	107.7	196.9	449.9
580	14.2	23.5	41.9	63.1	109.5	200.3	457.8
590	14.3	23.9	42.6	64.2	111.4	203.7	465.6
600	14.5	24.2	43.3	65.2	113.2	207.1	473.5
610	14.6	24.5	44.0	66.3	115.0	210.5	481.3
620	14.8	24.9	44.6	67.3	116.9	213.9	489.2
630	15.0	25.2	45.3	68.4	118.7	217.3	497.0
640	15.1	25.5	46.0	69.4	120.6	220.7	504.9
650	15.3	25.9	46.7	70.5	122.4	224.1	512.7
660	15.5	26.2	47.3	71.5	124.3	227.5	520.6

(17)

**Table 3A Valve Body Minimum Wall Thickness,  $t_m$ , mm (Cont'd)**

Inside Diameter, $d$ , mm [Note (1)]	Minimum Wall Thickness, $t_m$ , mm						
	Class 150	Class 300	Class 600	Class 900	Class 1500	Class 2500	Class 4500
670	15.6	26.5	48.0	72.5	126.1	230.9	528.4
680	15.8	26.8	48.7	73.6	128.0	234.4	536.3
690	15.9	27.2	49.4	74.6	129.8	237.8	544.1
700	16.1	27.5	50.0	75.7	131.6	241.2	552.0
710	16.3	27.8	50.7	76.7	133.5	244.6	559.8
720	16.4	28.2	51.4	77.8	135.3	248.0	567.7
730	16.6	28.5	52.1	78.8	137.2	251.4	575.5
740	16.8	28.8	52.7	79.9	139.0	254.8	583.4
750	16.9	29.2	53.4	80.9	140.9	258.2	591.2
760	17.1	29.5	54.1	82.0	142.7	261.6	599.0
770	17.3	29.8	54.8	83.0	144.6	265.0	606.9
780	17.4	30.1	55.4	84.0	146.4	268.4	614.7
790	17.6	30.5	56.1	85.1	148.2	271.9	622.6
800	17.7	30.8	56.8	86.1	150.1	275.3	630.4
820	18.1	31.5	58.1	88.2	153.8	282.1	646.1
840	18.4	32.1	59.5	90.3	157.5	288.9	661.8
860	18.7	32.8	60.8	92.4	161.1	295.7	677.5
880	19.0	33.4	62.2	94.5	164.8	302.5	693.2
900	19.4	34.1	63.5	96.6	168.5	309.4	708.9
920	19.7	34.8	64.9	98.7	172.2	316.2	724.6
940	20.0	35.4	66.2	100.8	175.9	323.0	740.3
960	20.3	36.1	67.6	102.9	179.6	329.6	756.0
980	20.7	36.7	68.9	104.9	183.3	336.6	771.7
1 000	21.0	37.4	70.3	107.0	187.0	343.5	787.4
1 020	21.3	38.1	71.6	109.1	190.7	350.3	803.1
1 040	21.7	38.7	73.0	111.2	194.3	357.1	818.8
1 060	22.0	39.4	74.3	113.3	198.0	363.9	834.5
1 080	22.3	40.0	75.7	115.4	201.7	370.7	850.2
1 100	22.6	40.7	77.0	117.5	205.4	377.5	865.9
1 120	23.0	41.4	78.4	119.6	209.1	384.4	881.6
1 140	23.3	42.0	79.7	121.7	212.8	391.2	897.3
1 160	23.6	42.7	81.1	123.7	216.5	398.0	913.0
1 180	23.9	43.3	82.4	125.8	220.2	404.8	928.7
1 200	24.3	44.0	83.8	127.9	223.9	411.6	944.4
1 220	24.6	44.7	85.1	130.0	227.5	418.5	960.1
1 240	24.9	45.3	86.5	132.1	231.2	425.3	975.8
1 260	25.2	46.0	87.8	134.2	234.9	432.1	991.5
1 280	25.6	46.6	89.2	136.3	238.6	438.9	1007.2
1 300	25.9	47.3	90.5	138.4	242.3	445.7	1022.9
1 320	26.2	48.0	91.9	...	...	...	...

(17)

**Table 3A Valve Body Minimum Wall Thickness,  $t_m$ , mm (Cont'd)**

Inside Diameter, $d$ , mm <a href="#">[Note (1)]</a>	Minimum Wall Thickness, $t_m$ , mm						
	Class 150	Class 300	Class 600	Class 900	Class 1500	Class 2500	Class 4500
1 340	26.5	48.6	93.2	...	...	...	...
1 360	26.9	49.3	94.6	...	...	...	...
1 380	27.2	49.9	95.9	...	...	...	...
1 400	27.5	50.6	97.3	...	...	...	...
1 420	27.8	51.3	98.6	...	...	...	...
1 440	28.2	51.9	100.0	...	...	...	...
1 460	28.5	52.6	101.3	...	...	...	...
1 480	28.8	53.2	102.7	...	...	...	...
1 500	29.2	53.9	104.0	...	...	...	...

NOTE:

(1) See [para. 6.1.2](#).

(17)

**Table 3B Valve Body Minimum Wall Thickness,  $t_m$ , in.**

Inside Diameter, $d$ , in. [Note (1)]	Minimum Wall Thickness, $t_m$ , in.						
	Class 150	Class 300	Class 600	Class 900	Class 1500	Class 2500	Class 4500
0.12	0.10	0.10	0.11	0.11	0.12	0.14	0.19
0.25	0.11	0.11	0.12	0.13	0.15	0.19	0.30
0.37	0.12	0.12	0.13	0.15	0.17	0.23	0.39
0.44	0.12	0.13	0.14	0.16	0.18	0.25	0.45
0.50	0.12	0.13	0.14	0.17	0.19	0.27	0.49
0.56	0.13	0.13	0.15	0.17	0.20	0.29	0.54
0.62	0.13	0.14	0.15	0.18	0.21	0.31	0.59
0.69	0.14	0.15	0.16	0.19	0.23	0.34	0.64
0.75	0.14	0.15	0.16	0.20	0.24	0.36	0.69
0.87	0.15	0.16	0.17	0.22	0.26	0.40	0.78
1.00	0.16	0.17	0.19	0.25	0.28	0.44	0.88
1.12	0.16	0.18	0.19	0.26	0.31	0.48	0.98
1.25	0.17	0.19	0.20	0.26	0.33	0.53	1.08
1.37	0.18	0.20	0.21	0.27	0.35	0.57	1.18
1.50	0.19	0.21	0.22	0.28	0.38	0.61	1.28
1.87	0.21	0.23	0.24	0.30	0.44	0.74	1.57
2.00	0.22	0.24	0.25	0.31	0.47	0.78	1.67
2.25	0.23	0.25	0.26	0.34	0.51	0.87	1.87
2.50	0.23	0.26	0.28	0.36	0.56	0.95	2.06
2.75	0.24	0.27	0.30	0.39	0.61	1.04	2.26
2.87	0.24	0.27	0.30	0.40	0.63	1.08	2.35
3.00	0.24	0.28	0.31	0.41	0.65	1.12	2.45
3.50	0.25	0.30	0.35	0.47	0.75	1.29	2.85
3.62	0.25	0.30	0.35	0.48	0.77	1.33	2.94
3.87	0.26	0.31	0.37	0.50	0.81	1.42	3.14
4.00	0.26	0.31	0.38	0.52	0.84	1.46	3.24
4.37	0.26	0.32	0.40	0.56	0.91	1.59	3.53
4.75	0.26	0.34	0.43	0.60	0.96	1.72	3.83
5.00	0.27	0.35	0.45	0.62	1.02	1.80	4.02
5.37	0.27	0.36	0.47	0.66	1.09	1.93	4.31
5.75	0.28	0.37	0.50	0.70	1.16	2.06	4.61
6.00	0.28	0.38	0.52	0.73	1.21	2.15	4.81
7.00	0.30	0.41	0.58	0.83	1.39	2.49	5.59
7.25	0.30	0.42	0.60	0.86	1.44	2.57	5.79
7.50	0.31	0.43	0.62	0.88	1.48	2.66	5.99
7.87	0.31	0.44	0.64	0.92	1.55	2.78	6.28
8.00	0.32	0.44	0.65	0.94	1.58	2.83	6.38
8.62	0.33	0.46	0.69	1.00	1.69	3.04	6.87
8.75	0.33	0.47	0.70	1.01	1.71	3.08	6.97
9.00	0.33	0.48	0.72	1.04	1.76	3.17	7.16

(17)

**Table 3B Valve Body Minimum Wall Thickness,  $t_m$ , in. (Cont'd)**

Inside Diameter, $d$ , in. [Note (1)]	Minimum Wall Thickness, $t_m$ , in.						
	Class 150	Class 300	Class 600	Class 900	Class 1500	Class 2500	Class 4500
9.37	0.34	0.49	0.74	1.08	1.83	3.29	7.45
9.50	0.34	0.49	0.75	1.09	1.85	3.34	7.56
9.75	0.34	0.50	0.77	1.12	1.90	3.42	7.75
10.00	0.35	0.51	0.79	1.14	1.94	3.51	7.95
10.37	0.35	0.52	0.81	1.18	2.01	3.64	8.24
10.87	0.36	0.54	0.84	1.24	2.10	3.81	8.63
11.00	0.36	0.54	0.85	1.25	2.13	3.85	8.73
11.12	0.37	0.55	0.86	1.26	2.15	3.89	8.83
11.37	0.37	0.56	0.88	1.29	2.20	3.98	9.02
11.75	0.38	0.57	0.90	1.33	2.27	4.11	9.32
12.00	0.38	0.58	0.92	1.35	2.31	4.19	9.52
12.25	0.38	0.58	0.94	1.38	2.36	4.28	9.71
12.87	0.39	0.60	0.98	1.44	2.47	4.49	10.20
13.00	0.40	0.61	0.99	1.46	2.50	4.53	10.30
13.12	0.40	0.61	1.00	1.47	2.52	4.57	10.40
13.25	0.40	0.62	1.00	1.48	2.54	4.62	10.50
13.50	0.41	0.63	1.02	1.51	2.59	4.70	10.70
14.00	0.41	0.64	1.06	1.56	2.68	4.87	11.09
14.62	0.42	0.66	1.10	1.63	2.80	5.08	11.57
14.75	0.43	0.67	1.11	1.64	2.82	5.13	11.68
14.87	0.43	0.67	1.11	1.65	2.84	5.17	11.77
15.00	0.43	0.68	1.12	1.67	2.87	5.21	11.87
15.25	0.43	0.68	1.14	1.69	2.91	5.30	12.07
15.75	0.44	0.70	1.17	1.75	3.00	5.47	12.46
16.00	0.45	0.71	1.19	1.77	3.05	5.55	12.66
16.37	0.45	0.72	1.21	1.81	3.12	5.68	12.95
16.50	0.45	0.72	1.22	1.82	3.14	5.73	13.05
17.00	0.46	0.74	1.26	1.88	3.24	5.90	13.44
17.25	0.47	0.75	1.27	1.90	3.28	5.98	13.64
17.50	0.47	0.76	1.29	1.93	3.33	6.07	13.84
17.62	0.47	0.76	1.30	1.94	3.35	6.11	13.93
18.00	0.48	0.77	1.33	1.98	3.42	6.24	14.23
18.25	0.48	0.78	1.34	2.01	3.47	6.32	14.42
18.87	0.49	0.80	1.38	2.07	3.58	6.53	14.91
19.00	0.49	0.81	1.39	2.09	3.60	6.58	15.01
19.25	0.50	0.82	1.41	2.11	3.65	6.66	15.21
19.62	0.50	0.83	1.43	2.15	3.72	6.79	15.50
20.00	0.51	0.84	1.46	2.19	3.79	6.92	15.80
20.12	0.51	0.84	1.47	2.20	3.81	6.96	15.89
20.37	0.52	0.85	1.48	2.23	3.86	7.04	16.09

(17)

**Table 3B Valve Body Minimum Wall Thickness,  $t_m$ , in. (Cont'd)**

Inside Diameter, $d$ , in. [Note (1)]	Minimum Wall Thickness, $t_m$ , in.						
	Class 150	Class 300	Class 600	Class 900	Class 1500	Class 2500	Class 4500
20.75	0.52	0.86	1.51	2.27	3.93	7.17	16.39
21.00	0.53	0.87	1.53	2.29	3.97	7.26	16.58
21.25	0.53	0.88	1.54	2.32	4.02	7.34	16.78
22.00	0.54	0.91	1.60	2.40	4.16	7.60	17.37
22.62	0.55	0.93	1.64	2.46	4.27	7.81	17.85
22.75	0.56	0.93	1.65	2.48	4.30	7.86	17.96
23.00	0.56	0.94	1.66	2.50	4.34	7.94	18.15
23.25	0.56	0.95	1.68	2.53	4.39	8.03	18.35
23.75	0.57	0.96	1.71	2.58	4.48	8.20	18.74
24.00	0.58	0.97	1.73	2.61	4.53	8.28	18.94
24.25	0.57	0.98	1.75	2.63	4.57	8.37	19.13
24.62	0.58	0.99	1.77	2.67	4.64	8.49	19.42
25.00	0.58	1.01	1.80	2.71	4.71	8.62	19.72
25.25	0.59	1.01	1.81	2.74	4.76	8.71	19.92
25.50	0.59	1.02	1.83	2.76	4.80	8.79	20.11
26.00	0.60	1.04	1.87	2.82	4.90	8.96	20.51
26.25	0.60	1.05	1.88	2.84	4.94	9.05	20.70
26.37	0.60	1.05	1.89	2.86	4.96	9.09	20.80
27.00	0.62	1.07	1.93	2.92	5.08	9.30	21.29
27.25	0.62	1.08	1.95	2.95	5.13	9.39	21.49
27.37	0.62	1.08	1.96	2.96	5.15	9.43	21.58
28.00	0.63	1.10	2.00	3.03	5.26	9.65	22.08
28.25	0.64	1.11	2.02	3.05	5.31	9.73	22.27
29.00	0.65	1.14	2.07	3.13	5.45	9.99	22.86
29.25	0.65	1.15	2.08	3.16	5.49	10.07	23.06
30.00	0.66	1.17	2.14	3.23	5.63	10.33	23.65
31.00	0.68	1.20	2.20	3.34	5.82	10.67	24.43
32.00	0.70	1.24	2.27	3.44	6.00	11.01	25.22
33.00	0.71	1.27	2.34	3.55	6.19	11.35	26.00
34.00	0.73	1.30	2.41	3.65	6.37	11.69	26.79
35.00	0.75	1.34	2.47	3.76	6.56	12.03	27.57
36.00	0.76	1.37	2.54	3.86	6.74	12.37	28.36
37.00	0.78	1.40	2.61	3.97	6.92	12.71	29.14
38.00	0.79	1.43	2.68	4.07	7.11	13.05	29.93
39.00	0.81	1.47	2.74	4.18	7.29	13.40	30.71
40.00	0.83	1.50	2.81	4.28	7.48	13.74	31.50
41.00	0.84	1.53	2.88	4.38	7.66	14.08	32.28
42.00	0.86	1.57	2.95	4.49	7.85	14.42	33.06
43.00	0.88	1.60	3.01	4.59	8.03	14.76	33.85
44.00	0.89	1.63	3.08	4.70	8.21	15.10	34.63

(17)

**Table 3B Valve Body Minimum Wall Thickness,  $t_m$ , in. (Cont'd)**

Inside Diameter, $d$ , in. <a href="#">[Note (1)]</a>	Minimum Wall Thickness, $t_m$ , in.						
	Class 150	Class 300	Class 600	Class 900	Class 1500	Class 2500	Class 4500
45.00	0.91	1.67	3.15	4.80	8.40	15.44	35.42
46.00	0.92	1.70	3.22	4.91	8.58	15.78	36.20
47.00	0.94	1.73	3.28	5.01	8.77	16.12	36.99
48.00	0.96	1.76	3.35	5.12	8.95	16.46	37.77
49.00	0.97	1.80	3.42	5.22	9.14	16.80	38.56
50.00	0.99	1.83	3.49	5.32	9.32	17.15	39.34
51.00	1.02	1.86	3.55	...	...	...	...
52.00	1.03	1.90	3.62	...	...	...	...
53.00	1.05	1.93	3.69	...	...	...	...
54.00	1.07	1.96	3.76	...	...	...	...
55.00	1.08	2.00	3.82	...	...	...	...
56.00	1.10	2.03	3.89	...	...	...	...
57.00	1.11	2.06	3.96	...	...	...	...
58.00	1.13	2.09	4.03	...	...	...	...
59.00	1.15	2.13	4.09	...	...	...	...
60.00	1.16	2.16	4.16	...	...	...	...

NOTE: (1) See [para. 6.1.2.](#)



**Table 4 Minimum Wall Thickness for Socket Welding and Threaded Ends**

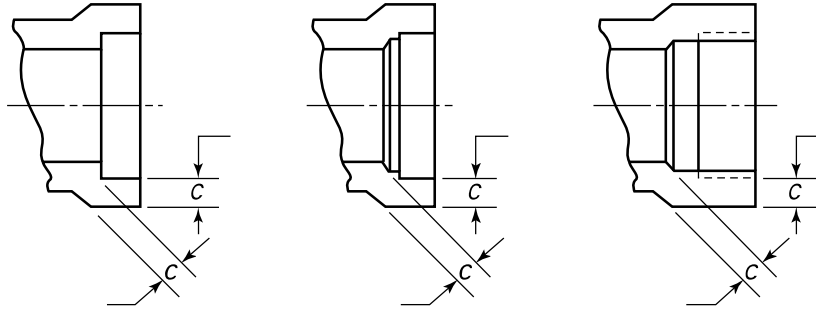

Classes 150 and 300	Class 600		Class 800 [Note (1)]		Class 900		Class 1500		Class 2500		Class 4500			
	mm	in.	mm	in.	mm	in.	mm	in.	mm	in.	mm	in.		
<b>Minimum Wall Thickness, C</b>														
<b>NPS</b>	<b>mm</b>	<b>in.</b>	<b>mm</b>	<b>in.</b>	<b>mm</b>	<b>in.</b>	<b>mm</b>	<b>in.</b>	<b>mm</b>	<b>in.</b>	<b>mm</b>	<b>in.</b>	<b>mm</b>	<b>in.</b>
1/8	3.0	0.12	3.0	0.12	3.0	0.12	3.6	0.14	3.6	0.14	5.3	0.21	5.6	0.22
1/4	3.0	0.12	3.3	0.13	3.3	0.13	4.1	0.16	4.1	0.16	6.6	0.26	7.4	0.29
3/8	3.0	0.12	3.6	0.14	3.6	0.14	4.3	0.17	4.3	0.17	7.1	0.28	9.4	0.37
1/2	3.3	0.13	4.1	0.16	4.1	0.16	5.3	0.21	5.3	0.21	8.1	0.32	11.2	0.44
3/4	3.6	0.14	4.3	0.17	4.3	0.17	6.1	0.24	6.1	0.24	8.6	0.34	13.0	0.51
1	3.8	0.15	5.1	0.20	5.1	0.20	6.9	0.27	6.9	0.27	9.9	0.39	15.7	0.62
1 1/4	3.8	0.15	5.3	0.21	5.3	0.21	7.1	0.28	8.1	0.32	11.7	0.46	19.1	0.75
1 1/2	4.1	0.16	5.6	0.22	5.8	0.23	7.9	0.31	8.9	0.35	13.0	0.51	21.3	0.84
2	4.6	0.18	6.1	0.24	6.9	0.27	9.7	0.38	10.7	0.42	15.7	0.62	25.9	1.02
2 1/2	5.6	0.22	7.6	0.30	7.9	0.31	10.4	0.41	12.4	0.49	18.5	0.73	31.0	1.22

NOTE: (1) Class 800 is not a tabulated ASME B16.34 designation. It is an intermediate class that is widely used for socket welding and threaded end valves.

# MANDATORY APPENDIX I

## RADIOGRAPHY EXAMINATION: PROCEDURE AND ACCEPTANCE STANDARDS

### I-1 RADIOGRAPHY PROCEDURE

(a) ASTM E94, Standard Guide for Radiographic Examination, shall be used as a guide.

(b) The film shall be as close as practical to the part being radiographed.

(c) Any commercially available intensifying screen, except those of the fluorescent type, may be used.

(d) All film shall bear identification markers to properly orient the film for interpretation and to denote the actual part under examination. Film shall be marked to identify the organization producing the radiograph and the date exposed.

(e) Penetrators shall be used on each radiograph. Penetrators shall conform to the requirements of ASTM E94.

(f) Any commercially available film may be used, provided it is equal to or finer grained than Type 2, ASTM E94.

(g) The manufacturer, at his option, may use a double film technique and a combination of a single and double viewing so as to cover a greater latitude in part thickness with a single exposure.

(h) Radiographs shall be within the following photographic (H&D) density range:

(1) single film viewing — 1.5 min., 4.0 max.

(2) superimposed viewing of double film, each single film — 1.00 min., 2.5 max., with a double film — 4.0 max.

(i) Surfaces shall be such that radiographic contrast due to surface condition cannot mask or be confused with that of any defect.

(j) Single-wall thickness shall be radiographed wherever practical.

(k) The radiographic sensitivity shall be  $2 - 4T$  for thickness up to and including 19 mm (0.75 in.) and  $2 - 2T$  for thickness greater than 19 mm (0.75 in.).

### I-2 ACCEPTANCE STANDARDS

(a) For wall thickness  $t \leq 50$  mm ( $t \leq 2$  in.) the comparative plates of ASTM E446 define acceptable indications as shown in [Table I-1](#).

(b) For wall thickness  $50$  mm  $< t \leq 115$  mm ( $2$  in.  $< t \leq 4.5$  in.) the comparative plates of ASTM E186 define acceptable indications as shown in [Table I-2](#).

(c) For wall thickness  $115$  mm  $< t \leq 305$  mm ( $4.5$  in.  $< t \leq 12$  in.) the comparative plates of ASTM E280 define acceptable indications as shown in [Table I-3](#).

**Table I-1 Acceptance Criteria for Thickness per  
Para. I-2(a)**

Discontinuity Type	Category	Acceptable Comparative Plate ASTM E446
Gas	A	A2
Sand	B	B3
Shrink, Type 1	C	CA2
Shrink, Type 2	C	CB3
Shrink, Type 3	C	CC3
Shrink, Type 4	C	CD3
Hot tears and cracks	D & E	None
Inserts (chills, chaplets)	F	None

**Table I-2 Acceptance Criteria for Thickness per  
Para. I-2(b)**

Discontinuity Type	Category	Acceptable Comparative Plate ASTM E186
Gas porosity	A	A3
Sand and slag inclusions	B	B3
Shrink, Type 1	C	CA3
Shrink, Type 2	C	CB3
Shrink, Type 3	C	CC3
Crack	D	None
Hot tear	E	None
Insert	F	None

**Table I-3 Acceptance Criteria for Thickness per  
Para. I-2(c)**

Discontinuity Type	Category	Acceptable Comparative Plate ASTM E186
Gas porosity	A	A3
Sand and slag inclusions	B	B3
Shrink, Type 1	C	CA3
Shrink, Type 2	C	CB3
Shrink, Type 3	C	CC3
Crack	D	None
Hot tear	E	None
Insert	F	None

# MANDATORY APPENDIX II

## MAGNETIC PARTICLE EXAMINATION: PROCEDURE AND ACCEPTANCE STANDARDS

### II-1 PROCEDURE

Magnetic particle examination procedure for castings shall be in accordance with ASTM E709, Standard Guide for Magnetic Particle Testing. For forgings, plates, and bars, the examination procedures shall be in accordance with ASTM A275, Magnetic Particle Examination of Steel Forgings.

### II-2 ACCEPTANCE STANDARDS<sup>1</sup>

#### II-2.1 Castings

Maximum acceptable indications are as follows:

*(a) Linear Indications*

- (1) 8-mm (0.3-in.) long for materials up to 13-mm (0.5-in.) thick
- (2) 13-mm (0.5-in.) long for materials 13-mm to 25-mm (0.5-in. to 1.0-in.) thick
- (3) 18-mm (0.7-in.) long for materials over 25-mm (1.0-in.) thick

For linear indications, the indications must be separated by a distance greater than the length of an acceptable indication. A linear indication is one with length in excess of 3 times the width.

*(b) Rounded Indications*

- (1) 8-mm (0.3-in.) diameter for materials up to 13-mm (0.5-in.) thick
- (2) 13-mm (0.5-in.) diameter for materials over 13-mm (0.5-in.) thick

Four or more rounded indications in a line separated by 1.5 mm (0.06 in.) or less edge-to-edge are unacceptable. Rounded indications are those that are not defined as linear indications.

#### II-2.2 Forgings and Rolled or Wrought Material

Maximum acceptable indications are as follows:

*(a) Linear Indications*

- (1) 5-mm (0.2-in.) long for materials up to 13-mm (0.5-in.) thick
- (2) 10-mm (0.4-in.) long for materials over 13-mm (0.5-in.) to 25-mm (1-in.) thick
- (3) 15-mm (0.6-in.) long for materials over 25-mm (1.0-in.) thick.

For linear indications, the indications must be separated by a distance greater than the length of an acceptable indication. A linear indication is one with length in excess of 3 times the width.

*(b) Rounded Indications*

- (1) 5-mm (0.2-in.) diameter for materials up to 13-mm (0.5-in.) thick
- (2) 8-mm (0.3-in.) diameter for materials over 13-mm (0.5-in.) thick.

Four or more rounded indications in a line separated by 1.5 mm (0.06 in.) or less edge-to-edge are unacceptable. Rounded indications are those that are not defined as linear indications.

<sup>1</sup>An indication may be larger than the imperfection that causes it; however, the size of the indication is the basis for acceptance evaluation.

# MANDATORY APPENDIX III

## LIQUID PENETRANT EXAMINATION: PROCEDURE AND ACCEPTANCE STANDARDS

### III-1 PROCEDURE

Liquid penetrant procedure shall be in accordance with ASTM E165.

### III-2 ACCEPTANCE STANDARDS<sup>1</sup>

#### III-2.1 Castings

Maximum acceptable indications are as follows:

*(a) Linear Indications*

(1) 8-mm (0.3-in.) long for materials up to 13-mm (0.5-in.) thick

(2) 13-mm (0.5-in.) long for materials 13-mm to 25-mm (0.5-in. to 1.0-in.) thick

(3) 18-mm (0.7-in.) long for materials over 25-mm (1.0-in.) thick

For linear indications, the indications must be separated by a distance greater than the length of an acceptable indication. A linear indication is one with length in excess of 3 times the width.

*(b) Rounded Indications*

(1) 8-mm (0.3-in.) diameter for materials up to 13-mm (0.5-in.) thick

(2) 13-mm (0.5-in.) diameter for materials over 13-mm (0.5-in.) thick

Four or more rounded indications in a line separated by 1.5 mm (0.06 in.) or less edge-to-edge are unacceptable. Rounded indications are those that are not defined as linear indications.

#### III-2.2 Forgings and Rolled or Wrought Material

Maximum acceptable indications are as follows:

*(a) Linear Indications*

(1) 5-mm (0.2-in.) long for materials 13-mm (0.5-in.) or less thick

(2) 10-mm (0.4-in.) long for materials over 13-mm (0.5-in.) to 25-mm (1.0-in.) thick

(3) 15-mm (0.6-in.) long for materials over 25-mm (1.0-in.) thick

For linear indications, the indications must be separated by a distance greater than the length of an acceptable indication. A linear indication is one with length in excess of 3 times the width.

*(b) Rounded Indications*

(1) 5-mm (0.2-in.) diameter for materials up to 13-mm (0.5-in.) thick

(2) 8-mm (0.3-in.) diameter for materials over 13-mm (0.5-in.) thick

Four or more rounded indications in a line separated by 1.5 mm (0.06 in.) or less edge-to-edge are unacceptable. Rounded indications are those that are not defined as linear indications.

<sup>1</sup>An indication may be larger than the imperfection that causes it; however, the size of the indication is the basis for acceptance evaluation.

## **MANDATORY APPENDIX IV ULTRASONIC EXAMINATION: PROCEDURE AND ACCEPTANCE STANDARDS**

### **IV-1 PROCEDURE**

Ultrasonic examination procedure shall meet the requirements of ASTM A388 for forgings, bars, plates, and tubular products and ASTM A609 for castings.

### **IV-2 ACCEPTANCE STANDARDS**

#### **IV-2.1 Straight Beam Examination**

Indications that are equal to or exceed that obtained from a 6.4-mm (0.25-in.) diameter, flat-bottomed hole in a calibration test piece of thickness equal to the defect depth are unacceptable.

#### **IV-2.2 Angle Beam Examination**

Indications that are equal to or exceed those obtained from a 60-deg V-notch, 25-mm (1.0-in.) long and having a depth not greater than 5% of the nominal wall thickness in a test piece are unacceptable.

# MANDATORY APPENDIX V

## REQUIREMENTS FOR LIMITED CLASS VALVES

### V-1 GENERAL

This Appendix covers alternative requirements for valves having either threaded or welding ends and is specifically restricted to NPS 2½ and smaller. Valves complying with the requirements of this Appendix may be designated as Limited Class. There is no provision for this designation for flanged end valves.

#### V-1.2 Applicability

The paragraphs of this Appendix are numbered corresponding with those of the body of this Standard. All requirements for Standard Class valves are applicable to Limited Class except as otherwise modified by this Appendix.

#### V-2.1 General

Valves conforming to the requirements of this Appendix and identified as Limited Class shall be suitable for pressure-temperature ratings determined in accordance with [para. V-2.1.3](#). Threaded-end valves rated above Class 2500 and socket-weld-end valves rated above Class 4500 are not within the scope of this Standard.

**V-2.1.3 Limited Class Rating Method.** Pressure-temperature ratings for Limited Class valves are established for Groups 1 and 2 materials of [Table V-1](#) by the equation

$$p_{ld} = \frac{7000}{7000 - (y - 0.4)P_r} p_{sp}$$

where

$P_r$  = pressure class rating index. For all designations Class 300 through 4500,  $P_r$  is equal to the Class designation number (e.g., for Class 300,  $P_r = 300$ ). For Class 150,  $P_r = 115$ . For a rating designation between Class 150 and Class 300, the interpolation shall be made using  $P_r = 115$  for Class 150. The equation is not valid for  $P_r$  greater than 4500.

$p_{ld}$  = Limited Class rated working pressure for the specified material at temperature  $T$

$p_{sp}$  = Special Class rated working pressure for the specified material at temperature  $T$  as determined by the method of [Nonmandatory Appendix B](#). These Special Class working pressures are tabulated in [Table 2-1.1](#) through

[Table 2-3.19](#) having a designation of "Special Class." The tabulated values shall be used for establishing Limited Class ratings.

$y$  = a material coefficient having values as listed in [Table V-1](#)

In no case shall the working pressure increase with increasing temperature. This shall be verified by the manufacturer for all rating points greater than 480°C (900°F) for ferritic steels and 565°C (1,050°F) for austenitic steels.

**V-2.1.6 Fabrication by Welding.** Fabricated valves that are identified as Limited Class shall conform with the requirements of [para. 2.1.6\(c\)\(2\)](#) for Special Class.

**V-4.2.3 Rating.** Valves shall be marked on the valve body with the number for the appropriate pressure rating class designation except that Limited Class and Intermediate Rating Limited Class may instead be marked on the valve body with a specific rated pressure and temperature. For all valves in Limited Class, the identification plate shall show the applicable pressure rating at 38°C (100°F) and other markings required by MSS SP-25. Valves conforming to Limited Class requirements, and acknowledged as such, shall include the designation "B16.34LTD" on the identification plate.

### V-6.1 Body Dimensions

Limited Class is restricted in application to valve body geometries that have internal wetted pressure boundary surfaces that are generally characterized by cylindrical passages, cylindrical or spherical chambers, and intersections thereof.

**V-6.1.1 Wall Thickness.** For inspection purposes, the minimum thickness of the wall surrounding the body run flow passage shall be as shown in [Table 3A](#) or [Table 3B](#) as applicable.

**V-6.1.2 Inside Diameter.** For the purpose of determining flow passageway wall thickness, the inside diameter,  $d$  (see [Figure V-1](#)), is the diameter of the cylindrical flow passage.

**V-6.1.3 Valve Body Necks.** The minimum thickness of the wall for the body neck shall be that shown in [Table 3A](#) or [Table 3B](#) with  $d$  for this determination taken as two-

**Table V-1 Material Coefficient,  $y$**

Material	Applicable Temperature					620°C (1,150°F) and Above
	480°C (900°F) and Below	510°C (950°F)	538°C (1,000°F)	565°C (1,050°F)	595°C (1,100°F)	
Ferritic steels	0.4	0.5	0.7	0.7	0.7	0.7
Austenitic steels	0.4	0.4	0.4	0.4	0.5	0.7
Other ductile materials	0.4	0.4	0.4	0.4	0.4	0.4

**Figure V-1 Limited Class Stress Area Limits**

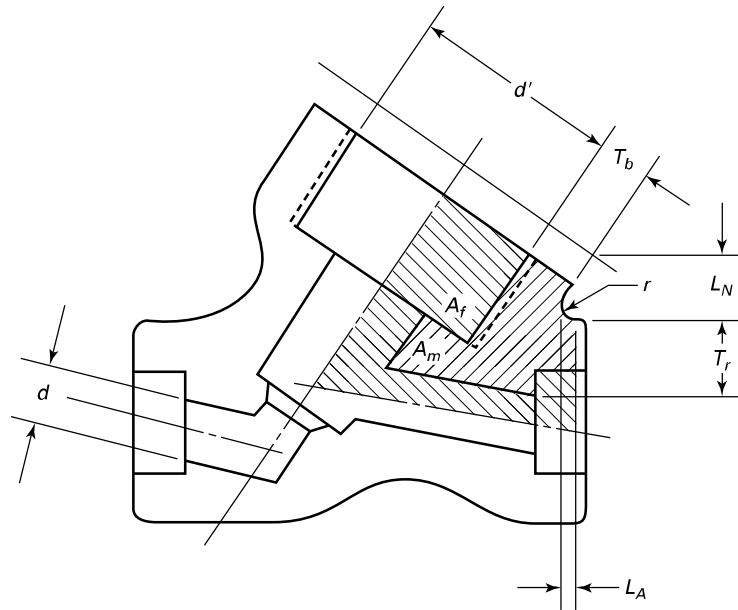

thirds of  $d'$  where  $d'$  is the inside diameter of the body neck. In no case shall the body neck thickness be less than the minimum value determined for the flow passage in para. V-6.1.1. For values of body neck inside diameter not shown in Table 3A or Table 3B as applicable, interpolation is permitted.

**V-6.1.5 Contours for Body Run Transitions.** The requirements of para. 6.1.5 are not applicable to Limited Class.

**V-6.1.8 Additional Metal Thickness.** For Limited Class, it is required that metal thickness reinforcement be provided to satisfy the following:

$$S_o \geq p_o \left( \frac{A_f}{A_m} + 0.5 \right)$$

where

- $A_f$  = fluid area (see Figure V-1)
- $A_m$  = metal area (see Figure V-1)
- $p_o$  = rated working pressure at 38°C (100°F)

$S_o$  = the lesser value of either two-thirds of the yield strength, one quarter of the ultimate tensile strength, or the allowable stress of the body material at 38°C (100°F) as listed in the ASME Boiler and Pressure Vessel Code, Section II, Part D, for either Section I or Section VIII, Division 1

The fluid area and metal area are determined from a drawing of the valve body crotch region in the mutual plane of the bonnet and flow passage center lines (see Figure V-1).<sup>1</sup> The fluid and metal areas are to be based on the most adverse combination of dimensions permitted by tolerances. In Figure V-1, the distances  $L_N$  and  $L_A$  that define fluid and metal area boundaries are determined as

$$L_N = 0.5r + 0.354\sqrt{T_b(d' + T_b)}$$

and  $L_A$  as the larger of

<sup>1</sup> For guidance in regard to other valve configurations, see ASME Boiler and Pressure Vessel Code, Section III, Subsection NB, NB-3545.



$$L_A = 0.5d' - T_b$$

or

$$L_A = T_r$$

where

$d'$  = body neck inside diameter at crotch region

$r$  = external fillet radius at crotch

$T_b$  = neck wall thickness at crotch region

$T_r$  = body run wall thickness at crotch region

If a calculated boundary lies beyond the body run end or neck end, the sections to be used for area determination shall terminate at the body run end or neck end.

## MANDATORY APPENDIX VI

### BASIS EQUATIONS FOR MINIMUM WALL THICKNESS

#### VI-1 MINIMUM WALL THICKNESS EQUATIONS

Minimum wall thickness requirements may be satisfied by compliance with either the values shown in [Table 3A](#) or [Table 3B](#) as applicable or the use of the equations listed in this Appendix (see [Tables VI-1](#) and [VI-2](#)). Refer to [para. 1.2.5](#) concerning valid units.

#### VI-2 DESIGN VALUES

The wall thickness values obtained from [Table 3A](#), [Table 3B](#), or the equations given in this Appendix are not to be interpreted as design values. They are, in basic terms, minimum requirements that must be met in order to be in conformance with this Standard.

(17) **Table VI-1 Basis Equations for Minimum Wall Thickness, mm**

Class $P_c$	Diameter, $d$ , mm	Metric Equation, $t_m$ , mm	Round
150	$3 \leq d < 50$	$t_m (150) = 0.064d + 2.34$	off, one decimal
150	$50 \leq d \leq 100$	$t_m (150) = 0.020d + 4.50$	off, one decimal
150	$100 < d \leq 1\ 500$	$t_m (150) = 0.0163d + 4.70$	off, one decimal
300	$3 \leq d < 25$	$t_m (300) = 0.080d + 2.29$	off, one decimal
300	$25 \leq d \leq 50$	$t_m (300) = 0.07d + 2.54$	off, one decimal
300	$50 < d \leq 1\ 500$	$t_m (300) = 0.033d + 4.40$	off, one decimal
600	$3 \leq d < 25$	$t_m (600) = 0.086d + 2.54$	off, one decimal
600	$25 \leq d \leq 50$	$t_m (600) = 0.058d + 3.30$	off, one decimal
600	$50 < d \leq 1\ 500$	$t_m (600) = 0.0675d + 2.79$	off, one decimal
900	$3 \leq d < 25$	$t_m (900) = 0.15d + 2.29$	off, one decimal
900	$25 \leq d \leq 50$	$t_m (900) = 0.059d + 4.83$	off, one decimal
900	$50 < d \leq 1\ 300$	$t_m (900) = 0.10449d + 2.54$	off, one decimal
1500	$3 \leq d \leq 1\ 300$	$t_m (1500) = 0.18443d + 2.54$	off, one decimal
2500	$3 \leq d \leq 1\ 300$	$t_m (2500) = 0.34091d + 2.54$	off, one decimal
4500	$3 \leq d \leq 1\ 300$	$t_m (4500) = 0.78488d + 2.54$	off, one decimal

GENERAL NOTES:

(a) For  $t_m$ , see [para. 6.1.1](#).

(b) For  $d$ , see [para. 6.1.2](#).

(17)

**Table VI-2 Basis Equations for Minimum Wall Thickness, in.**

Class $P_c$	Diameter, $d$ , in.	Inch Equation, $t_m$ , in.	Round
150	$0.12 \leq d < 2$	$t_m(150) = 0.064d + 0.092$	off, two decimals
150	$2 \leq d \leq 4$	$t_m(150) = 0.020d + 0.18$	off, two decimals
150	$4 < d \leq 60$	$t_m(150) = 0.0163d + 0.185$	off, two decimals
300	$0.12 \leq d < 1$	$t_m(300) = 0.080d + 0.09$	off, two decimals
300	$1 \leq d \leq 2$	$t_m(300) = 0.07d + 0.10$	off, two decimals
300	$2 < d \leq 60$	$t_m(300) = 0.033d + 0.18$	off, two decimals
600	$0.12 \leq d < 1$	$t_m(600) = 0.086d + 0.10$	off, two decimals
600	$1 \leq d \leq 2$	$t_m(600) = 0.058d + 0.13$	off, two decimals
600	$2 < d \leq 60$	$t_m(600) = 0.0675d + 0.11$	off, two decimals
900	$0.12 \leq d < 1$	$t_m(900) = 0.15d + 0.09$	off, two decimals
900	$1 \leq d \leq 2$	$t_m(900) = 0.059d + 0.19$	off, two decimals
900	$2 < d \leq 50$	$t_m(900) = 0.10449d + 0.10$	off, two decimals
1500	$0.12 \leq d \leq 50$	$t_m(1500) = 0.18443d + 0.10$	off, two decimals
2500	$0.12 \leq d \leq 50$	$t_m(2500) = 0.34091d + 0.10$	off, two decimals
4500	$0.12 \leq d \leq 50$	$t_m(4500) = 0.78488d + 0.10$	off, two decimals

## GENERAL NOTES:

(a) For  $t_m$ , see para. 6.1.1.(b) For  $d$ , see para. 6.1.2.

## MANDATORY APPENDIX VII

### PRESSURE–TEMPERATURE RATINGS: U.S. CUSTOMARY UNITS<sup>1</sup>

In [Table 2-1.1](#) through [Table 2-3.19](#), the pressure–temperature ratings are listed using bar as the unit for pressure (1 bar = 100 kPa) and degrees Celsius for the unit for temperature. In this Appendix, the pressure–temperature ratings are shown using psi units for pres-

sure and degrees Fahrenheit as the units for temperature. These [Mandatory Appendix VII](#) ratings are coterminous with those of [Table 2-1.1](#) through [Table 2-3.19](#). All working pressures are gage pressure.

---

<sup>1</sup>For metric units, see [Table 2-1.1](#) through [Table 2-3.19](#).

(17)

**Table VII-2-1.1 Ratings for Group 1.1 Materials**

A105 (1), (2)	A350 Gr. LF3 (6)	A516 Gr. 70 (1), (4)	A672 Gr. C70 (1)
A216 Gr. WCB (1)	A350 Gr. LF6 Cl.1 (5)	A537 Cl. 1 (3)	A696 Gr. C (3)
A350 Gr. LF2 (1)	A515 Gr. 70 (1)	A672 Gr. B70 (1)	

**A — Standard Class**

Temperature, °F	Working Pressures by Class, psig						
	150	300	600	900	1500	2500	4500
-20 to 100	285	740	1,480	2,220	3,705	6,170	11,110
200	260	680	1,360	2,035	3,395	5,655	10,185
300	230	655	1,310	1,965	3,270	5,450	9,815
400	200	635	1,265	1,900	3,170	5,280	9,505
500	170	605	1,205	1,810	3,015	5,025	9,040
600	140	570	1,135	1,705	2,840	4,730	8,515
650	125	550	1,100	1,650	2,745	4,575	8,240
700	110	530	1,060	1,590	2,655	4,425	7,960
750	95	505	1,015	1,520	2,535	4,230	7,610
800	80	410	825	1,235	2,055	3,430	6,170
850	65	320	640	955	1,595	2,655	4,785
900	50	230	460	690	1,150	1,915	3,455
950	35	135	275	410	685	1,145	2,055
1,000	20	85	170	255	430	715	1,285

**B — Special Class**

Temperature, °F	Working Pressure by Class, psig						
	150	300	600	900	1500	2500	4500
-20 to 100	290	750	1,500	2,250	3,750	6,250	11,250
200	290	750	1,500	2,250	3,750	6,250	11,250
300	285	740	1,480	2,220	3,700	6,170	11,105
400	280	735	1,465	2,200	3,665	6,105	10,995
500	280	735	1,465	2,200	3,665	6,105	10,995
600	280	735	1,465	2,200	3,665	6,105	10,995
650	275	715	1,430	2,145	3,575	5,960	10,730
700	265	690	1,380	2,075	3,455	5,760	10,365
750	245	635	1,270	1,905	3,170	5,285	9,515
800	195	515	1,030	1,545	2,570	4,285	7,715
850	155	400	795	1,195	1,995	3,320	5,980
900	110	285	575	860	1,435	2,395	4,305
950	65	170	345	515	855	1,430	2,570
1,000	40	105	215	320	535	895	1,605

## NOTES:

- (1) Upon prolonged exposure to temperatures above 800°F, the carbide phase of steel may be converted to graphite. Permissible, but not recommended for prolonged use above 800°F.
- (2) Only killed steel shall be used above 850°F.
- (3) Not to be used over 700°F.
- (4) Not to be used over 850°F.
- (5) Not to be used over 500°F.
- (6) Not to be used over 650°F.

**Table VII-2-1.2 Ratings for Group 1.2 Materials**

A106 Gr. C (1)	A203 Gr. E (2)	A350 Gr. LF6 Cl. 2 (3)	A352 Gr. LC3 (4)				
A203 Gr. B (2)	A216 Gr. WCC (2)	A352 Gr. LC2 (4)	A352 Gr. LCC (4)				
<b>A — Standard Class</b>							
Temperature, °F	Working Pressures by Class, psig						
	150	300	600	900	1500	2500	4500
-20 to 100	290	750	1,500	2,250	3,750	6,250	11,250
200	260	750	1,500	2,250	3,750	6,250	11,250
300	230	730	1,455	2,185	3,640	6,070	10,925
400	200	705	1,405	2,110	3,520	5,865	10,555
500	170	665	1,330	1,995	3,325	5,540	9,965
600	140	605	1,210	1,815	3,025	5,040	9,070
650	125	590	1,175	1,765	2,940	4,905	8,825
700	110	555	1,110	1,665	2,775	4,630	8,330
750	95	505	1,015	1,520	2,535	4,230	7,610
800	80	410	825	1,235	2,055	3,430	6,170
850	65	320	640	955	1,595	2,655	4,785
900	50	225	445	670	1,115	1,855	3,345
950	35	135	275	410	685	1,145	2,055
1,000	20	85	170	255	430	715	1,285
<b>B — Special Class</b>							
Temperature, °F	Working Pressure by Class, psig						
	150	300	600	900	1500	2500	4500
-20 to 100	290	750	1,500	2,250	3,750	6,250	11,250
200	290	750	1,500	2,250	3,750	6,250	11,250
300	290	750	1,500	2,250	3,750	6,250	11,250
400	290	750	1,500	2,250	3,750	6,250	11,250
500	290	750	1,500	2,250	3,750	6,250	11,250
600	290	750	1,500	2,250	3,750	6,250	11,250
650	290	750	1,500	2,250	3,750	6,250	11,250
700	280	715	1,425	2,140	3,565	5,940	10,690
750	280	635	1,270	1,905	3,170	5,285	9,515
800	255	515	1,030	1,545	2,570	4,285	7,715
850	200	400	795	1,195	1,995	3,320	5,980
900	140	280	555	835	1,395	2,320	4,180
950	85	170	345	515	855	1,430	2,570
1,000	55	105	215	320	535	895	1,605

## NOTES:

- (1) Not to be used over 800°F.
- (2) Upon prolonged exposure to temperatures above 800°F, the carbide phase of steel may be converted to graphite. Permissible, but not recommended for prolonged use above 800°F.
- (3) Not to be used over 500°F.
- (4) Not to be used over 650°F.

**Table VII-2-1.3 Ratings for Group 1.3 Materials**

A203 Gr. A (1)	A352 Gr. LCB (2)	A516 Gr. 65 (1), (3)	A672 Gr. B65 (1)
A203 Gr. D (1)	A352 Gr. LC1 (2)	A675 Gr. 70 (1), (4), (5)	A672 Gr. C65 (1)
A217 Gr. WC1 (6)-(8)	A515 Gr. 65 (1)		

**A — Standard Class**

Temperature, °F	Working Pressures by Class, psig						
	150	300	600	900	1500	2500	4500
-20 to 100	265	695	1,395	2,090	3,480	5,805	10,445
200	255	660	1,320	1,980	3,300	5,505	9,905
300	230	640	1,275	1,915	3,190	5,315	9,565
400	200	615	1,230	1,845	3,075	5,125	9,225
500	170	585	1,175	1,760	2,930	4,885	8,795
600	140	550	1,105	1,655	2,755	4,595	8,270
650	125	535	1,065	1,600	2,665	4,440	7,990
700	110	510	1,025	1,535	2,560	4,270	7,685
750	95	475	955	1,430	2,385	3,970	7,150
800	80	390	780	1,175	1,955	3,255	5,865
850	65	300	595	895	1,490	2,485	4,475
900	50	200	405	605	1,010	1,685	3,035
950	35	135	275	410	685	1,145	2,055
1,000	20	85	170	255	430	715	1,285

**B — Special Class**

Temperature, °F	Working Pressure by Class, psig						
	150	300	600	900	1500	2500	4500
-20 to 100	290	695	1,395	2,090	3,480	5,805	10,445
200	290	695	1,395	2,090	3,480	5,805	10,445
300	290	695	1,395	2,090	3,480	5,805	10,445
400	290	695	1,395	2,090	3,480	5,805	10,445
500	290	695	1,395	2,090	3,480	5,805	10,445
600	290	695	1,395	2,090	3,480	5,805	10,445
650	290	695	1,390	2,080	3,470	5,780	10,405
700	280	660	1,320	1,985	3,305	5,510	9,915
750	280	595	1,190	1,785	2,980	4,965	8,935
800	245	490	975	1,465	2,445	4,070	7,330
850	185	375	745	1,120	1,865	3,105	5,595
900	125	255	505	760	1,265	2,105	3,795
950	85	170	345	515	855	1,430	2,570
1,000	55	105	215	320	535	895	1,605

## NOTES:

- (1) Upon prolonged exposure to temperatures above 800°F, the carbide phase of steel may be converted to graphite. Permissible, but not recommended for prolonged use above 800°F.
- (2) Not to be used over 650°F.
- (3) Not to be used over 850°F.
- (4) Leaded grades shall not be used where welded or in any application above 500°F.
- (5) For service temperatures above 850°F, it is recommended that killed steel containing not less than 0.10% residual silicon be used.
- (6) Upon prolonged exposure to temperatures above 875°F, the carbide phase of steel of carbon-molybdenum steel may be converted to graphite. Permissible, but not recommended for prolonged use above 875°F.
- (7) Use normalized and tempered material only.

**Table VII-2-1.3 Ratings for Group 1.3 Materials (Cont'd)**

---

NOTES (Cont'd):

- (8) The deliberate addition of any element not listed in ASTM A217, Table 1 is prohibited, except that calcium (Ca) and manganese (Mn) may be added for deoxidation.



**Table VII-2-1.4 Ratings for Group 1.4 Materials**

A106 Gr. B (1)	A516 Gr. 60 (1), (2)	A675 Gr. 60 (1)-(3)
A350 Gr. LF1 Cl. 1 (1)	A672 Gr. B60 (1)	A675 Gr. 65 (1), (3), (4)
A515 Gr. 60 (1), (2)	A672 Gr. C60 (1)	A696 Gr. B (5)

**A — Standard Class**

Temperature, °F	Working Pressures by Class, psig						
	150	300	600	900	1500	2500	4500
-20 to 100	235	615	1,235	1,850	3,085	5,145	9,255
200	215	565	1,130	1,695	2,830	4,715	8,485
300	210	545	1,090	1,635	2,725	4,545	8,175
400	200	525	1,055	1,580	2,635	4,390	7,900
500	170	500	1,005	1,505	2,510	4,185	7,530
600	140	475	945	1,420	2,365	3,945	7,095
650	125	455	915	1,370	2,285	3,805	6,850
700	110	440	885	1,325	2,210	3,685	6,635
750	95	430	855	1,285	2,140	3,565	6,420
800	80	370	740	1,110	1,850	3,085	5,555
850	65	300	595	895	1,490	2,485	4,475
900	50	170	345	515	855	1,430	2,570
950	35	135	275	410	685	1,145	2,055
1,000	20	85	170	255	430	715	1,285

**B — Special Class**

Temperature, °F	Working Pressure by Class, psig						
	150	300	600	900	1500	2500	4500
-20 to 100	245	645	1,285	1,930	3,215	5,355	9,645
200	245	645	1,285	1,930	3,215	5,355	9,645
300	245	645	1,285	1,930	3,215	5,355	9,645
400	245	645	1,285	1,930	3,215	5,355	9,645
500	245	645	1,285	1,930	3,215	5,355	9,645
600	235	615	1,230	1,850	3,080	5,135	9,240
650	230	595	1,190	1,785	2,975	4,955	8,920
700	220	575	1,150	1,730	2,880	4,800	8,640
750	215	555	1,115	1,670	2,785	4,645	8,355
800	175	465	925	1,390	2,315	3,855	6,945
850	145	375	745	1,120	1,865	3,105	5,595
900	80	215	430	645	1,070	1,785	3,215
950	65	170	345	515	855	1,430	2,570
1,000	40	105	215	320	535	895	1,605

NOTES:

- (1) Upon prolonged exposure to temperatures above 800°F, the carbide phase of steel may be converted to graphite. Permissible, but not recommended for prolonged use above 800°F.
- (2) Not to be used over 850°F.
- (3) Leded grades shall not be used where welded or in any application above 500°F.
- (4) For service temperatures above 850°F, it is recommended that killed steels containing not less than 0.10% residual silicon be used.
- (5) Not to be used over 700°F.

(17)

**Table VII-2-1.5 Ratings for Group 1.5 Materials**

A182 Gr. F1 (1)		A204 Gr. B (1)			A691 Gr. CM-70 (1)			
A204 Gr. A (1)		<b>A — Standard Class</b>						
Temperature, °F	Working Pressures by Class, psig							
	150	300	600	900	1500	2500	4500	
-20 to 100	265	695	1,395	2,090	3,480	5,805	10,445	
200	260	695	1,395	2,090	3,480	5,805	10,445	
300	230	685	1,375	2,060	3,435	5,725	10,305	
400	200	660	1,325	1,985	3,310	5,520	9,935	
500	170	640	1,285	1,925	3,210	5,350	9,625	
600	140	605	1,210	1,815	3,025	5,040	9,070	
650	125	590	1,175	1,765	2,940	4,905	8,825	
700	110	570	1,135	1,705	2,840	4,730	8,515	
750	95	530	1,065	1,595	2,660	4,430	7,970	
800	80	510	1,015	1,525	2,540	4,230	7,610	
850	65	485	975	1,460	2,435	4,060	7,305	
900	50	450	900	1,350	2,245	3,745	6,740	
950	35	280	560	845	1,405	2,345	4,215	
1,000	20	165	330	495	825	1,370	2,470	
		<b>B — Special Class</b>						
Temperature, °F	Working Pressure by Class, psig							
	150	300	600	900	1500	2500	4500	
-20 to 100	265	695	1,395	2,090	3,480	5,805	10,445	
200	265	695	1,395	2,090	3,480	5,805	10,445	
300	265	695	1,395	2,090	3,480	5,805	10,445	
400	265	695	1,395	2,090	3,480	5,805	10,445	
500	265	695	1,395	2,090	3,480	5,805	10,445	
600	265	695	1,395	2,090	3,480	5,805	10,445	
650	265	695	1,395	2,090	3,480	5,805	10,445	
700	265	695	1,395	2,090	3,480	5,805	10,445	
750	265	695	1,395	2,090	3,480	5,805	10,445	
800	265	695	1,395	2,090	3,480	5,805	10,445	
850	260	680	1,355	2,030	3,385	5,645	10,160	
900	225	585	1,175	1,760	2,935	4,895	8,805	
950	135	350	705	1,055	1,755	2,930	5,270	
1,000	80	205	410	615	1,030	1,715	3,085	

NOTE: (1) Upon prolonged exposure to temperatures above 875°F, the carbide phase of carbon-molybdenum steel may be converted to graphite. Permissible, but not recommended for prolonged use above 875°F.

Table VII-2-1.6 Ratings for Group 1.6 Materials

A387 Gr. 2 Cl. 1	A387 Gr. 2 Cl. 2	A691 Gr. ½Cr					
A — Standard Class							
Temperature, °F	Working Pressures by Class, psig						
	150	300	600	900	1500	2500	4500
-20 to 100	225	590	1,180	1,770	2,945	4,910	8,840
200	225	590	1,180	1,770	2,945	4,910	8,840
300	225	590	1,180	1,770	2,945	4,910	8,840
400	200	590	1,180	1,770	2,945	4,910	8,840
500	170	575	1,150	1,720	2,870	4,785	8,610
600	140	555	1,110	1,665	2,775	4,630	8,330
650	125	545	1,090	1,635	2,725	4,545	8,175
700	110	535	1,070	1,605	2,675	4,455	8,025
750	95	525	1,045	1,570	2,615	4,355	7,840
800	80	510	1,015	1,525	2,540	4,230	7,610
850	65	485	975	1,460	2,435	4,060	7,305
900	50	450	900	1,350	2,245	3,745	6,740
950	35	315	630	945	1,575	2,630	4,730
1,000	20	200	405	605	1,010	1,685	3,035
B — Special Class							
Temperature, °F	Working Pressure by Class, psig						
	150	300	600	900	1500	2500	4500
-20 to 100	225	590	1,180	1,770	2,945	4,910	8,840
200	225	590	1,180	1,770	2,945	4,910	8,840
300	225	590	1,180	1,770	2,945	4,910	8,840
400	225	590	1,180	1,770	2,945	4,910	8,840
500	225	590	1,180	1,770	2,945	4,910	8,840
600	225	590	1,180	1,770	2,945	4,910	8,840
650	225	590	1,180	1,770	2,945	4,910	8,840
700	225	590	1,180	1,770	2,945	4,910	8,840
750	225	590	1,180	1,770	2,945	4,910	8,840
800	225	590	1,180	1,770	2,945	4,910	8,840
850	225	590	1,180	1,770	2,945	4,910	8,840
900	225	590	1,180	1,770	2,945	4,910	8,840
950	150	395	790	1,185	1,970	3,285	5,915
1,000	95	255	505	760	1,265	2,105	3,795

Table VII-2-1.7 Ratings for Group 1.7 Materials

A182 Gr. F2 (1)	A217 Gr. WC4 (1)–(3)		A217 Gr. WC5 (2)		A691 Gr. CM-75		
A — Standard Class							
Temperature, °F	Working Pressures by Class, psig						
	150	300	600	900	1500	2500	4500
–20 to 100	290	750	1,500	2,250	3,750	6,250	11,250
200	260	750	1,500	2,250	3,750	6,250	11,250
300	230	730	1,455	2,185	3,640	6,070	10,925
400	200	705	1,410	2,115	3,530	5,880	10,585
500	170	665	1,330	1,995	3,325	5,540	9,965
600	140	605	1,210	1,815	3,025	5,040	9,070
650	125	590	1,175	1,765	2,940	4,905	8,825
700	110	570	1,135	1,705	2,840	4,730	8,515
750	95	530	1,065	1,595	2,660	4,430	7,970
800	80	510	1,015	1,525	2,540	4,230	7,610
850	65	485	975	1,460	2,435	4,060	7,305
900	50	450	900	1,350	2,245	3,745	6,740
950	35	315	630	945	1,575	2,630	4,730
1,000	20	200	405	605	1,010	1,685	3,035
1,050	20 (4)	160	315	475	790	1,315	2,365
B — Special Class							
Temperature, °F	Working Pressure by Class, psig						
	150	300	600	900	1500	2500	4500
–20 to 100	290	750	1,500	2,250	3,750	6,250	11,250
200	290	750	1,500	2,250	3,750	6,250	11,250
300	290	750	1,500	2,250	3,750	6,250	11,250
400	290	750	1,500	2,250	3,750	6,250	11,250
500	290	750	1,500	2,250	3,750	6,250	11,250
600	290	750	1,500	2,250	3,750	6,250	11,250
650	290	750	1,500	2,250	3,750	6,250	11,250
700	280	735	1,465	2,200	3,665	6,110	10,995
750	280	730	1,460	2,185	3,645	6,070	10,930
800	275	720	1,440	2,160	3,600	6,000	10,800
850	260	680	1,355	2,030	3,385	5,645	10,160
900	230	600	1,200	1,800	3,000	5,000	9,000
950	150	395	790	1,185	1,970	3,285	5,915
1,000	95	255	505	760	1,265	2,105	3,795
1,050	75	195	395	590	985	1,645	2,955

## NOTES:

(1) Not to be used over 1,000°F.

(2) Use normalized and tempered material only.

(3) The deliberate addition of any element not listed in ASTM A217, Table 1 is prohibited, except that calcium (Ca) and manganese (Mn) may be added for deoxidation.

(4) For welding-end valves only. Class 150 flanged-end valves terminate at 1,000°F.

Table VII-2-1.8 Ratings for Group 1.8 Materials

A335 Gr. P22 (1)	A387 Gr. 11 Cl. 1 (1)	A387 Gr. 22 Cl. 1 (1)	A691 Gr. 2¼CR (1)				
A369 Gr. FP22 (1)	A387 Gr. 12 Cl. 2 (1)	A691 Gr. 1¼CR (1)					
A — Standard Class							
Temperature, °F	Working Pressures by Class, psig						
	150	300	600	900	1500	2500	4500
-20 to 100	235	615	1,235	1,850	3,085	5,145	9,255
200	220	575	1,150	1,730	2,880	4,800	8,640
300	215	560	1,120	1,680	2,800	4,665	8,395
400	200	555	1,105	1,660	2,765	4,610	8,300
500	170	555	1,105	1,660	2,765	4,610	8,300
600	140	555	1,105	1,660	2,765	4,610	8,300
650	125	555	1,105	1,660	2,765	4,610	8,300
700	110	545	1,085	1,630	2,715	4,525	8,145
750	95	530	1,065	1,595	2,660	4,430	7,970
800	80	510	1,015	1,525	2,540	4,230	7,610
850	65	485	975	1,460	2,435	4,060	7,305
900	50	450	900	1,350	2,245	3,745	6,740
950	35	320	640	955	1,595	2,655	4,785
1,000	20	215	430	650	1,080	1,800	3,240
1,050	20 (2)	145	290	430	720	1,200	2,160
1,100	20 (2)	95	190	290	480	800	1,440
1,150	20 (2)	60	125	185	310	515	925
1,200	15 (2)	40	75	115	190	315	565
B — Special Class							
Temperature, °F	Working Pressure by Class, psig						
	150	300	600	900	1500	2500	4500
-20 to 100	245	645	1,285	1,930	3,215	5,355	9,645
200	245	640	1,285	1,925	3,210	5,350	9,625
300	240	625	1,245	1,870	3,120	5,195	9,355
400	240	625	1,245	1,870	3,120	5,195	9,355
500	240	625	1,245	1,870	3,120	5,195	9,355
600	240	625	1,245	1,870	3,120	5,195	9,355
650	240	625	1,245	1,870	3,120	5,195	9,355
700	240	625	1,245	1,870	3,120	5,195	9,355
750	240	625	1,245	1,870	3,120	5,195	9,355
800	240	625	1,245	1,870	3,120	5,195	9,355
850	240	625	1,245	1,870	3,120	5,195	9,355
900	225	585	1,165	1,750	2,915	4,855	8,745
950	155	400	795	1,195	1,995	3,320	5,980
1,000	105	270	540	810	1,350	2,250	4,050
1,050	70	180	360	540	900	1,500	2,700
1,100	45	120	240	360	600	1,000	1,800
1,150	30	75	155	230	385	645	1,155
1,200	20	45	95	140	235	395	705

**Table VII-2-1.8 Ratings for Group 1.8 Materials (Cont'd)**

---

NOTES:

- (1) Permissible, but not recommended for prolonged use above 1,100°F.
- (2) Flanged-end valve ratings terminate at 1,000°F.

**Table VII-2-1.9 Ratings for Group 1.9 Materials**

A182 Gr. F11 Cl. 2 (1), (2)	A217 Gr. WC6 (1), (3), (4)		A387 Gr. 11 Cl. 2 (2)		A739 Gr. B11 (2)		
<b>A — Standard Class</b>							
Temperature, °F	Working Pressures by Class, psig						
	150	300	600	900	1500	2500	4500
-20 to 100	290	750	1,500	2,250	3,750	6,250	11,250
200	260	750	1,500	2,250	3,750	6,250	11,250
300	230	720	1,445	2,165	3,610	6,015	10,830
400	200	695	1,385	2,080	3,465	5,775	10,400
500	170	665	1,330	1,995	3,325	5,540	9,965
600	140	605	1,210	1,815	3,025	5,040	9,070
650	125	590	1,175	1,765	2,940	4,905	8,825
700	110	570	1,135	1,705	2,840	4,730	8,515
750	95	530	1,065	1,595	2,660	4,430	7,970
800	80	510	1,015	1,525	2,540	4,230	7,610
850	65	485	975	1,460	2,435	4,060	7,305
900	50	450	900	1,350	2,245	3,745	6,740
950	35	320	640	955	1,595	2,655	4,785
1,000	20	215	430	650	1,080	1,800	3,240
1,050	20 (5)	145	290	430	720	1,200	2,160
1,100	20 (5)	95	190	290	480	800	1,440
1,150	20 (5)	65	130	195	325	545	975
1,200	15 (5)	40	80	125	205	345	615
<b>B — Special Class</b>							
Temperature, °F	Working Pressure by Class, psig						
	150	300	600	900	1500	2500	4500
-20 to 100	290	750	1,500	2,250	3,750	6,250	11,250
200	290	750	1,500	2,250	3,750	6,250	11,250
300	290	750	1,500	2,250	3,750	6,250	11,250
400	290	750	1,500	2,250	3,750	6,250	11,250
500	290	750	1,500	2,250	3,750	6,250	11,250
600	290	750	1,500	2,250	3,750	6,250	11,250
650	290	750	1,500	2,250	3,750	6,250	11,250
700	280	735	1,465	2,200	3,665	6,110	10,995
750	280	730	1,460	2,185	3,645	6,070	10,930
800	275	720	1,440	2,160	3,600	6,000	10,800
850	260	680	1,355	2,030	3,385	5,645	10,160
900	225	585	1,175	1,760	2,935	4,895	8,805
950	155	400	795	1,195	1,995	3,320	5,980
1,000	105	270	540	810	1,350	2,250	4,050
1,050	70	180	360	540	900	1,500	2,700
1,100	45	120	240	360	600	1,000	1,800
1,150	30	80	165	245	405	680	1,220
1,200	20	50	105	155	255	430	770

NOTES:

(1) Use normalized and tempered material only.

**Table VII-2-1.9 Ratings for Group 1.9 Materials (Cont'd)**

---

NOTES (Cont'd):

- (2) Permissible, but not recommended for prolonged use above 1,100°F.
- (3) Not to be used over 1,100°F.
- (4) The deliberate addition of any element not listed in ASTM A217, Table 1 is prohibited, except that calcium (Ca) and manganese (Mn) may be added for deoxidation.
- (5) Flanged-end valve ratings terminate at 1,000°F.



(17)

**Table VII-2-1.10 Ratings for Group 1.10 Materials**

A182 Gr. F22 Cl. 3 (1)	A217 Gr. WC9 (2), (3), (4)			A387 Gr. 22 Cl. 2 (1)		A739 Gr. B22 (2)	
<b>A — Standard Class</b>							
Temperature, °F	Working Pressures by Class, psig						
	150	300	600	900	1500	2500	4500
-20 to 100	290	750	1,500	2,250	3,750	6,250	11,250
200	260	750	1,500	2,250	3,750	6,250	11,250
300	230	730	1,455	2,185	3,640	6,070	10,925
400	200	705	1,410	2,115	3,530	5,880	10,585
500	170	665	1,330	1,995	3,325	5,540	9,965
600	140	605	1,210	1,815	3,025	5,040	9,070
650	125	590	1,175	1,765	2,940	4,905	8,825
700	110	570	1,135	1,705	2,840	4,730	8,515
750	95	530	1,065	1,595	2,660	4,430	7,970
800	80	510	1,015	1,525	2,540	4,230	7,610
850	65	485	975	1,460	2,435	4,060	7,305
900	50	450	900	1,350	2,245	3,745	6,740
950	35	385	775	1,160	1,930	3,220	5,795
1,000	20	265	535	800	1,335	2,230	4,010
1,050	20 (5)	175	350	525	875	1,455	2,625
1,100	20 (5)	110	220	330	550	915	1,645
1,150	20 (5)	70	135	205	345	570	1,030
1,200	15 (5)	40	80	125	205	345	615
<b>B — Special Class</b>							
Temperature, °F	Working Pressure by Class, psig						
	150	300	600	900	1500	2500	4500
-20 to 100	290	750	1,500	2,250	3,750	6,250	11,250
200	290	750	1,500	2,250	3,750	6,250	11,250
300	285	740	1,480	2,220	3,695	6,160	11,090
400	280	730	1,455	2,185	3,640	6,065	10,915
500	280	725	1,450	2,175	3,620	6,035	10,865
600	275	720	1,440	2,165	3,605	6,010	10,815
650	275	715	1,430	2,145	3,580	5,965	10,735
700	270	705	1,415	2,120	3,535	5,895	10,605
750	270	705	1,415	2,120	3,535	5,895	10,605
800	270	705	1,415	2,120	3,535	5,895	10,605
850	260	680	1,355	2,030	3,385	5,645	10,160
900	230	600	1,200	1,800	3,000	5,000	9,000
950	180	470	945	1,415	2,360	3,930	7,070
1,000	130	335	670	1,005	1,670	2,785	5,015
1,050	85	220	435	655	1,095	1,820	3,280
1,100	55	135	275	410	685	1,145	2,055
1,150	35	85	170	255	430	715	1,285
1,200	20	50	105	155	255	430	770

NOTES:

(1) Permissible, but not recommended for prolonged use above 1,100°F.

(17)

**Table VII-2-1.10 Ratings for Group 1.10 Materials (Cont'd)**

---

NOTES (Cont'd):

(2) Use normalized and tempered material only.

(3) Not to be used over 1,100°F.

(4) The deliberate addition of any element not listed in ASTM A217, Table 1 is prohibited, except that calcium (Ca) and manganese (Mn) may be added for deoxidation.

(5) Flanged-end valve ratings terminate at 1,000°F.

**Table VII-2-1.11 Ratings for Group 1.11 Materials**

A182 Gr. F21 (1)	A302 Gr. A (2)	A302 Gr. C (2)	A387 Gr. 21 Cl. 2 (1)
A204 Gr. C (4)	A302 Gr. B (2)	A302 Gr. D (2)	A537 Cl. 2 (3)

**A — Standard Class**

Temperature, °F	Working Pressures by Class, psig						
	150	300	600	900	1500	2500	4500
-20 to 100	290	750	1,500	2,250	3,750	6,250	11,250
200	260	750	1,500	2,250	3,750	6,250	11,250
300	230	730	1,455	2,185	3,640	6,070	10,925
400	200	705	1,410	2,115	3,530	5,880	10,585
500	170	665	1,330	1,995	3,325	5,540	9,965
600	140	605	1,210	1,815	3,025	5,040	9,070
650	125	590	1,175	1,765	2,940	4,905	8,825
700	110	570	1,135	1,705	2,840	4,730	8,515
750	95	530	1,065	1,595	2,660	4,430	7,970
800	80	510	1,015	1,525	2,540	4,230	7,610
850	65	485	975	1,460	2,435	4,060	7,305
900	50	450	900	1,345	2,245	3,745	6,735
950	35	280	560	845	1,405	2,345	4,215
1,000	20	165	330	495	825	1,370	2,470
1,050	20 (5)	165	330	495	825	1,370	2,470
1,100	20 (5)	110	220	330	550	915	1,645
1,150	20 (5)	80	165	245	410	685	1,235
1,200	15 (5)	45	90	135	225	370	670

**B — Special Class**

Temperature, °F	Working Pressure by Class, psig						
	150	300	600	900	1500	2500	4500
-20 to 100	290	750	1,500	2,250	3,750	6,250	11,250
200	290	750	1,500	2,250	3,750	6,250	11,250
300	290	750	1,500	2,250	3,750	6,250	11,250
400	290	750	1,500	2,250	3,750	6,250	11,250
500	290	750	1,500	2,250	3,750	6,250	11,250
600	290	750	1,500	2,250	3,750	6,250	11,250
650	290	750	1,500	2,250	3,750	6,250	11,250
700	280	735	1,465	2,200	3,665	6,110	10,995
750	280	730	1,460	2,185	3,645	6,070	10,930
800	275	720	1,440	2,160	3,600	6,000	10,800
850	260	680	1,355	2,030	3,385	5,645	10,160
900	215	560	1,125	1,685	2,805	4,680	8,420
950	135	350	705	1,055	1,755	2,930	5,270
1,000	80	205	410	615	1,030	1,715	3,085
1,050	80	205	410	615	1,030	1,715	3,085
1,100	55	135	275	410	685	1,145	2,055
1,150	40	105	205	310	515	855	1,545
1,200	20	55	110	165	280	465	835

**Table VII-2-1.11 Ratings for Group 1.11 Materials (Cont'd)**

---

NOTES:

- (1) Permissible, but not recommended for prolonged use above 1,100°F.
- (2) Upon prolonged exposure to temperatures above 875°F, the carbide phase of carbon-molybdenum steel may be converted to graphite. Permissible, but not recommended for prolonged use above 875°F.
- (3) Not to be used over 700°F.
- (4) Upon prolonged exposure to temperatures above 875°F, the carbide phase of steel may be converted to graphite. Permissible, but not recommended for prolonged use above 875°F.
- (5) Flanged-end valve ratings terminate at 1,000°F.

**Table VII-2-1.12 Ratings for Group 1.12 Materials**

A335 Gr. P5	A369 Gr. FP5	A387 Gr. 5 Cl. 2			A691 Gr. 5CR		
A335 Gr. P5b	A387 Gr. 5 Cl. 1						
<b>A — Standard Class</b>							
Temperature, °F	Working Pressures by Class, psig						
	150	300	600	900	1500	2500	4500
-20 to 100	235	615	1,235	1,850	3,085	5,145	9,255
200	215	555	1,115	1,670	2,785	4,645	8,360
300	205	535	1,075	1,610	2,685	4,475	8,055
400	200	530	1,060	1,590	2,655	4,425	7,960
500	170	525	1,055	1,580	2,635	4,390	7,900
600	140	520	1,035	1,555	2,590	4,320	7,775
650	125	510	1,025	1,535	2,560	4,270	7,685
700	110	505	1,010	1,510	2,520	4,200	7,560
750	95	490	985	1,475	2,460	4,095	7,375
800	80	475	950	1,425	2,375	3,960	7,130
850	65	455	915	1,370	2,285	3,805	6,850
900	50	375	745	1,120	1,870	3,115	5,605
950	35	275	550	825	1,370	2,285	4,115
1,000	20	200	400	595	995	1,655	2,985
1,050	20 (1)	145	290	430	720	1,200	2,160
1,100	20 (1)	100	200	300	495	830	1,490
1,150	20 (1)	60	125	185	310	515	925
1,200	15 (1)	35	70	105	170	285	515
<b>B — Special Class</b>							
Temperature, °F	Working Pressure by Class, psig						
	150	300	600	900	1500	2500	4500
-20 to 100	245	645	1,285	1,930	3,215	5,355	9,645
200	245	640	1,285	1,925	3,210	5,350	9,625
300	240	625	1,245	1,870	3,115	5,190	9,340
400	235	620	1,235	1,855	3,090	5,150	9,275
500	235	615	1,230	1,850	3,080	5,135	9,240
600	235	610	1,215	1,825	3,040	5,065	9,115
650	230	600	1,195	1,795	2,990	4,980	8,970
700	225	585	1,170	1,755	2,925	4,875	8,775
750	225	585	1,170	1,755	2,925	4,875	8,775
800	225	585	1,170	1,755	2,925	4,875	8,775
850	225	585	1,170	1,755	2,925	4,875	8,775
900	180	465	935	1,400	2,335	3,895	7,005
950	130	345	685	1,030	1,715	2,855	5,145
1,000	95	250	495	745	1,245	2,070	3,730
1,050	70	180	360	540	900	1,500	2,700
1,100	50	125	250	375	620	1,035	1,865
1,150	30	75	155	230	385	645	1,155
1,200	15	45	85	130	215	355	645

**Table VII-2-1.12 Ratings for Group 1.12 Materials (Cont'd)**

---

NOTE: (1) Flanged-end valve ratings terminate at 1,000°F.

Table VII-2-1.13 Ratings for Group 1.13 Materials

A182 Gr. F5a		A217 Gr. C5 (1), (2)					
A — Standard Class							
Temperature, °F	Working Pressures by Class, psig						
	150	300	600	900	1500	2500	4500
-20 to 100	290	750	1,500	2,250	3,750	6,250	11,250
200	260	750	1,500	2,250	3,750	6,250	11,250
300	230	730	1,455	2,185	3,640	6,070	10,925
400	200	705	1,410	2,115	3,530	5,880	10,585
500	170	665	1,330	1,995	3,325	5,540	9,965
600	140	605	1,210	1,815	3,025	5,040	9,070
650	125	590	1,175	1,765	2,940	4,905	8,825
700	110	570	1,135	1,705	2,840	4,730	8,515
750	95	530	1,065	1,595	2,660	4,430	7,970
800	80	510	1,015	1,525	2,540	4,230	7,610
850	65	485	975	1,460	2,435	4,060	7,305
900	50	375	745	1,120	1,870	3,115	5,605
950	35	275	550	825	1,370	2,285	4,115
1,000	20	200	400	595	995	1,655	2,985
1,050	20 (3)	145	290	430	720	1,200	2,160
1,100	20 (3)	100	200	300	495	830	1,490
1,150	20 (3)	60	125	185	310	515	925
1,200	15 (3)	35	70	105	170	285	515
B — Special Class							
Temperature, °F	Working Pressure by Class, psig						
	150	300	600	900	1500	2500	4500
-20 to 100	290	750	1,500	2,250	3,750	6,250	11,250
200	290	750	1,500	2,250	3,750	6,250	11,250
300	290	750	1,500	2,250	3,750	6,250	11,250
400	290	750	1,500	2,250	3,750	6,250	11,250
500	290	750	1,500	2,250	3,750	6,250	11,250
600	290	750	1,500	2,250	3,750	6,250	11,250
650	290	750	1,500	2,250	3,750	6,250	11,250
700	280	735	1,465	2,200	3,665	6,110	10,995
750	280	730	1,460	2,185	3,645	6,070	10,930
800	275	720	1,440	2,160	3,600	6,000	10,800
850	260	615	1,225	1,840	3,065	5,105	9,195
900	230	465	935	1,400	2,335	3,895	7,005
950	170	345	685	1,030	1,715	2,855	5,145
1,000	125	250	495	745	1,245	2,070	3,730
1,050	90	180	360	540	900	1,500	2,700
1,100	60	125	250	375	620	1,035	1,865
1,150	40	75	155	230	385	645	1,155
1,200	20	45	85	130	215	355	645

## NOTES:

(1) Use normalized and tempered material only.

**Table VII-2-1.13 Ratings for Group 1.13 Materials (Cont'd)**

---

NOTES (Cont'd):

- (2) The deliberate addition of any element not listed in ASTM A217, Table 1 is prohibited, except that calcium (Ca) and manganese (Mn) may be added for deoxidation.
- (3) Flanged-end valve ratings terminate at 1,000°F.



Table VII-2-1.14 Ratings for Group 1.14 Materials

A182 Gr. F9		A217 Gr. C12 (1), (2)					
A — Standard Class							
Temperature, °F	Working Pressures by Class, psig						
	150	300	600	900	1500	2500	4500
-20 to 100	290	750	1,500	2,250	3,750	6,250	11,250
200	260	750	1,500	2,250	3,750	6,250	11,250
300	230	730	1,455	2,185	3,640	6,070	10,925
400	200	705	1,410	2,115	3,530	5,880	10,585
500	170	665	1,330	1,995	3,325	5,540	9,965
600	140	605	1,210	1,815	3,025	5,040	9,070
650	125	590	1,175	1,765	2,940	4,905	8,825
700	110	570	1,135	1,705	2,840	4,730	8,515
750	95	530	1,065	1,595	2,660	4,430	7,970
800	80	510	1,015	1,525	2,540	4,230	7,610
850	65	485	975	1,460	2,435	4,060	7,305
900	50	450	900	1,350	2,245	3,745	6,740
950	35	375	755	1,130	1,885	3,145	5,655
1,000	20	255	505	760	1,270	2,115	3,805
1,050	20 (3)	170	345	515	855	1,430	2,570
1,100	20 (3)	115	225	340	565	945	1,695
1,150	20 (3)	75	150	225	375	630	1,130
1,200	20 (3)	50	105	155	255	430	770
B — Special Class							
Temperature, °F	Working Pressure by Class, psig						
	150	300	600	900	1500	2500	4500
-20 to 100	290	750	1,500	2,250	3,750	6,250	11,250
200	290	750	1,500	2,250	3,750	6,250	11,250
300	290	750	1,500	2,250	3,750	6,250	11,250
400	290	750	1,500	2,250	3,750	6,250	11,250
500	290	750	1,500	2,250	3,750	6,250	11,250
600	290	750	1,500	2,250	3,750	6,250	11,250
650	290	750	1,500	2,250	3,750	6,250	11,250
700	280	735	1,465	2,200	3,665	6,110	10,995
750	280	730	1,460	2,185	3,645	6,070	10,930
800	275	720	1,440	2,160	3,600	6,000	10,800
850	260	680	1,355	2,030	3,385	5,645	10,160
900	230	600	1,200	1,800	3,000	5,000	9,000
950	180	470	945	1,415	2,355	3,930	7,070
1,000	120	315	635	950	1,585	2,645	4,755
1,050	80	215	430	645	1,070	1,785	3,215
1,100	55	140	285	425	705	1,180	2,120
1,150	35	95	190	285	470	785	1,415
1,200	25	65	130	195	320	535	965

## NOTES:

(1) Use normalized and tempered material only.

**Table VII-2-1.14 Ratings for Group 1.14 Materials (Cont'd)**

---

NOTES (Cont'd):

- (2) The deliberate addition of any element not listed in ASTM A217, Table 1 is prohibited, except that calcium (Ca) and manganese (Mn) may be added for deoxidation.
- (3) Flanged-end valve ratings terminate at 1,000°F.

**Table VII-2-1.15 Ratings for Group 1.15 Materials**

A182 Gr. F91	A217 Gr. C12A (1)		A335 Gr. P91		A387 Gr. 91 Cl. 2		
<b>A — Standard Class</b>							
Temperature, °F	Working Pressures by Class, psig						
	150	300	600	900	1500	2500	4500
-20 to 100	290	750	1,500	2,250	3,750	6,250	11,250
200	260	750	1,500	2,250	3,750	6,250	11,250
300	230	730	1,455	2,185	3,640	6,070	10,925
400	200	705	1,410	2,115	3,530	5,880	10,585
500	170	665	1,330	1,995	3,325	5,540	9,965
600	140	605	1,210	1,815	3,025	5,040	9,070
650	125	590	1,175	1,765	2,940	4,905	8,825
700	110	570	1,135	1,705	2,840	4,730	8,515
750	95	530	1,065	1,595	2,660	4,430	7,970
800	80	510	1,015	1,525	2,540	4,230	7,610
850	65	485	975	1,460	2,435	4,060	7,305
900	50	450	900	1,350	2,245	3,745	6,740
950	35	385	775	1,160	1,930	3,220	5,795
1,000	20	365	725	1,090	1,820	3,030	5,450
1,050	20 (2)	360	720	1,080	1,800	3,000	5,400
1,100	20 (2)	300	605	905	1,510	2,515	4,525
1,150	20 (2)	225	445	670	1,115	1,855	3,345
1,200	20 (2)	145	290	430	720	1,200	2,160
<b>B — Special Class</b>							
Temperature, °F	Working Pressure by Class, psig						
	150	300	600	900	1500	2500	4500
-20 to 100	290	750	1,500	2,250	3,750	6,250	11,250
200	290	750	1,500	2,250	3,750	6,250	11,250
300	290	750	1,500	2,250	3,750	6,250	11,250
400	290	750	1,500	2,250	3,750	6,250	11,250
500	290	750	1,500	2,250	3,750	6,250	11,250
600	290	750	1,500	2,250	3,750	6,250	11,250
650	290	750	1,500	2,250	3,750	6,250	11,250
700	280	735	1,465	2,200	3,665	6,110	10,995
750	280	730	1,460	2,185	3,645	6,070	10,930
800	275	720	1,440	2,160	3,600	6,000	10,800
850	260	680	1,355	2,030	3,385	5,645	10,160
900	230	600	1,200	1,800	3,000	5,000	9,000
950	180	470	945	1,415	2,360	3,930	7,070
1,000	160	420	840	1,260	2,105	3,505	6,310
1,050	160	420	840	1,260	2,105	3,505	6,310
1,100	145	375	755	1,130	1,885	3,145	5,655
1,150	105	280	555	835	1,395	2,320	4,180
1,200	70	180	360	540	900	1,500	2,700

**Table VII-2-1.15 Ratings for Group 1.15 Materials (Cont'd)**

---

NOTES:

- (1) The deliberate addition of any element not listed in ASTM A217, Table 1 is prohibited, except that calcium (Ca) and manganese (Mn) may be added for deoxidation.
- (2) Flanged-end valve ratings terminate at 1,000°F.

**Table VII-2-1.16 Ratings for Group 1.16 Materials**

A335 Gr. P1 (1), (2)	A335 Gr. P12 (3)	A369 Gr. FP11 (3)	A387 Gr. 12 Cl. 1 (3)
A335 Gr. P11 (3)	A369 Gr. FP1 (1), (2)	A369 Gr. FP12 (3)	A691 Gr. 1CR (3), (4)

**A — Standard Class**

Temperature, °F	Working Pressures by Class, psig						
	150	300	600	900	1500	2500	4500
-20 to 100	225	590	1,180	1,770	2,945	4,910	8,840
200	220	570	1,140	1,710	2,850	4,750	8,545
300	205	540	1,080	1,625	2,705	4,510	8,115
400	200	520	1,040	1,560	2,600	4,335	7,805
500	170	500	1,005	1,505	2,510	4,185	7,530
600	140	485	965	1,450	2,415	4,030	7,250
650	125	475	950	1,425	2,375	3,960	7,130
700	110	465	930	1,395	2,325	3,875	6,975
750	95	455	915	1,370	2,285	3,805	6,850
800	80	445	890	1,335	2,220	3,705	6,665
850	65	430	865	1,295	2,160	3,600	6,480
900	50	420	840	1,260	2,100	3,495	6,295
950	35	280	560	845	1,405	2,345	4,215
1,000	20	165	330	495	825	1,370	2,470
1,050	20 (5)	145	290	430	720	1,200	2,160
1,100	20 (5)	95	190	290	480	800	1,440
1,150	20 (5)	60	125	185	310	515	925
1,200	15 (5)	40	75	115	190	315	565

**B — Special Class**

Temperature, °F	Working Pressure by Class, psig						
	150	300	600	900	1500	2500	4500
-20 to 100	225	590	1,180	1,770	2,945	4,910	8,840
200	220	580	1,155	1,735	2,895	4,820	8,680
300	215	565	1,135	1,700	2,835	4,725	8,500
400	215	565	1,135	1,700	2,835	4,725	8,500
500	215	565	1,135	1,700	2,835	4,725	8,500
600	215	565	1,135	1,700	2,835	4,725	8,500
650	215	565	1,135	1,700	2,835	4,725	8,500
700	215	565	1,135	1,700	2,835	4,725	8,500
750	215	565	1,135	1,700	2,835	4,725	8,500
800	215	565	1,135	1,700	2,835	4,725	8,500
850	215	565	1,135	1,700	2,835	4,725	8,500
900	215	560	1,120	1,680	2,800	4,665	8,395
950	135	350	705	1,055	1,755	2,930	5,270
1,000	80	205	410	615	1,030	1,715	3,085
1,050	75	195	385	580	965	1,605	2,895
1,100	45	120	240	360	600	1,000	1,800
1,150	30	75	155	230	385	645	1,155
1,200	20	45	95	140	235	395	705

**Table VII-2-1.16 Ratings for Group 1.16 Materials (Cont'd)**

---

NOTES:

- (1) Upon prolonged exposure to temperatures above 875°F, the carbide phase of steel may be converted to graphite. Permissible but not recommended for prolonged usage above 875°F.
- (2) Not to be used over 1,000°F.
- (3) Permissible but not recommended for prolonged usage above 1,100°F.
- (4) Use normalized and tempered material only.
- (5) Flanged-end valve ratings terminate at 1,000°F.

**Table VII-2-1.17 Ratings for Group 1.17 Materials**

A182 Gr. F12 Cl. 2 (1), (2)		A182 Gr. F5					
A — Standard Class							
Temperature, °F	Working Pressures by Class, psig						
	150	300	600	900	1500	2500	4500
-20 to 100	290	750	1,500	2,250	3,750	6,250	11,250
200	260	735	1,470	2,210	3,680	6,135	11,040
300	230	700	1,400	2,100	3,495	5,830	10,490
400	200	670	1,335	2,005	3,345	5,570	10,030
500	170	645	1,290	1,940	3,230	5,385	9,690
600	140	605	1,210	1,815	3,025	5,040	9,070
650	125	590	1,175	1,765	2,940	4,905	8,825
700	110	570	1,135	1,705	2,840	4,730	8,515
750	95	530	1,065	1,595	2,660	4,430	7,970
800	80	510	1,015	1,525	2,540	4,230	7,610
850	65	485	975	1,460	2,435	4,060	7,305
900	50	375	745	1,120	1,870	3,115	5,605
950	35	275	550	825	1,370	2,285	4,115
1,000	20	200	400	595	995	1,655	2,985
1,050	20 (3)	145	290	430	720	1,200	2,160
1,100	20 (3)	95	190	290	480	800	1,440
1,150	20 (3)	60	125	185	310	515	925
1,200	15 (3)	35	70	105	170	285	515
B — Special Class							
Temperature, °F	Working Pressure by Class, psig						
	150	300	600	900	1500	2500	4500
-20 to 100	290	750	1,500	2,250	3,750	6,250	11,250
200	280	735	1,470	2,210	3,680	6,135	11,040
300	275	720	1,440	2,165	3,605	6,010	10,815
400	275	720	1,440	2,165	3,605	6,010	10,815
500	275	720	1,440	2,155	3,595	5,990	10,785
600	270	710	1,415	2,125	3,540	5,900	10,625
650	265	695	1,395	2,090	3,485	5,810	10,460
700	260	685	1,365	2,050	3,415	5,690	10,240
750	260	685	1,365	2,050	3,415	5,690	10,240
800	260	685	1,365	2,050	3,415	5,690	10,240
850	235	615	1,225	1,840	3,065	5,105	9,195
900	180	465	935	1,400	2,335	3,895	7,005
950	130	345	685	1,030	1,715	2,855	5,145
1,000	95	250	495	745	1,245	2,070	3,730
1,050	70	180	360	540	900	1,500	2,700
1,100	45	120	240	360	600	1,000	1,800
1,150	30	75	155	230	385	645	1,155
1,200	15	45	85	130	215	355	645

NOTES:

(1) Use normalized and tempered material only.

**Table VII-2-1.17 Ratings for Group 1.17 Materials (Cont'd)**

---

NOTES (Cont'd):

- (2) Permissible but not recommended for prolonged usage above 1,100°F.
- (3) Flanged-end valve ratings terminate at 1,000°F.



**Table VII-2-1.18 Ratings for Group 1.18 Materials**

A182 Gr. F92 (1)	A335 Gr. P92 (1)		A369 Gr. FP92 (1)				
<b>A — Standard Class</b>							
Temperature, °F	Working Pressures by Class, psig						
	150	300	600	900	1500	2500	4500
-20 to 100	290	750	1,500	2,250	3,750	6,250	11,250
200	260	750	1,500	2,250	3,750	6,250	11,250
300	230	730	1,455	2,185	3,640	6,070	10,925
400	200	705	1,410	2,115	3,530	5,880	10,585
500	170	665	1,330	1,995	3,325	5,540	9,965
600	140	605	1,210	1,815	3,025	5,040	9,070
650	125	590	1,175	1,765	2,940	4,905	8,825
700	110	570	1,135	1,705	2,840	4,730	8,515
750	95	530	1,065	1,595	2,660	4,430	7,970
800	80	510	1,015	1,525	2,540	4,230	7,610
850	65	485	975	1,460	2,435	4,060	7,305
900	50	450	900	1,350	2,245	3,745	6,740
950	35	385	775	1,160	1,930	3,220	5,795
1,000	20	365	725	1,090	1,820	3,030	5,450
1,050	20 (2)	360	720	1,080	1,800	3,000	5,400
1,100	20 (2)	325	645	965	1,610	2,685	4,835
1,150	20 (2)	275	550	825	1,370	2,285	4,115
1,200	20 (2)	190	385	575	960	1,600	2,880
<b>B — Special Class</b>							
Temperature, °F	Working Pressure by Class, psig						
	150	300	600	900	1500	2500	4500
-20 to 100	290	750	1,500	2,250	3,750	6,250	11,250
200	290	750	1,500	2,250	3,750	6,250	11,250
300	290	750	1,500	2,250	3,750	6,250	11,250
400	290	750	1,500	2,250	3,750	6,250	11,250
500	290	750	1,500	2,250	3,750	6,250	11,250
600	290	750	1,500	2,250	3,750	6,250	11,250
650	290	750	1,500	2,250	3,750	6,250	11,250
700	280	735	1,465	2,200	3,665	6,110	10,995
750	280	730	1,460	2,185	3,645	6,070	10,930
800	275	720	1,440	2,160	3,600	6,000	10,800
850	260	680	1,355	2,030	3,385	5,645	10,160
900	230	600	1,200	1,800	3,000	5,000	9,000
950	180	470	945	1,415	2,360	3,930	7,070
1,000	160	420	840	1,260	2,105	3,505	6,310
1,050	160	420	840	1,260	2,105	3,505	6,310
1,100	155	405	805	1,210	2,015	3,360	6,045
1,150	130	345	685	1,030	1,715	2,860	5,145
1,200	90	240	480	720	1,200	2,000	3,600

NOTES:

(1) Application above 1,150°F is limited to tubing of maximum outside diameter of 3½ in.

**Table VII-2-1.18 Ratings for Group 1.18 Materials (Cont'd)**

---

NOTES (Cont'd):

(2) For welding-end valves only. Flanged-end valve ratings terminate at 1,000°F.

**Table VII-2-2.1 Ratings for Group 2.1 Materials**

A182 Gr. F304 (1)	A312 Gr. TP304 (1)	A351 Gr. CF8 (1)	A430 Gr. FP304 (1)
A182 Gr. F304H	A312 Gr. TP304H	A358 Gr. 304 (1)	A430 Gr. FP304H
A240 Gr. 304 (1)	A351 Gr. CF10	A376 Gr. TP304 (1)	A479 Gr. 304 (1)
A240 Gr. 304H	A351 Gr. CF3 (2)	A376 Gr. TP304H	A479 Gr. 304H

**A — Standard Class**

Temperature, °F	Working Pressures by Class, psig						
	150	300	600	900	1500	2500	4500
-20 to 100	275	720	1,440	2,160	3,600	6,000	10,800
200	230	600	1,200	1,800	3,000	5,000	9,000
300	205	540	1,075	1,615	2,690	4,480	8,065
400	190	495	995	1,490	2,485	4,140	7,450
500	170	465	930	1,395	2,330	3,880	6,985
600	140	440	885	1,325	2,210	3,680	6,625
650	125	430	865	1,295	2,160	3,600	6,480
700	110	420	845	1,265	2,110	3,520	6,335
750	95	415	825	1,240	2,065	3,440	6,190
800	80	405	810	1,215	2,030	3,380	6,085
850	65	395	790	1,190	1,980	3,300	5,940
900	50	390	780	1,165	1,945	3,240	5,830
950	35	380	765	1,145	1,910	3,180	5,725
1,000	20	355	710	1,065	1,770	2,950	5,315
1,050	20 (3)	325	650	975	1,630	2,715	4,885
1,100	20 (3)	255	515	770	1,285	2,145	3,855
1,150	20 (3)	205	410	615	1,030	1,715	3,085
1,200	20 (3)	165	330	495	825	1,370	2,470
1,250	20 (3)	135	265	400	670	1,115	2,005
1,300	20 (3)	115	225	340	565	945	1,695
1,350	20 (3)	95	185	280	465	770	1,390
1,400	20 (3)	75	150	225	380	630	1,130
1,450	20 (3)	60	115	175	290	485	875
1,500	15 (3)	40	85	125	205	345	620

**B — Special Class**

Temperature, °F	Working Pressure by Class, psig						
	150	300	600	900	1500	2500	4500
-20 to 100	290	750	1,500	2,250	3,750	6,250	11,250
200	255	670	1,340	2,010	3,350	5,580	10,045
300	230	600	1,200	1,800	3,000	5,000	9,000
400	215	555	1,110	1,665	2,770	4,620	8,315
500	200	520	1,040	1,560	2,600	4,330	7,795
600	190	495	985	1,480	2,465	4,105	7,395
650	185	480	965	1,445	2,410	4,020	7,230
700	180	470	945	1,415	2,355	3,930	7,070
750	175	460	920	1,380	2,305	3,840	6,910
800	175	455	905	1,360	2,265	3,770	6,790
850	170	440	885	1,325	2,210	3,685	6,630

**Table VII-2-2.1 Ratings for Group 2.1 Materials (Cont'd)**

<b>B — Special Class</b>							
<b>Temperature, °F</b>	<b>Working Pressure by Class, psig</b>						
	<b>150</b>	<b>300</b>	<b>600</b>	<b>900</b>	<b>1500</b>	<b>2500</b>	<b>4500</b>
900	165	435	870	1,300	2,170	3,615	6,510
950	165	425	850	1,280	2,130	3,550	6,390
1,000	160	415	830	1,245	2,075	3,460	6,230
1,050	155	405	815	1,220	2,035	3,395	6,105
1,100	125	320	645	965	1,605	2,680	4,820
1,150	100	255	515	770	1,285	2,145	3,855
1,200	80	205	410	615	1,030	1,715	3,085
1,250	65	165	335	500	835	1,395	2,505
1,300	55	140	285	425	705	1,180	2,120
1,350	45	115	230	345	580	965	1,735
1,400	35	95	190	285	470	785	1,415
1,450	30	75	145	220	365	610	1,095
1,500	20	50	105	155	260	430	770

## NOTES:

(1) At temperatures over 1,000°F, use only when the carbon content is 0.04% or higher.

(2) Not to be used over 800°F.

(3) Flanged-end valve ratings terminate at 1,000°F.

(17)

**Table VII-2-2.2 Ratings for Group 2.2 Materials**

A182 Gr. F316 (1)	A312 Gr. TP316 (1)	A351 Gr. CF8A (2)	A376 Gr. TP316 (1)
A182 Gr. F316H	A312 Gr. TP316H	A351 Gr. CF8M (1)	A376 Gr. TP316H
A182 Gr. F317 (1)	A312 Gr. TP317 (1)	A351 Gr. CF10M	A430 Gr. FP316 (1)
A240 Gr. 316 (1)	A351 Gr. CF3A (2)	A351 Gr. CG3M (3)	A430 Gr. FP316H
A240 Gr. 316H	A351 Gr. CF3M (3)	A351 Gr. CG8M (4)	A479 Gr. 316 (1)
A240 Gr. 317 (1)		A358 Gr. 316 (1)	A479 Gr. 316H

**A — Standard Class**

Temperature, °F	Working Pressures by Class, psig						
	150	300	600	900	1500	2500	4500
-20 to 100	275	720	1,440	2,160	3,600	6,000	10,800
200	235	620	1,240	1,860	3,095	5,160	9,290
300	215	560	1,120	1,680	2,795	4,660	8,390
400	195	515	1,025	1,540	2,570	4,280	7,705
500	170	480	955	1,435	2,390	3,980	7,165
600	140	450	900	1,355	2,255	3,760	6,770
650	125	440	885	1,325	2,210	3,680	6,625
700	110	435	870	1,305	2,170	3,620	6,515
750	95	425	855	1,280	2,135	3,560	6,410
800	80	420	845	1,265	2,110	3,520	6,335
850	65	420	835	1,255	2,090	3,480	6,265
900	50	415	830	1,245	2,075	3,460	6,230
950	35	385	775	1,160	1,930	3,220	5,795
1,000	20	365	725	1,090	1,820	3,030	5,450
1,050	20	360	720	1,080	1,800	3,000	5,400
1,100	20 (5)	305	610	915	1,525	2,545	4,575
1,150	20 (5)	235	475	710	1,185	1,970	3,550
1,200	20 (5)	185	370	555	925	1,545	2,775
1,250	20 (5)	145	295	440	735	1,230	2,210
1,300	20 (5)	115	235	350	585	970	1,750
1,350	20 (5)	95	190	290	480	800	1,440
1,400	20 (5)	75	150	225	380	630	1,130
1,450	20 (5)	60	115	175	290	485	875
1,500	15 (5)	40	85	125	205	345	620

**B — Special Class**

Temperature, °F	Working Pressure by Class, psig						
	150	300	600	900	1500	2500	4500
-20 to 100	290	750	1,500	2,250	3,750	6,250	11,250
200	265	690	1,380	2,075	3,455	5,760	10,365
300	240	625	1,250	1,870	3,120	5,200	9,360
400	220	575	1,145	1,720	2,865	4,775	8,600
500	205	535	1,065	1,600	2,665	4,440	7,995
600	195	505	1,005	1,510	2,520	4,195	7,555
650	190	495	985	1,480	2,465	4,105	7,395
700	185	485	970	1,455	2,425	4,040	7,270
750	185	475	955	1,430	2,385	3,975	7,150
800	180	470	945	1,415	2,355	3,930	7,070

(17)

**Table VII-2-2.2 Ratings for Group 2.2 Materials (Cont'd)**

B — Special Class							
Temperature, °F	Working Pressure by Class, psig						
	150	300	600	900	1500	2500	4500
850	180	465	930	1,400	2,330	3,885	6,990
900	180	465	925	1,390	2,315	3,860	6,950
950	175	460	915	1,375	2,290	3,815	6,870
1,000	160	420	840	1,260	2,105	3,505	6,310
1,050	160	420	840	1,260	2,105	3,505	6,310
1,100	145	380	765	1,145	1,905	3,180	5,720
1,150	115	295	590	885	1,480	2,465	4,435
1,200	90	230	465	695	1,155	1,930	3,470
1,250	70	185	370	555	920	1,535	2,765
1,300	55	145	290	435	730	1,215	2,185
1,350	45	120	240	360	600	1,000	1,800
1,400	35	95	190	285	470	785	1,415
1,450	30	75	145	220	365	605	1,095
1,500	20	50	105	155	260	430	770

## NOTES:

- (1) At temperatures over 1,000°F, use only when the carbon content is 0.04% or higher.
- (2) Not to be used over 650°F.
- (3) Not to be used over 850°F.
- (4) Not to be used over 1,000°F.
- (5) Flanged-end valve ratings terminate at 1,000°F.

Table VII-2-2.3 Ratings for Group 2.3 Materials

A182 Gr. F304L (1)	A240 Gr. 304L (1)	A312 Gr. TP316L					
A182 Gr. F316L	A240 Gr. 316L	A479 Gr. 304L (1)					
A182 Gr. F317L	A312 Gr. TP304L (1)	A479 Gr. 316L					
<b>A — Standard Class</b>							
<b>Temperature, °F</b>	<b>Working Pressures by Class, psig</b>						
	<b>150</b>	<b>300</b>	<b>600</b>	<b>900</b>	<b>1500</b>	<b>2500</b>	<b>4500</b>
-20 to 100	230	600	1,200	1,800	3,000	5,000	9,000
200	195	510	1,020	1,535	2,555	4,260	7,670
300	175	455	910	1,370	2,280	3,800	6,840
400	160	420	840	1,260	2,100	3,500	6,300
500	150	395	785	1,180	1,970	3,280	5,905
600	140	370	745	1,115	1,860	3,100	5,580
650	125	365	730	1,095	1,825	3,040	5,470
700	110	360	720	1,080	1,800	3,000	5,400
750	110	355	705	1,060	1,765	2,940	5,290
800	80	345	690	1,035	1,730	2,880	5,185
850	65	340	675	1,015	1,690	2,820	5,075
<b>B — Special Class</b>							
<b>Temperature, °F</b>	<b>Working Pressure by Class, psig</b>						
	<b>150</b>	<b>300</b>	<b>600</b>	<b>900</b>	<b>1500</b>	<b>2500</b>	<b>4500</b>
-20 to 100	255	670	1,340	2,010	3,350	5,580	10,045
200	220	570	1,140	1,710	2,855	4,755	8,560
300	195	510	1,020	1,525	2,545	4,240	7,635
400	180	470	940	1,405	2,345	3,905	7,030
500	170	440	880	1,320	2,195	3,660	6,590
600	160	415	830	1,245	2,075	3,460	6,230
650	155	405	815	1,220	2,035	3,395	6,105
700	155	400	805	1,205	2,010	3,350	6,025
750	150	395	790	1,180	1,970	3,280	5,905
800	150	385	770	1,155	1,930	3,215	5,785
850	145	380	755	1,135	1,890	3,145	5,665

NOTE: (1) Not to be used over 800°F.

(17)

**Table VII-2-2.4 Ratings for Group 2.4 Materials**

A182 Gr. F321 (1)	A312 Gr. TP321 (1)	A376 Gr. TP321 (1)	A430 Gr. FP321H
A182 Gr. F321H (2)	A312 Gr. TP321H	A376 Gr. TP321H	A479 Gr. 321 (1)
A240 Gr. 321 (1)	A358 Gr. 321 (1)	A430 Gr. FP321 (1)	A479 Gr. 321H
A240 Gr. 321H (2)			

**A — Standard Class**

Temperature, °F	Working Pressures by Class, psig						
	150	300	600	900	1500	2500	4500
100	275	720	1,440	2,160	3,600	6,000	10,800
200	250	650	1,295	1,945	3,240	5,400	9,720
300	230	595	1,190	1,785	2,975	4,960	8,930
400	200	550	1,105	1,655	2,760	4,600	8,280
500	170	515	1,030	1,550	2,580	4,300	7,740
600	140	485	975	1,460	2,435	4,060	7,310
650	125	475	950	1,425	2,375	3,960	7,130
700	110	465	930	1,395	2,330	3,880	6,985
750	95	460	915	1,375	2,290	3,820	6,875
800	80	450	900	1,355	2,255	3,760	6,770
850	65	445	895	1,340	2,230	3,720	6,695
900	50	440	885	1,325	2,210	3,680	6,625
950	35	385	775	1,160	1,930	3,220	5,795
1,000	20	365	725	1,090	1,820	3,030	5,450
1,050	20 (3)	360	720	1,080	1,800	3,000	5,400
1,100	20 (3)	310	625	935	1,560	2,600	4,680
1,150	20 (3)	235	475	710	1,185	1,970	3,550
1,200	20 (3)	185	370	555	925	1,545	2,775
1,250	20 (3)	140	280	420	705	1,170	2,110
1,300	20 (3)	110	220	330	550	915	1,645
1,350	20 (3)	85	170	255	430	715	1,285
1,400	20 (3)	65	130	195	325	545	975
1,450	20 (3)	50	105	155	255	430	770
1,500	15 (3)	40	75	115	190	315	565

**B — Special Class**

Temperature, °F	Working Pressure by Class, psig						
	150	300	600	900	1500	2500	4500
-20 to 100	290	750	1,500	2,250	3,750	6,250	11,250
200	275	710	1,425	2,135	3,555	5,930	10,670
300	255	665	1,330	1,995	3,320	5,535	9,965
400	235	615	1,230	1,850	2,080	5,135	9,240
500	220	575	1,150	1,730	2,880	4,800	8,640
600	210	545	1,090	1,630	2,720	4,530	8,155
650	205	530	1,060	1,590	2,650	4,420	7,955
700	200	520	1,040	1,560	2,600	4,330	7,795
750	195	510	1,025	1,535	2,560	4,265	7,675
800	195	505	1,005	1,510	2,520	4,195	7,555
850	190	500	995	1,495	2,490	4,150	7,475



(17) **Table VII-2-2.4 Ratings for Group 2.4 Materials (Cont'd)**

<b>B — Special Class</b>							
<b>Temperature, °F</b>	<b>Working Pressure by Class, psig</b>						
	<b>150</b>	<b>300</b>	<b>600</b>	<b>900</b>	<b>1500</b>	<b>2500</b>	<b>4500</b>
900	190	495	985	1,480	2,465	4,105	7,395
950	180	470	945	1,415	2,360	3,930	7,070
1,000	160	420	840	1,260	2,105	3,505	6,310
1,050	160	420	840	1,260	2,105	3,505	6,310
1,100	150	390	780	1,170	1,950	3,250	5,850
1,150	115	295	590	885	1,480	2,465	4,435
1,200	90	230	465	695	1,155	1,930	3,470
1,250	65	175	350	525	880	1,465	2,635
1,300	55	135	275	410	685	1,145	2,055
1,350	40	105	215	320	535	895	1,605
1,400	30	80	165	245	405	680	1,220
1,450	25	65	130	195	320	535	965
1,500	20	45	95	140	235	395	705

## NOTES:

(1) Not to be used over 1,000°F.

(2) At temperatures over 1,000°F, use only if the material is heat treated by heating to a minimum temperature of 2,000°F.

(3) Flanged-end valve ratings terminate at 1,000°F.

Table VII-2-2.5 Ratings for Group 2.5 Materials

A182 Gr. F347 (1)	A240 Gr. 348 (1)	A358 Gr. 347 (1)	A430 Gr. FP347H
A182 Gr. F347H (2)	A240 Gr. 348H (2)	A376 Gr. TP347 (1)	A479 Gr. 347 (1)
A182 Gr. F348 (1)	A312 Gr. TP347 (1)	A376 Gr. TP347H	A479 Gr. 347H
A182 Gr. F348H (2)	A312 Gr. TP347H	A376 Gr. TP348 (1)	A479 Gr. 348 (1)
A240 Gr. 347 (1)	A312 Gr. TP348 (1)	A376 Gr. TP348H (1)	A479 Gr. 348H
A240 Gr. 347H (2)	A312 Gr. TP348H	A430 Gr. FP347 (1)	

A — Standard Class							
Temperature, °F	Working Pressures by Class, psig						
	150	300	600	900	1500	2500	4500
-20 to 100	275	720	1,440	2,160	3,600	6,000	10,800
200	255	660	1,325	1,985	3,310	5,520	9,935
300	230	615	1,235	1,850	3,085	5,140	9,250
400	200	575	1,150	1,730	2,880	4,800	8,640
500	170	540	1,085	1,625	2,710	4,520	8,135
600	140	515	1,030	1,550	2,580	4,300	7,740
650	125	505	1,015	1,520	2,530	4,220	7,595
700	110	495	995	1,490	2,485	4,140	7,450
750	95	490	985	1,475	2,460	4,100	7,380
800	80	485	975	1,460	2,435	4,060	7,310
850	65	485	970	1,455	2,425	4,040	7,270
900	50	450	900	1,350	2,245	3,745	6,740
950	35	385	775	1,160	1,930	3,220	5,795
1,000	20	365	725	1,090	1,820	3,030	5,450
1,050	20 (3)	360	720	1,080	1,800	3,000	5,400
1,100	20 (3)	325	645	965	1,610	2,685	4,835
1,150	20 (3)	275	550	825	1,370	2,285	4,115
1,200	20 (3)	205	410	620	1,030	1,715	3,085
1,250	20 (3)	180	365	545	910	1,515	2,725
1,300	20 (3)	140	275	410	685	1,145	2,060
1,350	20 (3)	105	205	310	515	860	1,545
1,400	20 (3)	75	150	225	380	630	1,130
1,450	20 (3)	60	115	175	290	485	875
1,500	15 (3)	40	85	125	205	345	620

B — Special Class							
Temperature, °F	Working Pressure by Class, psig						
	150	300	600	900	1500	2500	4500
-20 to 100	290	750	1,500	2,250	3,750	6,250	11,250
200	285	740	1,480	2,220	3,695	6,160	11,090
300	265	690	1,375	2,065	3,440	5,735	10,325
400	245	645	1,285	1,930	3,215	5,355	9,645
500	230	605	1,210	1,815	3,025	5,045	9,080
600	220	575	1,150	1,730	2,880	4,800	8,640
650	215	565	1,130	1,695	2,825	4,710	8,480
700	215	555	1,110	1,665	2,770	4,620	8,315
750	210	550	1,100	1,645	2,745	4,575	8,235
800	210	545	1,090	1,630	2,720	4,530	8,155

**Table VII-2-2.5 Ratings for Group 2.5 Materials (Cont'd)**

<b>B — Special Class</b>							
<b>Temperature, °F</b>	<b>Working Pressure by Class, psig</b>						
	<b>150</b>	<b>300</b>	<b>600</b>	<b>900</b>	<b>1500</b>	<b>2500</b>	<b>4500</b>
850	205	540	1,080	1,625	2,705	4,510	8,115
900	205	540	1,080	1,625	2,705	4,510	8,115
950	180	470	945	1,415	2,360	3,930	7,070
1,000	160	420	840	1,260	2,105	3,505	6,310
1,050	160	420	840	1,260	2,105	3,505	6,310
1,100	155	405	805	1,210	2,015	3,360	6,045
1,150	130	345	685	1,030	1,715	2,860	5,145
1,200	100	260	515	770	1,285	2,145	3,860
1,250	90	230	455	680	1,135	1,895	3,410
1,300	65	170	345	515	860	1,430	2,570
1,350	50	130	260	385	645	1,070	1,930
1,400	35	95	190	285	470	785	1,415
1,450	30	75	145	220	365	610	1,095
1,500	20	50	105	155	260	430	770

## NOTES:

- (1) Not to be used over 1,000°F.
- (2) For temperatures over 1,000°F, use only if the material is heat treated by heating to a minimum temperature of 2,000°F.
- (3) Flanged-end valve ratings terminate at 1,000°F.

(17)

**Table VII-2-2.6 Ratings for Group 2.6 Materials**

A240 Gr. 309H	A312 Gr. TP309H	A358 Gr. 309H					
<b>A — Standard Class</b>							
Temperature, °F	Working Pressures by Class, psig						
	150	300	600	900	1500	2500	4500
-20 to 100	275	720	1,440	2,160	3,600	6,000	10,080
200	240	630	1,260	1,895	3,155	5,260	9,470
300	225	580	1,160	1,740	2,905	4,840	8,710
400	200	545	1,090	1,635	2,725	4,540	8,170
500	170	520	1,035	1,555	2,590	4,320	7,775
600	140	500	1,000	1,500	2,495	4,160	7,490
650	125	490	985	1,475	2,460	4,100	7,380
700	110	485	970	1,455	2,425	4,040	7,270
750	95	480	960	1,440	2,400	4,000	7,200
800	80	475	945	1,420	2,365	3,940	7,090
850	65	465	930	1,395	2,330	3,880	6,985
900	50	450	900	1,350	2,245	3,745	6,740
950	35	385	775	1,160	1,930	3,220	5,795
1,000	20	365	725	1,090	1,820	3,030	5,450
1,050	20 (1)	355	705	1,060	1,765	2,945	5,295
1,100	20 (1)	260	520	780	1,305	2,170	3,910
1,150	20 (1)	190	375	565	945	1,570	2,830
1,200	20 (1)	135	275	410	685	1,114	2,055
1,250	20 (1)	105	205	310	515	855	1,545
1,300	20 (1)	75	150	225	375	630	1,130
1,350	20 (1)	60	115	175	290	485	875
1,400	15 (1)	45	90	135	225	370	670
1,450	15 (1)	35	70	105	170	285	515
1,500	10 (1)	25	50	75	130	215	385
<b>B — Special Class</b>							
Temperature, °F	Working Pressure by Class, psig						
	150	300	600	900	1500	2500	4500
-20 to 100	290	750	1,500	2,250	3,750	6,250	11,250
200	270	705	1,410	2,115	3,520	5,870	10,565
300	250	650	1,295	1,945	3,240	5,400	9,725
400	235	610	1,215	1,825	3,040	5,065	9,120
500	220	580	1,155	1,735	2,895	4,820	8,680
600	215	555	1,115	1,670	2,785	4,645	8,355
650	210	550	1,100	1,645	2,745	4,575	8,235
700	205	540	1,080	1,625	2,705	4,510	8,115
750	205	535	1,070	1,605	2,680	4,465	8,035
800	200	530	1,055	1,585	2,640	4,395	7,915
850	200	520	1,040	1,560	2,600	4,330	7,795
900	195	510	1,025	1,535	2,560	4,265	7,675
950	180	470	945	1,415	2,360	3,930	7,070
1,000	160	420	840	1,260	2,105	3,505	6,310

(17)

**Table VII-2-2.6 Ratings for Group 2.6 Materials (Cont'd)**

<b>B — Special Class</b>							
<b>Temperature, °F</b>	<b>Working Pressure by Class, psig</b>						
	<b>150</b>	<b>300</b>	<b>600</b>	<b>900</b>	<b>1500</b>	<b>2500</b>	<b>4500</b>
1,050	160	420	840	1,260	2,105	3,505	6,310
1,100	125	325	650	975	1,630	2,715	4,885
1,150	90	235	470	705	1,180	1,965	3,535
1,200	65	170	345	515	855	1,430	2,570
1,250	50	130	255	385	645	1,070	1,930
1,300	35	95	190	285	470	785	1,415
1,350	30	75	145	220	365	605	1,095
1,400	20	55	110	165	280	465	835
1,450	15	45	85	130	215	355	645
1,500	10	30	65	95	160	270	480

NOTE: (1) Flanged-end valve ratings terminate at 1,000°F.

Table VII-2-2.7 Ratings for Group 2.7 Materials

A182 Gr. F310	A312 Gr. TP310H	A479 Gr. 310H					
A240 Gr. 310H	A358 Gr. 310H						
A — Standard Class							
Temperature, °F	Working Pressures by Class, psig						
	150	300	600	900	1500	2500	4500
-20 to 100	275	720	1,440	2,160	3,600	6,000	10,080
200	245	635	1,270	1,910	3,180	5,300	9,540
300	225	580	1,160	1,740	2,905	4,840	8,710
400	200	540	1,085	1,625	2,710	4,520	8,135
500	170	515	1,025	1,540	2,570	4,280	7,705
600	140	495	990	1,485	2,470	4,120	7,415
650	125	485	970	1,455	2,425	4,040	7,270
700	110	480	955	1,435	2,390	3,980	7,165
750	95	470	940	1,410	2,350	3,920	7,055
800	80	465	930	1,395	2,330	3,880	6,985
850	65	460	915	1,375	2,290	3,820	6,875
900	50	450	900	1,350	2,245	3,745	6,740
950	35	385	775	1,160	1,930	3,220	5,795
1,000	20	365	725	1,090	1,820	3,030	5,450
1,050	20 (1)	355	705	1,060	1,765	2,945	5,295
1,100	20 (1)	260	520	780	1,305	2,170	3,910
1,150	20 (1)	190	375	565	945	1,570	2,830
1,200	20 (1)	135	275	410	685	1,145	2,055
1,250	20 (1)	105	205	310	515	855	1,545
1,300	20 (1)	75	150	225	375	630	1,130
1,350	20 (1)	60	115	175	290	485	875
1,400	15 (1)	45	90	135	225	370	670
1,450	15 (1)	35	65	100	165	275	500
1,500	10 (1)	25	50	75	130	215	385
B — Special Class							
Temperature, °F	Working Pressure by Class, psig						
	150	300	600	900	1500	2500	4500
-20 to 100	290	750	1,500	2,250	3,750	6,250	11,250
200	270	710	1,420	2,130	3,550	5,915	10,645
300	250	650	1,295	1,945	3,240	5,400	9,725
400	230	605	1,210	1,815	3,025	5,045	9,080
500	220	575	1,145	1,720	2,865	4,775	8,600
600	210	550	1,105	1,655	2,760	4,600	8,275
650	205	540	1,080	1,625	2,705	4,510	8,115
700	205	535	1,065	1,600	2,665	4,440	7,995
750	200	525	1,050	1,575	2,625	4,375	7,875
800	200	520	1,040	1,560	2,600	4,330	7,795
850	195	510	1,025	1,535	2,560	4,265	7,675
900	195	505	1,005	1,510	2,520	4,195	7,555
950	180	470	945	1,415	2,360	3,930	7,070

**Table VII-2-2.7 Ratings for Group 2.7 Materials (Cont'd)**

<b>B — Special Class</b>							
<b>Temperature, °F</b>	<b>Working Pressure by Class, psig</b>						
	<b>150</b>	<b>300</b>	<b>600</b>	<b>900</b>	<b>1500</b>	<b>2500</b>	<b>4500</b>
1,000	160	420	840	1,260	2,105	3,505	6,310
1,050	160	420	840	1,260	2,105	3,505	6,310
1,100	125	325	650	975	1,630	2,715	4,885
1,150	90	235	470	705	1,180	1,965	3,535
1,200	65	170	345	515	855	1,430	2,570
1,250	50	130	255	385	645	1,070	1,930
1,300	35	95	190	285	470	785	1,415
1,350	30	75	145	220	365	605	1,095
1,400	20	55	110	165	280	465	835
1,450	15	40	85	125	210	345	625
1,500	10	30	65	95	160	270	480

NOTE: (1) Flanged-end valve ratings terminate at 1,000°F.

(17)

**Table VII-2-2.8 Ratings for Group 2.8 Materials**

A182 Gr. F44	A240 Gr. S32760 (1)	A479 Gr. S32750 (1)	A790 Gr. S32750 (1)
A182 Gr. F51 (1)	A312 Gr. S31254	A479 Gr. S32760 (1)	A790 Gr. S32760 (1)
A182 Gr. F53 (1)	A351 Gr. CK3MCuN	A789 Gr. S31803 (1)	A995 Gr. CD3MN (1)
A182 Gr. F55	A358 Gr. S31254	A789 Gr. S32750 (1)	A995 Gr. CD3MWCuN
A240 Gr. S31254	A479 Gr. S31254	A789 Gr. S32760 (1)	A995 Gr. CD4MCuN (1)
A240 Gr. S31803 (1)	A479 Gr. S31803 (1)	A790 Gr. S31803 (1)	A995 Gr. CE8MN (1)
A240 Gr. S32750 (1)			

**A — Standard Class**

Temperature, °F	Working Pressures by Class, psig						
	150	300	600	900	1500	2500	4500
-20 to 100	290	750	1,500	2,250	3,750	6,250	11,250
200	260	745	1,490	2,230	3,720	6,200	11,160
300	230	665	1,335	2,000	3,335	5,560	10,010
400	200	615	1,230	1,845	3,070	5,120	9,215
500	170	580	1,160	1,740	2,905	4,840	8,710
600	140	555	1,115	1,670	2,785	4,640	8,350
650	125	545	1,095	1,640	2,735	4,560	8,210
700	110	540	1,085	1,625	2,710	4,520	8,135
750	95	530	1,065	1,595	2,660	4,430	7,970

**B — Special Class**

Temperature, °F	Working Pressure by Class, psig						
	150	300	600	900	1500	2500	4500
-20 to 100	290	750	1,500	2,250	3,750	6,250	11,250
200	290	750	1,500	2,250	3,750	6,250	11,250
300	285	745	1,490	2,235	3,725	6,205	11,170
400	265	685	1,370	2,055	3,430	5,715	10,285
500	250	650	1,295	1,945	3,240	5,400	9,725
600	240	620	1,245	1,865	3,105	5,180	9,320
650	235	610	1,220	1,830	3,055	5,090	9,160
700	230	605	1,210	1,815	3,025	5,045	9,080
750	230	600	1,200	1,800	3,000	5,000	9,000

NOTE: (1) This steel may become brittle after service at moderately elevated temperatures. Not to be used over 600°F.



**Table VII-2-2.9 Ratings for Group 2.9 Materials**

A240 Gr. 309S (1)-(3)	A240 Gr. 310S (1)-(3)		A479 Gr. 310S (1)-(3)				
<b>A — Standard Class</b>							
Temperature, °F	Working Pressures by Class, psig						
	150	300	600	900	1500	2500	4500
-20 to 100	275	720	1,440	2,160	3,600	6,000	10,800
200	240	630	1,260	1,895	3,155	5,260	9,470
300	225	580	1,160	1,740	2,905	4,840	8,710
400	200	540	1,085	1,625	2,710	4,520	8,135
500	170	515	1,025	1,540	2,570	4,280	7,705
600	140	495	990	1,485	2,470	4,120	7,415
650	125	485	970	1,455	2,425	4,040	7,270
700	110	480	955	1,435	2,390	3,980	7,165
750	95	470	940	1,410	2,350	3,920	7,055
800	80	465	930	1,395	2,330	3,880	6,985
850	65	460	915	1,375	2,290	3,820	6,875
900	50	450	900	1,350	2,245	3,745	6,740
950	35	385	775	1,160	1,930	3,220	5,795
1,000	20	340	680	1,020	1,695	2,830	5,090
1,050	20 (4)	245	485	730	1,215	2,030	3,650
1,100	20 (4)	170	345	515	855	1,430	2,570
1,150	20 (4)	125	245	370	615	1,030	1,850
1,200	20 (4)	85	170	255	430	715	1,285
1,250	20 (4)	50	105	155	255	430	770
1,300	10 (4)	25	55	80	135	230	410
1,350	5 (4)	15	35	50	85	145	255
1,400	5 (4)	15	25	40	70	115	205
1,450	5 (4)	10	20	30	50	85	155
1,500	5 (4)	5	15	20	35	55	105
<b>B — Special Class</b>							
Temperature, °F	Working Pressure by Class, psig						
	150	300	600	900	1500	2500	4500
-20 to 100	290	750	1,500	2,250	3,750	6,250	11,250
200	270	705	1,410	2,115	3,520	5,870	10,565
300	250	650	1,295	1,945	3,240	5,400	9,725
400	230	605	1,210	1,815	3,025	5,045	9,080
500	220	575	1,145	1,720	2,865	4,775	8,600
600	210	550	1,105	1,655	2,760	4,600	8,275
650	205	540	1,080	1,625	2,705	4,510	8,115
700	205	535	1,065	1,600	2,665	4,440	7,995
750	200	525	1,050	1,575	2,625	4,375	7,875
800	200	520	1,040	1,560	2,600	4,330	7,795
850	195	510	1,025	1,535	2,560	4,265	7,675
900	195	505	1,005	1,510	2,520	4,195	7,555
950	180	470	945	1,415	2,360	3,930	7,070
1,000	160	420	840	1,260	2,105	3,505	6,310

**Table VII-2-2.9 Ratings for Group 2.9 Materials (Cont'd)**

<b>B — Special Class</b>							
<b>Temperature, °F</b>	<b>Working Pressure by Class, psig</b>						
	<b>150</b>	<b>300</b>	<b>600</b>	<b>900</b>	<b>1500</b>	<b>2500</b>	<b>4500</b>
1,050	115	305	610	915	1,520	2,535	4,565
1,100	80	215	430	645	1,070	1,785	3,215
1,150	60	155	310	465	770	1,285	2,315
1,200	40	105	215	320	535	895	1,605
1,250	25	65	130	195	320	535	965
1,300	15	35	70	105	170	285	515
1,350	10	20	45	65	105	180	320
1,400	5	15	35	50	85	145	255
1,450	5	15	25	40	65	105	195
1,500	5	10	15	25	45	70	130

## NOTES:

- (1) At temperatures above 1,000°F, use only when the carbon content is 0.04% or higher.
- (2) For temperatures above 1,000°F, use only if the material is solution heat treated to the minimum temperature specified in the material specification but not lower than 1,900°F and quenching in water or rapidly cooling by other means.
- (3) This material should be used for service temperatures 960°F and above only when assurance is provided that grain size is not finer than ASTM 6.
- (4) Flanged-end valve ratings terminate at 1,000°F.

**Table VII-2-2.10 Ratings for Group 2.10 Materials**

A351 Gr. CH8 (1)		A351 Gr. CH20 (1)					
A — Standard Class							
Temperature, °F	Working Pressures by Class, psig						
	150	300	600	900	1500	2500	4500
-20 to 100	260	670	1,345	2,015	3,360	5,600	10,080
200	210	550	1,100	1,650	2,750	4,580	8,245
300	195	505	1,015	1,520	2,530	4,220	7,595
400	185	485	970	1,455	2,425	4,040	7,270
500	170	470	940	1,410	2,350	3,920	7,055
600	140	455	910	1,370	2,280	3,800	6,840
650	125	445	895	1,340	2,230	3,720	6,695
700	110	435	870	1,305	2,170	3,620	6,515
750	95	420	845	1,265	2,110	3,520	6,335
800	80	410	820	1,230	2,050	3,420	6,155
850	65	400	795	1,195	1,990	3,320	5,975
900	50	385	770	1,150	1,920	3,200	5,760
950	35	370	740	1,110	1,850	3,080	5,545
1,000	20	340	675	1,015	1,690	2,820	5,075
1,050	20 (2)	290	585	875	1,455	2,430	4,370
1,100	20 (2)	225	445	670	1,115	1,855	3,345
1,150	20 (2)	170	345	515	855	1,430	2,570
1,200	20 (2)	130	260	390	650	1,085	1,955
1,250	20 (2)	100	200	300	495	830	1,490
1,300	20 (2)	80	160	235	395	655	1,185
1,350	20 (2)	60	125	185	310	515	925
1,400	15 (2)	45	90	135	225	370	670
1,450	10 (2)	30	60	95	155	255	465
1,500	10 (2)	25	55	80	135	230	410
B — Special Class							
Temperature, °F	Working Pressure by Class, psig						
	150	300	600	900	1500	2500	4500
-20 to 100	265	695	1,395	2,090	3,480	5,805	10,445
200	235	615	1,225	1,840	3,065	5,110	9,200
300	215	565	1,130	1,695	2,825	4,710	8,480
400	205	540	1,080	1,625	2,705	4,510	8,115
500	200	525	1,050	1,575	2,625	4,375	7,875
600	195	510	1,020	1,525	2,545	4,240	7,635
650	190	500	995	1,495	2,490	4,150	7,475
700	185	485	970	1,455	2,425	4,040	7,270
750	180	470	945	1,415	2,355	3,930	7,070
800	175	460	915	1,375	2,290	3,815	6,870
850	170	445	890	1,335	2,225	3,705	6,670
900	165	430	855	1,285	2,145	3,570	6,430
950	160	415	825	1,240	2,065	3,440	6,190
1,000	150	395	795	1,190	1,980	3,305	5,945

**Table VII-2-2.10 Ratings for Group 2.10 Materials (Cont'd)**

<b>B — Special Class</b>							
<b>Temperature, °F</b>	<b>Working Pressure by Class, psig</b>						
	<b>150</b>	<b>300</b>	<b>600</b>	<b>900</b>	<b>1500</b>	<b>2500</b>	<b>4500</b>
1,050	140	365	730	1,095	1,820	3,035	5,465
1,100	105	280	555	835	1,395	2,320	4,180
1,150	80	215	430	645	1,070	1,785	3,215
1,200	60	165	325	490	815	1,355	2,445
1,250	50	125	250	375	620	1,035	1,865
1,300	40	100	195	295	495	820	1,480
1,350	30	75	155	230	385	645	1,155
1,400	20	55	110	165	280	465	835
1,450	15	40	75	115	195	320	580
1,500	15	35	70	105	170	285	515

## NOTES:

- (1) At temperatures above 1,000°F, use only when the carbon content is 0.04% or higher.  
(2) Flanged-end valve ratings terminate at 1,000°F.

Table VII-2-2.11 Ratings for Group 2.11 Materials

A351 Gr. CF8C (1)							
A — Standard Class							
Temperature, °F	Working Pressures by Class, psig						
	150	300	600	900	1500	2500	4500
-20 to 100	275	720	1,440	2,160	3,600	6,000	10,800
200	255	660	1,325	1,985	3,310	5,520	9,935
300	230	615	1,235	1,850	3,085	5,140	9,250
400	200	575	1,150	1,730	2,880	4,800	8,640
500	170	540	1,085	1,625	2,710	4,520	8,135
600	140	515	1,030	1,550	2,580	4,300	7,740
650	125	505	1,015	1,520	2,530	4,220	7,595
700	110	495	995	1,490	2,485	4,140	7,450
750	95	490	985	1,475	2,460	4,100	7,380
800	80	485	975	1,460	2,435	4,060	7,310
850	65	485	970	1,455	2,425	4,040	7,270
900	50	450	900	1,350	2,245	3,745	6,740
950	35	385	775	1,160	1,930	3,220	5,795
1,000	20	365	725	1,090	1,820	3,030	5,450
1,050	20 (2)	360	720	1,080	1,800	3,000	5,400
1,100	20 (2)	310	625	935	1,560	2,600	4,680
1,150	20 (2)	210	420	625	1,045	1,745	3,135
1,200	20 (2)	150	300	455	755	1,255	2,265
1,250	20 (2)	115	225	340	565	945	1,695
1,300	20 (2)	75	150	225	375	630	1,130
1,350	20 (2)	50	105	155	255	430	770
1,400	15 (2)	40	80	125	205	345	615
1,450	10 (2)	30	60	95	155	255	465
1,500	10 (2)	25	55	80	135	230	410
B — Special Class							
Temperature, °F	Working Pressure by Class, psig						
	150	300	600	900	1500	2500	4500
-20 to 100	290	750	1,500	2,250	3,750	6,250	11,250
200	275	715	1,435	2,150	3,585	5,975	10,750
300	255	660	1,320	1,975	3,295	5,490	9,885
400	240	620	1,245	1,865	3,105	5,180	9,320
500	230	600	1,200	1,800	3,000	5,000	9,000
600	220	575	1,150	1,730	2,880	4,800	8,640
650	215	565	1,130	1,695	2,825	4,710	8,480
700	215	555	1,110	1,665	2,770	4,620	8,315
750	210	550	1,100	1,645	2,745	4,575	8,235
800	210	545	1,090	1,630	2,720	4,530	8,155
850	205	540	1,080	1,625	2,705	4,510	8,115
900	205	540	1,080	1,625	2,705	4,510	8,115
950	180	470	945	1,415	2,360	3,930	7,070
1,000	160	420	840	1,260	2,105	3,505	6,310

**Table VII-2-2.11 Ratings for Group 2.11 Materials (Cont'd)**

<b>B — Special Class</b>							
<b>Temperature, °F</b>	<b>Working Pressure by Class, psig</b>						
	<b>150</b>	<b>300</b>	<b>600</b>	<b>900</b>	<b>1500</b>	<b>2500</b>	<b>4500</b>
1,050	160	420	840	1,260	2,105	3,505	6,310
1,100	150	390	780	1,170	1,950	3,250	5,850
1,150	100	260	525	785	1,305	2,180	3,920
1,200	70	190	375	565	945	1,570	2,830
1,250	55	140	285	425	705	1,180	2,120
1,300	35	95	190	285	470	785	1,415
1,350	25	65	130	195	320	535	965
1,400	20	50	105	155	255	430	770
1,450	15	40	75	115	195	320	580
1,500	15	35	70	105	170	285	515

## NOTES:

- (1) At temperatures above 1,000°F, use only when the carbon content is 0.04% or higher.  
(2) Flanged-end valve ratings terminate at 1,000°F.

**Table VII-2-2.12 Ratings for Group 2.12 Materials**

A351 Gr. CK20 (1)							
A — Standard Class							
Temperature, °F	Working Pressures by Class, psig						
	150	300	600	900	1500	2500	4500
-20 to 100	260	670	1,345	2,015	3,360	5,600	10,080
200	210	550	1,100	1,650	2,750	4,580	8,245
300	195	505	1,015	1,520	2,530	4,220	7,595
400	185	485	970	1,455	2,425	4,040	7,270
500	170	470	940	1,410	2,350	3,920	7,055
600	140	455	910	1,370	2,280	3,800	6,840
650	125	445	895	1,340	2,230	3,720	6,695
700	110	435	870	1,305	2,170	3,620	6,515
750	95	420	845	1,265	2,110	3,520	6,335
800	80	410	820	1,230	2,050	3,420	6,155
850	65	400	795	1,195	1,990	3,320	5,975
900	50	385	770	1,150	1,920	3,200	5,760
950	35	370	740	1,110	1,850	3,080	5,545
1,000	20	340	675	1,015	1,690	2,820	5,075
1,050	20 (2)	325	650	975	1,630	2,715	4,885
1,100	20 (2)	290	585	875	1,455	2,430	4,370
1,150	20 (2)	250	500	750	1,250	2,085	3,755
1,200	20 (2)	205	410	615	1,030	1,715	3,085
1,250	20 (2)	165	330	495	825	1,370	2,470
1,300	20 (2)	120	240	360	600	1,000	1,800
1,350	20 (2)	80	165	245	410	685	1,235
1,400	20 (2)	55	110	165	275	455	825
1,450	15 (2)	40	75	115	190	315	565
1,500	10 (2)	25	55	80	135	230	410
B — Special Class							
Temperature, °F	Working Pressure by Class, psig						
	150	300	600	900	1500	2500	4500
-20 to 100	265	695	1,395	2,090	3,480	5,805	10,445
200	235	615	1,225	1,840	3,065	5,110	9,200
300	215	565	1,130	1,695	2,825	4,710	8,480
400	205	540	1,080	1,625	2,705	4,510	8,115
500	200	525	1,050	1,575	2,625	4,375	7,875
600	195	510	1,020	1,525	2,545	4,240	7,635
650	190	500	995	1,495	2,490	4,150	7,475
700	185	485	970	1,455	2,425	4,040	7,270
750	180	470	945	1,415	2,355	3,930	7,070
800	175	460	915	1,375	2,290	3,815	6,870
850	170	445	890	1,335	2,225	3,705	6,670
900	165	430	855	1,285	2,145	3,570	6,430
950	160	415	825	1,240	2,065	3,440	6,190
1,000	150	395	795	1,190	1,980	3,305	5,945

**Table VII-2-2.12 Ratings for Group 2.12 Materials (Cont'd)**

<b>B — Special Class</b>							
<b>Temperature, °F</b>	<b>Working Pressure by Class, psig</b>						
	<b>150</b>	<b>300</b>	<b>600</b>	<b>900</b>	<b>1500</b>	<b>2500</b>	<b>4500</b>
1,050	150	395	795	1,190	1,980	3,305	5,945
1,100	140	365	730	1,095	1,820	3,035	5,465
1,150	120	315	625	940	1,565	2,605	4,695
1,200	100	255	515	770	1,285	2,145	3,855
1,250	80	205	410	615	1,030	1,715	3,085
1,300	60	150	300	450	750	1,250	2,250
1,350	40	105	205	310	515	855	1,545
1,400	25	70	135	205	345	570	1,030
1,450	20	45	95	140	235	395	705
1,500	15	35	70	105	170	285	515

## NOTES:

- (1) At temperatures above 1,000°F, use only when the carbon content is 0.04% or higher.  
(2) Flanged-end valve ratings terminate at 1,000°F.



**Table VII-2-3.1 Ratings for Group 3.1 Materials**

B462 Gr. N08020 (1)	B463 Gr. N08020 (1)	B464 Gr. N08020 (1)	B468 Gr. N08020 (1)	B473 Gr. N08020 (1)			
<b>A — Standard Class</b>							
Temperature, °F	Working Pressures by Class, psig						
	150	300	600	900	1500	2500	4500
-20 to 100	290	750	1,500	2,250	3,750	6,250	11,250
200	260	740	1,485	2,225	3,710	6,180	11,125
300	230	710	1,420	2,130	3,550	5,920	10,655
400	200	680	1,365	2,045	3,410	5,680	10,225
500	170	655	1,310	1,965	3,275	5,460	9,830
600	140	605	1,210	1,815	3,025	5,040	9,070
650	125	590	1,175	1,765	2,940	4,905	8,825
700	110	570	1,135	1,705	2,840	4,730	8,515
750	95	530	1,065	1,595	2,660	4,430	7,970
800	80	510	1,015	1,525	2,540	4,230	7,610
<b>B — Special Class</b>							
Temperature, °F	Working Pressure by Class, psig						
	150	300	600	900	1500	2500	4500
-20 to 100	290	750	1,500	2,250	3,750	6,250	11,250
200	290	750	1,500	2,250	3,750	6,250	11,250
300	290	750	1,500	2,250	3,750	6,250	11,250
400	290	750	1,500	2,250	3,750	6,250	11,250
500	280	730	1,465	2,195	3,655	6,095	10,970
600	270	710	1,420	2,130	3,550	5,915	10,645
650	270	700	1,405	2,105	3,510	5,850	10,525
700	265	695	1,395	2,090	3,480	5,805	10,445
750	265	690	1,380	2,075	3,455	5,760	10,365
800	260	675	1,350	2,025	3,375	5,625	10,125

NOTE: (1) Use annealed material only.

**Table VII-2-3.2 Ratings for Group 3.2 Materials**

B160 Gr. N02200 (1)	B162 Gr. N02200 (1)	B163 Gr. N02200 (1)	B564 Gr. N02200 (1)				
B161 Gr. N02200 (1)							
<b>A — Standard Class</b>							
Temperature, °F	Working Pressures by Class, psig						
	150	300	600	900	1500	2500	4500
-20 to 100	185	480	960	1,440	2,400	4,000	7,200
200	185	480	960	1,440	2,400	4,000	7,200
300	185	480	960	1,440	2,400	4,000	7,200
400	185	480	960	1,440	2,400	4,000	7,200
500	170	455	905	1,360	2,270	3,780	6,805
600	140	415	825	1,240	2,065	3,440	6,190
<b>B — Special Class</b>							
Temperature, °F	Working Pressure by Class, psig						
	150	300	600	900	1500	2500	4500
100	205	535	1,070	1,605	2,680	4,465	8,035
200	205	535	1,070	1,605	2,680	4,465	8,035
300	205	535	1,070	1,605	2,680	4,465	8,035
400	205	535	1,070	1,605	2,680	4,465	8,035
500	195	505	1,015	1,520	2,530	4,220	7,595
600	175	460	920	1,380	2,305	3,840	6,910

NOTE: (1) Use annealed material only.

Table VII-2-3.3 Ratings for Group 3.3 Materials

B160 Gr. N02201 (1)		B162 Gr. N02201 (1)					
A — Standard Class							
Temperature, °F	Working Pressures by Class, psig						
	150	300	600	900	1500	2500	4500
-20 to 100	90	240	480	720	1,200	2,000	3,600
200	90	230	460	690	1,150	1,920	3,455
300	85	225	450	675	1,130	1,880	3,385
400	85	225	450	655	1,130	1,880	3,385
500	85	225	450	655	1,130	1,880	3,385
600	85	225	450	675	1,130	1,880	3,385
650	85	225	445	670	1,115	1,860	3,350
700	85	225	445	670	1,115	1,860	3,350
750	85	220	440	660	1,105	1,840	3,310
800	80	215	430	650	1,080	1,800	3,240
850	65	210	420	635	1,055	1,760	3,170
900	50	205	415	620	1,030	1,720	3,095
950	35	195	395	590	985	1,640	2,950
1,000	20	190	380	570	950	1,580	2,845
1,050	20 (2)	80	165	245	410	685	1,235
1,100	20 (2)	70	135	205	345	570	1,030
1,150	20 (2)	50	105	155	255	430	770
1,200	15 (2)	40	80	125	205	345	615
B — Special Class							
Temperature, °F	Working Pressure by Class, psig						
	150	300	600	900	1500	2500	4500
-20 to 100	105	270	535	805	1,340	2,230	4,020
200	100	255	515	770	1,285	2,145	3,855
300	95	250	505	755	1,260	2,100	3,775
400	95	250	505	755	1,260	2,100	3,775
500	95	250	505	755	1,260	2,100	3,775
600	95	250	505	755	1,260	2,100	3,775
650	95	250	500	745	1,245	2,075	3,735
700	95	250	500	745	1,245	2,075	3,735
750	95	245	495	740	1,130	2,055	3,695
800	90	240	480	725	1,205	2,010	3,615
850	90	235	470	705	1,180	1,965	3,535
900	90	230	460	690	1,150	1,920	3,455
950	85	220	440	660	1,100	1,830	3,295
1,000	80	210	425	635	1,060	1,765	3,175
1,050	40	105	205	310	515	855	1,545
1,100	35	85	170	255	430	715	1,285
1,150	25	65	130	195	320	535	965
1,200	20	50	105	155	255	430	770

## NOTES:

(1) Use annealed material only.

**Table VII-2-3.3 Ratings for Group 3.3 Materials (Cont'd)**

---

NOTES (Cont'd):

(2) Flanged-end ratings terminate at 1,000°F.

**Table VII-2-3.4 Ratings for Group 3.4 Materials**

B127 Gr. N04400 (1)	B164 Gr. N04400 (1)	B165 Gr. N04400 (1)	A494 Gr. M35-2 (1)
B163 Gr. N04400 (1)	B164 Gr. N04405 (1)	A494 Gr. M35-1 (1)	B564 Gr. N04400 (1)

**A — Standard Class**

Temperature, °F	Working Pressures by Class, psig						
	150	300	600	900	1500	2500	4500
-20 to 100	230	600	1,200	1,800	3,000	5,000	9,000
200	200	525	1,050	1,575	2,630	4,380	7,885
300	190	490	980	1,470	2,450	4,080	7,345
400	180	475	945	1,420	2,365	3,940	7,090
500	170	475	945	1,420	2,365	3,940	7,090
600	140	475	945	1,420	2,365	3,940	7,090
650	125	475	945	1,420	2,365	3,940	7,090
700	110	470	940	1,410	2,350	3,920	7,055
750	95	465	930	1,395	2,330	3,880	6,985
800	80	460	915	1,375	2,290	3,820	6,875
850	65	375	755	1,130	1,885	3,145	5,655
900	50	275	550	825	1,370	2,285	4,115

**B — Special Class**

Temperature, °F	Working Pressure by Class, psig						
	150	300	600	900	1500	2500	4500
-20 to 100	255	670	1,340	2,010	3,350	5,580	10,045
200	225	585	1,175	1,760	2,935	4,890	8,800
300	210	545	1,095	1,640	2,730	4,555	8,195
400	200	530	1,055	1,585	2,640	4,395	7,915
500	200	530	1,055	1,585	2,640	4,395	7,915
600	200	530	1,055	1,585	2,640	4,395	7,915
650	200	530	1,055	1,585	2,640	4,395	7,915
700	200	525	1,050	1,575	2,625	4,375	7,875
750	200	520	1,040	1,560	2,600	4,330	7,795
800	195	510	1,025	1,535	2,560	4,265	7,675
850	180	470	945	1,415	2,355	3,930	7,070
900	130	345	685	1,030	1,715	2,855	5,145

NOTE: (1) Use annealed material only.

Table VII-2-3.5 Ratings for Group 3.5 Materials

B163 Gr. N06600 (1)	B166 Gr. N06600 (1)	B168 Gr. N06600 (1)	B168 Gr. N06600 (1)	B168 Gr. N06600 (1)	B564 Gr. N06600 (1)	B564 Gr. N06600 (1)	
<b>A — Standard Class</b>							
Temperature, °F	Working Pressures by Class, psig						
	150	300	600	900	1500	2500	4500
-20 to 100	290	750	1,500	2,250	3,750	6,250	11,250
200	260	750	1,500	2,250	3,750	6,250	11,250
300	230	730	1,455	2,185	3,640	6,070	10,925
400	200	705	1,410	2,115	3,530	5,880	10,585
500	170	665	1,330	1,995	3,325	5,540	9,965
600	140	605	1,210	1,815	3,025	5,040	9,070
650	125	590	1,175	1,765	2,940	4,905	8,825
700	110	570	1,135	1,705	2,840	4,730	8,515
750	95	530	1,065	1,595	2,660	4,430	7,970
800	80	510	1,015	1,525	2,540	4,230	7,610
850	65	485	975	1,460	2,435	4,060	7,305
900	50	450	900	1,350	2,245	3,745	6,740
950	35	365	725	1,090	1,815	3,030	5,450
1,000	20	240	480	720	1,200	2,000	3,600
1,050	20 (2)	155	310	465	770	1,285	2,315
1,100	20 (2)	105	205	310	515	855	1,545
1,150	20 (2)	75	150	225	375	630	1,130
1,200	20 (2)	70	135	205	345	570	1,030
<b>B — Special Class</b>							
Temperature, °F	Working Pressure by Class, psig						
	150	300	600	900	1500	2500	4500
-20 to 100	290	750	1,500	2,250	3,750	6,250	11,250
200	290	750	1,500	2,250	3,750	6,250	11,250
300	290	750	1,500	2,250	3,750	6,250	11,250
400	290	750	1,500	2,250	3,750	6,250	11,250
500	290	750	1,500	2,250	3,750	6,250	11,250
600	290	750	1,500	2,250	3,750	6,250	11,250
650	290	750	1,500	2,250	3,750	6,250	11,250
700	280	735	1,465	2,200	3,665	6,110	10,995
750	280	730	1,460	2,185	3,645	6,070	10,930
800	275	720	1,440	2,160	3,600	6,000	10,800
850	260	680	1,355	2,030	3,385	5,645	10,160
900	230	600	1,200	1,800	3,000	5,000	9,000
950	175	455	910	1,365	2,270	3,785	6,815
1,000	115	300	600	900	1,500	2,500	4,500
1,050	75	195	385	580	965	1,605	2,895
1,100	50	130	255	385	645	1,070	1,930
1,150	35	95	190	285	470	785	1,415
1,200	35	85	170	255	430	715	1,285

## NOTES:

(1) Use annealed material only.

**Table VII-2-3.5 Ratings for Group 3.5 Materials (Cont'd)**

---

NOTES (Cont'd):

(2) Flanged-end valve ratings terminate at 1,000°F.

Table VII-2-3.6 Ratings for Group 3.6 Materials

B163 Gr. N08800 (1)	B408 Gr. N08800 (1)	B409 Gr. N08800 (1)	B564 Gr. N08800 (1)				
<b>A — Standard Class</b>							
Temperature, °F	Working Pressures by Class, psig						
	150	300	600	900	1500	2500	4500
-20 to 100	275	720	1,440	2,160	3,600	6,000	10,800
200	255	665	1,330	1,995	3,325	5,540	9,970
300	230	640	1,275	1,915	3,190	5,320	9,575
400	200	620	1,240	1,860	3,095	5,160	9,290
500	170	600	1,205	1,805	3,010	5,020	9,035
600	140	590	1,175	1,765	2,940	4,900	8,820
650	125	580	1,155	1,735	2,890	4,820	8,675
700	110	570	1,135	1,705	2,840	4,730	8,515
750	95	530	1,065	1,595	2,660	4,430	7,970
800	80	510	1,015	1,525	2,540	4,230	7,610
850	65	485	975	1,460	2,435	4,060	7,305
900	50	450	900	1,350	2,245	3,745	6,740
950	35	385	775	1,160	1,930	3,220	5,795
1,000	20	365	725	1,090	1,820	3,030	5,450
1,050	20 (2)	360	720	1,080	1,800	3,000	5,400
1,100	20 (2)	325	645	965	1,610	2,685	4,835
1,150	20 (2)	275	550	825	1,370	2,285	4,115
1,200	20 (2)	205	410	620	1,030	1,715	3,085
1,250	20 (2)	145	290	430	720	1,200	2,160
1,300	20 (2)	70	135	205	345	570	1,030
1,350	20 (2)	50	110	165	275	455	825
1,400	15 (2)	40	75	115	190	315	565
1,450	15 (2)	35	70	105	170	285	515
1,500	10 (2)	25	55	80	135	230	410
<b>B — Special Class</b>							
Temperature, °F	Working Pressure by Class, psig						
	150	300	600	900	1500	2500	4500
-20 to 100	290	750	1,500	2,250	3,750	6,250	11,250
200	285	740	1,485	2,225	3,710	6,185	11,130
300	275	715	1,425	2,140	3,565	5,940	10,690
400	265	690	1,380	2,075	3,455	5,760	10,365
500	260	670	1,345	2,015	3,360	5,605	10,085
600	250	655	1,315	1,970	3,280	5,470	9,845
650	245	645	1,290	1,935	3,230	5,380	9,685
700	245	640	1,275	1,915	3,190	5,315	9,565
750	240	630	1,260	1,890	3,145	5,245	9,440
800	240	620	1,245	1,865	3,105	5,180	9,320
850	235	615	1,225	1,840	3,065	5,110	9,200
900	230	600	1,200	1,800	3,000	5,000	9,000
950	180	470	945	1,415	2,360	3,930	7,070
1,000	160	420	840	1,260	2,105	3,505	6,310



**Table VII-2-3.6 Ratings for Group 3.6 Materials (Cont'd)**

<b>B — Special Class</b>							
<b>Temperature, °F</b>	<b>Working Pressure by Class, psig</b>						
	<b>150</b>	<b>300</b>	<b>600</b>	<b>900</b>	<b>1500</b>	<b>2500</b>	<b>4500</b>
1,050	160	420	840	1,260	2,105	3,505	6,310
1,100	155	405	805	1,210	2,015	3,360	6,045
1,150	130	345	685	1,030	1,715	2,860	5,145
1,200	100	260	515	770	1,285	2,145	3,860
1,250	70	180	360	540	900	1,500	2,700
1,300	35	85	170	255	430	715	1,285
1,350	25	70	135	205	345	570	1,030
1,400	20	45	95	140	235	395	705
1,450	15	45	85	130	215	355	645
1,500	15	35	70	105	170	285	515

## NOTES:

(1) Use annealed material only.

(2) Flanged-end valve ratings terminate at 1,000°F.

**Table VII-2-3.7 Ratings for Group 3.7 Materials**

B333 Gr. N10665 (1)	B335 Gr. N10675 (1)	B564 Gr. N10665 (1)	B622 Gr. N10675 (1)				
B333 Gr. N10675 (1)	B462 Gr. N10665 (1)	B564 Gr. N10675 (1)					
B335 Gr. N10665 (1)	B462 Gr. N10675 (1)	B622 Gr. N10665 (1)					
<b>A — Standard Class</b>							
Temperature, °F	Working Pressures by Class, psig						
	150	300	600	900	1500	2500	4500
-20 to 100	290	750	1,500	2,250	3,750	6,250	11,250
200	260	750	1,500	2,250	3,750	6,250	11,250
300	230	730	1,455	2,185	3,640	6,070	10,925
400	200	705	1,410	2,115	3,530	5,880	10,585
500	170	665	1,330	1,995	3,325	5,540	9,965
600	140	605	1,210	1,815	3,025	5,040	9,070
650	125	590	1,175	1,765	2,940	4,905	8,825
700	110	570	1,135	1,705	2,840	4,730	8,515
750	95	530	1,065	1,595	2,660	4,430	7,970
800	80	510	1,015	1,525	2,540	4,230	7,610
<b>B — Special Class</b>							
Temperature, °F	Working Pressure by Class, psig						
	150	300	600	900	1500	2500	4500
-20 to 100	290	750	1,500	2,250	3,750	6,250	11,250
200	290	750	1,500	2,250	3,750	6,250	11,250
300	290	750	1,500	2,250	3,750	6,250	11,250
400	290	750	1,500	2,250	3,750	6,250	11,250
500	290	750	1,500	2,250	3,750	6,250	11,250
600	290	750	1,500	2,250	3,750	6,250	11,250
650	290	750	1,500	2,250	3,750	6,250	11,250
700	280	735	1,465	2,200	3,665	6,110	10,995
750	280	730	1,460	2,185	3,645	6,070	10,930
800	275	720	1,440	2,160	3,600	6,000	10,800

NOTE: (1) Use solution annealed material only.

**Table VII-2-3.8 Ratings for Group 3.8 Materials**

B333 Gr. N10001 (1), (2)	B446 Gr. N06625 (3), (4)	B564 Gr. N10276 (1), (5)	B575 Gr. N06455 (1), (2)
B335 Gr. N10001 (1), (2)	B462 Gr. N06022 (1), (5)	B573 Gr. N10003 (3)	B575 Gr. N10276 (1), (5)
B423 Gr. N08825 (3), (6)	B462 Gr. N06200 (1), (2)	B574 Gr. N06022 (1), (5)	B622 Gr. N06022 (1), (5)
B424 Gr. N08825 (3), (6)	B462 Gr. N10276 (1), (5)	B574 Gr. N06200 (1), (2)	B622 Gr. N06200 (1), (2)
B425 Gr. N08825 (3), (6)	B564 Gr. N06022 (1), (5)	B574 Gr. N06455 (1), (2)	B622 Gr. N06455 (1), (2)
B434 Gr. N10003 (3)	B564 Gr. N06200 (1), (2)	B574 Gr. N10276 (1), (5)	B622 Gr. N10001 (2), (3)
B443 Gr. N06625 (3), (4)	B564 Gr. N06625 (3), (4)	B575 Gr. N06022 (1), (5)	B622 Gr. N10276 (1), (5)
	B564 Gr. N08825 (3), (6)	B575 Gr. N06200 (1), (2)	

**A — Standard Class**

Temperature, °F	Working Pressures by Class, psig						
	150	300	600	900	1500	2500	4500
-20 to 100	290	750	1,500	2,250	3,750	6,250	11,250
200	260	750	1,500	2,250	3,750	6,250	11,250
300	230	730	1,455	2,185	3,640	6,070	10,925
400	200	700	1,395	2,095	3,490	5,820	10,475
500	170	665	1,330	1,995	3,325	5,540	9,965
600	140	605	1,210	1,815	3,025	5,040	9,070
650	125	590	1,175	1,765	2,940	4,905	8,825
700	110	570	1,135	1,705	2,840	4,730	8,515
750	95	530	1,065	1,595	2,660	4,430	7,970
800	80	510	1,015	1,525	2,540	4,230	7,610
850	65	485	975	1,460	2,435	4,060	7,305
900	50	450	900	1,350	2,245	3,745	6,740
950	35	385	775	1,160	1,930	3,220	5,795
1,000	20	365	725	1,090	1,820	3,030	5,450
1,050	20 (7)	360	720	1,080	1,800	3,000	5,400
1,100	20 (7)	325	645	965	1,610	2,685	4,835
1,150	20 (7)	275	550	825	1,370	2,285	4,115
1,200	20 (7)	205	410	615	1,030	1,715	3,085
1,250	20 (7)	165	330	495	825	1,370	2,470
1,300	20 (7)	120	240	360	600	1,000	1,800

**B — Special Class**

Temperature, °F	Working Pressure by Class, psig						
	150	300	600	900	1500	2500	4500
-20 to 100	290	750	1,500	2,250	3,750	6,250	11,250
200	290	750	1,500	2,250	3,750	6,250	11,250
300	290	750	1,500	2,250	3,750	6,250	11,250
400	290	750	1,500	2,250	3,750	6,250	11,250
500	285	745	1,490	2,235	3,725	6,205	11,170
600	275	715	1,430	2,145	3,575	5,960	10,730
650	270	705	1,410	2,115	3,520	5,870	10,565
700	265	695	1,395	2,090	3,480	5,805	10,445
750	265	690	1,375	2,065	3,440	5,735	10,325
800	260	685	1,365	2,050	3,415	5,690	10,245
850	260	675	1,355	2,030	3,385	5,645	10,160
900	230	600	1,200	1,800	3,000	5,000	9,000

**Table VII-2-3.8 Ratings for Group 3.8 Materials (Cont'd)**

<b>B — Special Class</b>							
<b>Temperature, °F</b>	<b>Working Pressure by Class, psig</b>						
	<b>150</b>	<b>300</b>	<b>600</b>	<b>900</b>	<b>1500</b>	<b>2500</b>	<b>4500</b>
950	180	470	945	1,415	2,360	3,930	7,070
1,000	160	420	840	1,260	2,105	3,505	6,310
1,050	160	420	840	1,260	2,105	3,505	6,310
1,100	155	405	805	1,210	2,015	3,360	6,045
1,150	130	345	685	1,030	1,715	2,860	5,145
1,200	100	255	515	770	1,285	2,145	3,855
1,250	80	205	410	615	1,030	1,715	3,085
1,300	60	150	300	450	750	1,250	2,250

## NOTES:

- (1) Use solution annealed material only.
- (2) Not to be used over 800°F.
- (3) Use annealed material only.
- (4) Not to be used over 1,200°F. Alloy N06625 in the annealed condition is subject to severe loss of impact strength at room temperatures after exposure in the range of 1,000°F to 1,400°F.
- (5) Not to be used over 1,250°F.
- (6) Not to be used over 1,000°F.
- (7) Flanged-end valve ratings terminate at 1,000°F.

**Table VII-2-3.9 Ratings for Group 3.9 Materials**

B435 Gr. N06002 (1)		B572 Gr. N06002 (1)		B622 Gr. N06002 (1)		B622 Gr. R30556 (1)	
B435 Gr. R30556 (1)		B572 Gr. R30556 (1)					
<b>A — Standard Class</b>							
Temperature, °F	Working Pressures by Class, psig						
	150	300	600	900	1500	2500	4500
-20 to 100	290	750	1,500	2,250	3,750	6,250	11,250
200	260	750	1,500	2,250	3,750	6,250	11,250
300	230	690	1,380	2,075	3,455	5,760	10,370
400	200	640	1,275	1,915	3,190	5,320	9,575
500	170	595	1,190	1,785	2,975	4,960	8,930
600	140	565	1,130	1,690	2,820	4,700	8,460
650	125	550	1,105	1,655	2,760	4,600	8,280
700	110	540	1,085	1,625	2,710	4,520	8,135
750	95	530	1,065	1,595	2,660	4,430	7,970
800	80	510	1,015	1,525	2,540	4,230	7,610
850	65	485	975	1,460	2,435	4,060	7,305
900	50	450	900	1,350	2,245	3,745	6,740
950	35	385	775	1,160	1,930	3,220	5,795
1,000	20	365	725	1,090	1,820	3,030	5,450
1,050	20 (2)	360	720	1,080	1,800	3,000	5,400
1,100	20 (2)	325	645	965	1,610	2,685	4,835
1,150	20 (2)	275	550	825	1,370	2,285	4,115
1,200	20 (2)	205	410	620	1,030	1,715	3,085
1,250	20 (2)	180	365	545	910	1,515	2,725
1,300	20 (2)	140	275	410	685	1,145	2,060
1,350	20 (2)	105	205	310	515	860	1,545
1,400	20 (2)	75	150	225	380	630	1,130
1,450	20 (2)	60	115	175	290	485	875
1,500	15 (2)	40	85	125	205	345	620
<b>B — Special Class</b>							
Temperature, °F	Working Pressure by Class, psig						
	150	300	600	900	1500	2500	4500
-20 to 100	290	750	1,500	2,250	3,750	6,250	11,250
200	290	750	1,500	2,250	3,750	6,250	11,250
300	290	750	1,500	2,250	3,750	6,250	11,250
400	275	715	1,425	2,140	3,565	5,940	10,690
500	255	665	1,330	1,995	3,320	5,535	9,965
600	240	630	1,260	1,890	3,145	5,245	9,440
650	235	615	1,230	1,850	3,080	5,135	9,240
700	230	605	1,210	1,815	3,025	5,045	9,080
750	230	595	1,195	1,790	2,985	4,980	8,960
800	225	590	1,185	1,775	2,960	4,935	8,880
850	225	585	1,175	1,760	2,935	4,890	8,800
900	225	580	1,165	1,745	2,905	4,845	8,720
950	180	470	945	1,415	2,360	3,930	7,070

**Table VII-2-3.9 Ratings for Group 3.9 Materials (Cont'd)**

<b>B — Special Class</b>							
<b>Temperature, °F</b>	<b>Working Pressure by Class, psig</b>						
	<b>150</b>	<b>300</b>	<b>600</b>	<b>900</b>	<b>1500</b>	<b>2500</b>	<b>4500</b>
1,000	160	420	840	1,260	2,105	3,505	6,310
1,050	160	420	840	1,260	2,105	3,505	6,310
1,100	155	405	805	1,210	2,015	3,360	6,045
1,150	130	345	685	1,030	1,715	2,860	5,145
1,200	100	260	515	770	1,285	2,145	3,860
1,250	90	230	455	680	1,135	1,895	3,410
1,300	65	170	345	515	860	1,430	2,570
1,350	50	130	260	385	645	1,070	1,930
1,400	35	95	190	285	470	785	1,415
1,450	30	75	145	220	365	610	1,095
1,500	20	50	105	155	260	430	770

## NOTES:

(1) Use solution annealed material only.

(2) For welding-end valves only. Flanged-end valve ratings terminate at 1,000°F.

**Table VII-2-3.10 Ratings for Group 3.10 Materials**

<b>B599 Gr. N08700 (1)</b>								<b>B672 Gr. N08700 (1)</b>							
<b>A — Standard Class</b>															
<b>Temperature, °F</b>	<b>Working Pressures by Class, psig</b>														
	<b>150</b>	<b>300</b>	<b>600</b>	<b>900</b>	<b>1500</b>	<b>2500</b>	<b>4500</b>	<b>150</b>	<b>300</b>	<b>600</b>	<b>900</b>	<b>1500</b>	<b>2500</b>	<b>4500</b>	
-20 to 100	290	750	1,500	2,250	3,750	6,250	11,250	290	750	1,500	2,250	3,750	6,250	11,250	
200	260	750	1,500	2,250	3,750	6,250	11,250	260	750	1,500	2,250	3,750	6,250	11,250	
300	230	685	1,370	2,050	3,420	5,700	10,260	230	685	1,370	2,050	3,420	5,700	10,260	
400	200	640	1,275	1,915	3,190	5,320	9,575	200	640	1,275	1,915	3,190	5,320	9,575	
500	170	615	1,235	1,850	3,085	5,140	9,250	170	615	1,235	1,850	3,085	5,140	9,250	
600	140	595	1,185	1,780	2,965	4,940	8,990	140	595	1,185	1,780	2,965	4,940	8,990	
650	125	570	1,140	1,715	2,855	4,760	8,570	125	570	1,140	1,715	2,855	4,760	8,570	
<b>B — Special Class</b>															
<b>Temperature, °F</b>	<b>Working Pressure by Class, psig</b>														
	<b>150</b>	<b>300</b>	<b>600</b>	<b>900</b>	<b>1500</b>	<b>2500</b>	<b>4500</b>	<b>150</b>	<b>300</b>	<b>600</b>	<b>900</b>	<b>1500</b>	<b>2500</b>	<b>4500</b>	
-20 to 100	290	750	1,500	2,250	3,750	6,250	11,250	290	750	1,500	2,250	3,750	6,250	11,250	
200	290	750	1,500	2,250	3,750	6,250	11,250	290	750	1,500	2,250	3,750	6,250	11,250	
300	290	750	1,500	2,250	3,750	6,250	11,250	290	750	1,500	2,250	3,750	6,250	11,250	
400	275	715	1,425	2,140	3,565	5,940	10,690	275	715	1,425	2,140	3,565	5,940	10,690	
500	265	690	1,375	2,065	3,440	5,735	10,325	265	690	1,375	2,065	3,440	5,735	10,325	
600	255	660	1,325	1,985	3,310	5,515	9,925	255	660	1,325	1,985	3,310	5,515	9,925	
650	245	640	1,275	1,915	3,190	5,315	9,565	245	640	1,275	1,915	3,190	5,315	9,565	

NOTE: (1) Use solution annealed material only.

**Table VII-2-3.11 Ratings for Group 3.11 Materials**

B625 Gr. N08904 (1)		B649 Gr. N08904 (1)			B677 Gr. N08904 (1)		
<b>A — Standard Class</b>							
Temperature, °F	Working Pressures by Class, psig						
	150	300	600	900	1500	2500	4500
-20 to 100	285	745	1,490	2,230	3,720	6,200	11,160
200	230	600	1,205	1,805	3,010	5,020	9,035
300	210	545	1,090	1,635	2,725	4,540	8,170
400	190	500	1,000	1,500	2,495	4,160	7,490
500	170	455	910	1,370	2,280	3,800	6,840
600	140	425	855	1,280	2,135	3,560	6,410
650	125	420	835	1,255	2,090	3,480	6,265
700	110	410	820	1,230	2,050	3,420	6,155
<b>B — Special Class</b>							
Temperature, °F	Working Pressure by Class, psig						
	150	300	600	900	1500	2500	4500
-20 to 100	290	750	1,500	2,250	3,750	6,250	11,250
200	260	670	1,345	2,015	3,360	5,605	10,085
300	235	610	1,215	1,825	3,040	5,065	9,120
400	215	555	1,115	1,670	2,785	4,645	8,355
500	195	510	1,020	1,525	2,545	4,240	7,635
600	185	475	955	1,430	2,385	3,975	7,150
650	180	465	930	1,400	2,330	3,885	6,990
700	175	460	915	1,375	2,290	3,815	6,870

NOTE: (1) Use annealed material only.

**Table VII-2-3.12 Ratings for Group 3.12 Materials**

A351 Gr. CN3MN (1)	B574 Gr. N06035 (1), (2)	B620 Gr. N08320 (1)	B622 Gr. N08320 (1)				
B462 Gr. N06035 (1), (2)	B575 Gr. N06035 (1), (2)	B621 Gr. N08320 (1)	B688 Gr. N08367 (1)				
B462 Gr. N08367 (1)	B581 Gr. N06985 (1)	B622 Gr. N06035 (1), (2)	B691 Gr. N08367 (1), (2)				
B564 Gr. N06035 (1), (2)	B582 Gr. N06985 (1)	B622 Gr. N06985 (1)					
<b>A — Standard Class</b>							
<b>Temperature, °F</b>	<b>Working Pressures by Class, psig</b>						
	<b>150</b>	<b>300</b>	<b>600</b>	<b>900</b>	<b>1500</b>	<b>2500</b>	<b>4500</b>
-20 to 100	260	670	1,345	2,015	3,360	5,600	10,080
200	240	620	1,245	1,865	3,110	5,180	9,325
300	225	585	1,165	1,750	2,915	4,860	8,750
400	200	540	1,075	1,615	2,690	4,480	8,065
500	170	500	1,000	1,500	2,495	4,160	7,490
600	140	475	945	1,420	2,365	3,940	7,090
650	125	460	920	1,380	2,305	3,840	6,910
700	110	450	900	1,355	2,255	3,760	6,770
750	95	440	885	1,325	2,210	3,680	6,625
800	80	430	865	1,295	2,160	3,600	6,480
<b>B — Special Class</b>							
<b>Temperature, °F</b>	<b>Working Pressure by Class, psig</b>						
	<b>150</b>	<b>300</b>	<b>600</b>	<b>900</b>	<b>1500</b>	<b>2500</b>	<b>4500</b>
-20 to 100	290	750	1,500	2,250	3,750	6,250	11,250
200	265	695	1,390	2,080	3,470	5,780	10,405
300	250	650	1,300	1,955	3,255	5,425	9,765
400	230	600	1,200	1,800	3,000	5,000	9,000
500	215	555	1,115	1,670	2,785	4,645	8,355
600	200	530	1,055	1,585	2,640	4,395	7,915
650	195	515	1,030	1,545	2,570	4,285	7,715
700	195	505	1,005	1,510	2,520	4,195	7,555
750	190	495	985	1,480	2,465	4,105	7,395
800	185	480	965	1,445	2,410	4,020	7,230

## NOTES:

- (1) Use solution annealed material only.  
(2) Not to be used over 800°F.



**Table VII-2-3.13 Ratings for Group 3.13 Materials**

B564 Gr. N08031 (1)	B582 Gr. N06975 (2)	B622 Gr. N08031 (1)	B649 Gr. N08031 (1)
B581 Gr. N06975 (2)	B622 Gr. N06975 (2)	B625 Gr. N08031 (1)	

**A — Standard Class**

Temperature, °F	Working Pressures by Class, psig						
	150	300	600	900	1500	2500	4500
-20 to 100	290	750	1,500	2,250	3,750	6,250	11,250
200	260	705	1,405	2,110	3,515	5,860	10,550
300	230	665	1,330	1,995	3,325	5,540	9,970
400	200	630	1,260	1,885	3,145	5,240	9,430
500	170	595	1,190	1,785	2,975	4,960	8,930
600	140	560	1,125	1,685	2,810	4,680	8,425
650	125	550	1,100	1,650	2,750	4,580	8,245
700	110	540	1,080	1,620	2,700	4,500	8,100
750	95	530	1,065	1,595	2,660	4,430	7,970
800	80	510	1,015	1,525	2,540	4,230	7,610

**B — Special Class**

Temperature, °F	Working Pressure by Class, psig						
	150	300	600	900	1500	2500	4500
-20 to 100	290	750	1,500	2,250	3,750	6,250	11,250
200	290	750	1,500	2,250	3,750	6,250	11,250
300	285	740	1,485	2,225	3,710	6,185	11,130
400	270	700	1,405	2,105	3,510	5,850	10,525
500	255	665	1,330	1,995	3,320	5,535	9,965
600	240	625	1,255	1,880	3,135	5,225	9,400
650	235	615	1,225	1,840	3,065	5,110	9,200
700	230	605	1,205	1,810	3,015	5,020	9,040
750	230	595	1,190	1,785	2,975	4,955	8,920
800	225	590	1,180	1,770	2,945	4,910	8,840

NOTES:

(1) Use annealed material only.

(2) Use solution annealed material only.

Table VII-2-3.14 Ratings for Group 3.14 Materials

B462 Gr. N06030 (1), (2)		B581 Gr. N06030 (1), (2)		B582 Gr. N06030 (1), (2)		B622 Gr. N06030 (1), (2)	
B581 Gr. N06007 (1)		B582 Gr. N06007 (1)		B622 Gr. N06007 (1)			
A — Standard Class							
Temperature, °F	Working Pressures by Class, psig						
	150	300	600	900	1500	2500	4500
-20 to 100	275	720	1,440	2,160	3,600	6,000	10,800
200	250	650	1,295	1,945	3,240	5,400	9,720
300	230	600	1,200	1,800	3,000	5,000	9,000
400	200	565	1,130	1,690	2,820	4,700	8,460
500	170	540	1,075	1,615	2,690	4,480	8,065
600	140	520	1,035	1,555	2,590	4,320	7,775
650	125	510	1,020	1,535	2,555	4,260	7,670
700	110	505	1,015	1,520	2,530	4,220	7,595
750	95	500	1,005	1,505	2,510	4,180	7,525
800	80	500	1,000	1,500	2,495	4,160	7,490
850	65	485	975	1,460	2,435	4,060	7,305
900	50	450	900	1,350	2,245	3,745	6,740
950	35	385	775	1,160	1,930	3,220	5,795
1,000	20	365	725	1,090	1,820	3,030	5,450
B — Special Class							
Temperature, °F	Working Pressure by Class, psig						
	150	300	600	900	1500	2500	4500
-20 to 100	290	750	1,500	2,250	3,750	6,250	11,250
200	275	725	1,445	2,170	3,615	6,025	10,850
300	255	670	1,340	2,010	3,350	5,580	10,045
400	240	630	1,260	1,890	3,145	5,245	9,440
500	230	600	1,200	1,800	3,000	5,000	9,000
600	220	580	1,155	1,735	2,895	4,820	8,680
650	220	570	1,140	1,710	2,855	4,755	8,560
700	215	565	1,130	1,695	2,825	4,710	8,480
750	215	560	1,120	1,680	2,800	4,665	8,395
800	215	555	1,115	1,670	2,785	4,645	8,355
850	215	555	1,110	1,665	2,770	4,620	8,315
900	210	550	1,105	1,655	2,760	4,600	8,275
950	180	470	945	1,415	2,360	3,930	7,070
1,000	160	420	840	1,260	2,105	3,505	6,310

## NOTES:

- (1) Use solution annealed material only.  
(2) Not to be used over 800°F.

**Table VII-2-3.15 Ratings for Group 3.15 Materials**

A494 Gr. CW-12MW (1), (2)	B407 Gr. N08810 (1)	B409 Gr. N08810 (1)	B564 Gr. N08810 (1)
A494 Gr. N-12MV (1), (2)	B408 Gr. N08810 (1)		

**A — Standard Class**

Temperature, °F	Working Pressures by Class, psig						
	150	300	600	900	1500	2500	4500
-20 to 100	230	600	1,200	1,800	3,000	5,000	9,000
200	210	550	1,105	1,655	2,760	4,600	8,280
300	200	520	1,040	1,560	2,605	4,340	7,810
400	190	490	980	1,470	2,450	4,080	7,345
500	170	465	925	1,390	2,315	3,860	6,950
600	140	440	880	1,320	2,195	3,660	6,590
650	125	430	860	1,290	2,150	3,580	6,445
700	110	420	835	1,255	2,090	3,480	6,265
750	95	410	820	1,230	2,050	3,420	6,155
800	80	400	800	1,200	2,005	3,340	6,010
850	65	395	785	1,180	1,970	3,280	5,905
900	50	385	775	1,160	1,930	3,220	5,795
950	35	380	760	1,140	1,895	3,160	5,690
1,000	20	365	725	1,090	1,820	3,030	5,450
1,050	20 (3)	350	700	1,050	1,750	2,915	5,245
1,100	20 (3)	325	645	965	1,610	2,685	4,835
1,150	20 (3)	275	550	825	1,370	2,285	4,115
1,200	20 (3)	205	410	620	1,030	1,715	3,085
1,250	20 (3)	180	365	545	910	1,515	2,725
1,300	20 (3)	140	275	410	685	1,145	2,060
1,350	20 (3)	105	205	310	515	860	1,545
1,400	20 (3)	75	150	225	380	630	1,130
1,450	20 (3)	60	115	175	290	485	875
1,500	15 (3)	40	85	125	205	345	620

**B — Special Class**

Temperature, °F	Working Pressure by Class, psig						
	150	300	600	900	1500	2500	4500
-20 to 100	255	670	1,340	2,010	3,350	5,580	10,045
200	235	615	1,230	1,850	3,080	5,135	9,040
300	225	580	1,165	1,745	2,905	4,845	8,720
400	210	545	1,095	1,640	2,730	4,555	8,195
500	200	515	1,035	1,550	2,585	4,310	7,755
600	190	490	980	1,470	2,450	4,085	7,355
650	185	480	960	1,440	2,395	3,995	7,190
700	180	465	930	1,400	2,330	3,885	6,990
750	175	460	915	1,375	2,290	3,815	6,870
800	170	445	895	1,340	2,235	3,730	6,710
850	170	440	880	1,320	2,195	3,660	6,590
900	165	430	865	1,295	2,155	3,595	6,470
950	160	425	845	1,270	2,115	3,525	6,350

**Table VII-2-3.15 Ratings for Group 3.15 Materials (Cont'd)**

<b>B — Special Class</b>							
<b>Temperature, °F</b>	<b>Working Pressure by Class, psig</b>						
	<b>150</b>	<b>300</b>	<b>600</b>	<b>900</b>	<b>1500</b>	<b>2500</b>	<b>4500</b>
1,000	160	415	830	1,245	2,075	3,460	6,230
1,050	160	415	830	1,245	2,075	3,460	6,230
1,100	155	405	805	1,210	2,015	3,360	6,045
1,150	130	345	685	1,030	1,715	2,860	5,145
1,200	100	260	515	770	1,285	2,145	3,860
1,250	90	230	455	680	1,135	1,895	3,410
1,300	65	170	345	515	860	1,430	2,570
1,350	50	130	260	385	645	1,070	1,930
1,400	35	95	190	285	470	785	1,415
1,450	30	75	145	220	365	610	1,095
1,500	20	50	105	155	260	430	770

## NOTES:

- (1) Use solution annealed material only.
- (2) Not to be used over 1,000°F.
- (3) Flanged-end valve ratings terminate at 1,000°F.

**Table VII-2-3.16 Ratings for Group 3.16 Materials**

B511 Gr. N08330 (1)	B535 Gr. N08330 (1)		B536 Gr. N08330 (1)				
<b>A — Standard Class</b>							
Temperature, °F	Working Pressures by Class, psig						
	150	300	600	900	1500	2500	4500
-20 to 100	275	720	1,440	2,160	3,600	6,000	10,800
200	245	635	1,270	1,910	3,180	5,300	9,540
300	225	595	1,185	1,780	2,965	4,940	8,890
400	200	555	1,115	1,670	2,785	4,640	8,350
500	170	530	1,055	1,585	2,640	4,400	7,920
600	140	505	1,010	1,510	2,520	4,200	7,560
650	125	495	990	1,485	2,470	4,120	7,415
700	110	480	965	1,445	2,410	4,020	7,235
750	95	475	945	1,420	2,365	3,940	7,090
800	80	465	925	1,390	2,315	3,860	6,950
850	65	455	905	1,360	2,270	3,780	6,805
900	50	445	890	1,330	2,220	3,700	6,660
950	35	385	775	1,160	1,930	3,220	5,795
1,000	20	365	725	1,090	1,820	3,030	5,450
1,050	20 (2)	345	685	1,030	1,715	2,855	5,145
1,100	20 (2)	265	535	800	1,335	2,230	4,010
1,150	20 (2)	205	410	615	1,030	1,715	3,085
1,200	20 (2)	160	320	485	805	1,345	2,415
1,250	20 (2)	130	260	390	650	1,085	1,955
1,300	20 (2)	105	215	320	530	885	1,595
1,350	20 (2)	80	165	245	410	685	1,235
1,400	20 (2)	60	125	185	310	515	925
1,450	20 (2)	50	105	155	255	430	770
1,500	15 (2)	40	75	115	190	315	565
<b>B — Special Class</b>							
Temperature, °F	Working Pressure by Class, psig						
	150	300	600	900	1500	2500	4500
-20 to 100	290	750	1,500	2,250	3,750	6,250	11,250
200	270	710	1,420	2,130	3,550	5,915	10,645
300	255	660	1,325	1,985	3,310	5,515	9,925
400	240	620	1,245	1,865	3,105	5,180	9,320
500	225	590	1,180	1,770	2,945	4,910	8,840
600	215	565	1,125	1,690	2,815	4,690	8,440
650	210	550	1,105	1,655	2,760	4,600	8,275
700	205	540	1,075	1,615	2,690	4,485	8,075
750	200	530	1,055	1,585	2,640	4,395	7,915
800	200	515	1,035	1,550	2,585	4,310	7,755
850	195	505	1,015	1,520	2,530	4,220	7,595
900	190	495	990	1,485	2,480	4,130	7,435
950	180	470	945	1,415	2,360	3,930	7,070
1,000	160	420	840	1,260	2,105	3,505	6,310

**Table VII-2-3.16 Ratings for Group 3.16 Materials (Cont'd)**

<b>B — Special Class</b>							
<b>Temperature, °F</b>	<b>Working Pressure by Class, psig</b>						
	<b>150</b>	<b>300</b>	<b>600</b>	<b>900</b>	<b>1500</b>	<b>2500</b>	<b>4500</b>
1,050	160	420	840	1,260	2,015	3,305	6,310
1,100	130	335	670	1,005	1,670	2,785	5,015
1,150	100	255	515	770	1,285	2,145	3,855
1,200	75	120	405	605	1,005	1,680	3,020
1,250	60	165	325	490	815	1,355	2,445
1,300	50	135	265	400	665	1,105	1,995
1,350	40	105	205	310	515	855	1,545
1,400	30	75	155	230	385	645	1,155
1,450	25	65	130	195	320	535	965
1,500	20	45	95	140	235	395	705

## NOTES:

(1) Use solution annealed material only.

(2) Flanged-end valve ratings terminate at 1,000°F.

**Table VII-2-3.17 Ratings for Group 3.17 Materials**

A351 Gr. CN7M (1)

<b>A — Standard Class</b>							
<b>Temperature, °F</b>	<b>Working Pressures by Class, psig</b>						
	<b>150</b>	<b>300</b>	<b>600</b>	<b>900</b>	<b>1500</b>	<b>2500</b>	<b>4500</b>
-20 to 100	230	600	1,200	1,800	3,000	5,000	9,000
200	200	520	1,035	1,555	2,590	4,320	7,775
300	180	465	930	1,395	2,330	3,880	6,985
400	160	420	845	1,265	2,110	3,520	6,335
500	150	390	780	1,165	1,945	3,240	5,830
600	140	360	720	1,080	1,800	3,000	5,400

<b>B — Special Class</b>							
<b>Temperature, °F</b>	<b>Working Pressure by Class, psig</b>						
	<b>150</b>	<b>300</b>	<b>600</b>	<b>900</b>	<b>1500</b>	<b>2500</b>	<b>4500</b>
-20 to 100	255	665	1,330	1,995	3,320	5,535	9,965
200	215	560	1,125	1,685	2,805	4,680	8,420
300	195	510	1,020	1,535	2,550	4,260	7,665
400	180	470	945	1,415	2,355	3,930	7,070
500	165	435	870	1,300	2,170	3,615	6,510
600	155	400	805	1,205	2,010	3,350	6,025

NOTE: (1) Use solution annealed material only.

Table VII-2-3.18 Ratings for Group 3.18 Materials

B167 Gr. N06600 (1)							
A — Standard Class							
Temperature, °F	Working Pressures by Class, psig						
	150	300	600	900	1500	2500	4500
-20 to 100	275	720	1,440	2,160	3,600	6,000	10,800
200	260	685	1,375	2,060	3,430	5,720	10,295
300	230	660	1,315	1,975	3,290	5,480	9,865
400	200	630	1,260	1,885	3,145	5,240	9,430
500	170	605	1,210	1,815	3,025	5,040	9,070
600	140	585	1,165	1,750	2,915	4,860	8,750
650	125	575	1,145	1,720	2,870	4,780	8,605
700	110	565	1,130	1,690	2,820	4,700	8,460
750	95	530	1,065	1,595	2,660	4,430	7,970
800	80	510	1,015	1,525	2,540	4,230	7,610
850	65	485	975	1,460	2,435	4,060	7,305
900	50	450	900	1,350	2,245	3,745	6,740
950	35	365	725	1,090	1,815	3,030	5,450
1,000	20	240	480	720	1,200	2,000	3,600
1,050	20 (2)	155	310	465	770	1,285	2,315
1,100	20 (2)	105	205	310	515	855	1,545
1,150	20 (2)	75	150	225	375	630	1,130
1,200	20 (2)	70	135	205	345	570	1,030
B — Special Class							
Temperature, °F	Working Pressure by Class, psig						
	150	300	600	900	1500	2500	4500
-20 to 100	290	750	1,500	2,250	3,750	6,250	11,250
200	290	750	1,500	2,250	3,750	6,250	11,250
300	280	735	1,470	2,200	3,670	6,115	11,010
400	270	700	1,405	2,105	3,510	5,850	10,525
500	260	675	1,350	2,025	3,375	5,625	10,125
600	250	650	1,300	1,955	3,255	5,425	9,765
650	245	640	1,280	1,920	3,200	5,335	9,605
700	240	630	1,260	1,890	3,145	5,245	9,440
750	240	620	1,245	1,865	3,105	5,180	9,320
800	235	615	1,225	1,840	3,065	5,110	9,200
850	230	605	1,210	1,815	3,025	5,045	9,080
900	230	595	1,195	1,790	2,985	4,980	8,960
950	175	455	910	1,365	2,270	3,785	6,815
1,000	115	300	600	900	1,500	2,500	4,500
1,050	75	195	385	580	965	1,605	2,895
1,100	50	130	255	385	645	1,070	1,930
1,150	35	95	190	285	470	785	1,415
1,200	35	85	170	255	430	715	1,285

## NOTES:

(1) Only use annealed material.

**Table VII-2-3.18 Ratings for Group 3.18 Materials (Cont'd)**

---

NOTES (Cont'd):

(2) Flanged-end valve ratings terminate at 1,000°F.



**Table VII-2-3.19 Ratings for Group 3.19 Materials**

B435 Gr. N06230 (1)	B564 Gr. N06230 (1)		B572 Gr. N06230 (1)		B622 Gr. N06230 (1)		
<b>A — Standard Class</b>							
Temperature, °F	Working Pressures by Class, psig						
	150	300	600	900	1500	2500	4500
-20 to 100	290	750	1,500	2,250	3,750	6,250	11,250
200	260	750	1,500	2,250	3,750	6,250	11,250
300	230	730	1,455	2,185	3,640	6,070	10,925
400	200	705	1,410	2,115	3,530	5,880	10,585
500	170	665	1,330	1,995	3,325	5,540	9,965
600	140	605	1,210	1,815	3,025	5,040	9,070
650	125	590	1,175	1,765	2,940	4,905	8,825
700	110	570	1,135	1,705	2,840	4,730	8,515
750	95	530	1,065	1,595	2,660	4,430	7,970
800	80	510	1,015	1,525	2,540	4,230	7,610
850	65	485	975	1,460	2,435	4,060	7,305
900	50	450	900	1,350	2,245	3,745	6,740
950	35	385	775	1,160	1,930	3,220	5,795
1,000	20	365	725	1,090	1,820	3,030	5,450
1,050	20 (2)	360	720	1,080	1,800	3,000	5,400
1,100	20 (2)	325	645	965	1,610	2,685	4,835
1,150	20 (2)	275	550	825	1,370	2,285	4,115
1,200	20 (2)	205	410	620	1,030	1,715	3,085
1,250	20 (2)	180	365	545	910	1,515	2,725
1,300	20 (2)	140	275	410	685	1,145	2,060
1,350	20 (2)	105	205	310	515	860	1,545
1,400	20 (2)	75	150	225	380	630	1,130
1,450	20 (2)	60	115	175	290	485	875
1,500	15 (2)	40	85	125	205	345	620
<b>B — Special Class</b>							
Temperature, °F	Working Pressure by Class, psig						
	150	300	600	900	1500	2500	4500
-20 to 100	290	750	1,500	2,250	3,750	6,250	11,250
200	290	750	1,500	2,250	3,750	6,250	11,250
300	290	750	1,500	2,250	3,750	6,250	11,250
400	290	750	1,500	2,250	3,750	6,250	11,250
500	290	750	1,500	2,250	3,750	6,250	11,250
600	290	750	1,500	2,250	3,750	6,250	11,250
650	290	750	1,500	2,250	3,750	6,250	11,250
700	280	735	1,465	2,200	3,665	6,110	10,995
750	280	730	1,460	2,185	3,645	6,070	10,930
800	275	720	1,440	2,160	3,600	6,000	10,800
850	260	680	1,355	2,030	3,385	5,645	10,160
900	230	600	1,200	1,800	3,000	5,000	9,000
950	180	470	945	1,415	2,360	3,930	7,070
1,000	160	420	840	1,260	2,105	3,505	6,310

**Table VII-2-3.19 Ratings for Group 3.19 Materials (Cont'd)**

<b>B — Special Class</b>							
<b>Temperature, °F</b>	<b>Working Pressure by Class, psig</b>						
	<b>150</b>	<b>300</b>	<b>600</b>	<b>900</b>	<b>1500</b>	<b>2500</b>	<b>4500</b>
1,050	160	420	840	1,260	2,105	3,505	6,310
1,100	155	405	805	1,210	2,015	3,360	6,045
1,150	130	345	685	1,030	1,715	2,860	5,145
1,200	100	260	515	770	1,285	2,145	3,860
1,250	90	230	455	680	1,135	1,895	3,410
1,300	65	170	345	515	860	1,430	2,570
1,350	50	130	260	385	645	1,070	1,930
1,400	35	95	190	285	470	785	1,415
1,450	30	75	145	220	365	610	1,095
1,500	20	50	105	155	260	430	770

## NOTES:

(1) Use annealed material only.

(2) For welding-end valves only. Flanged-end valve ratings terminate at 1,000°F.

## MANDATORY APPENDIX VIII REFERENCES

(17)

The following is a list of standards and specifications referenced in this Standard. Products covered by each ASTM specification are listed for convenience. (See specifications for exact titles and detailed contents.) Materials manufactured to other editions of the referenced ASTM specifications may be used to manufacture valves meeting the requirements of this Standard as long as the valve manufacturer verifies that each material meets the requirements of the referenced edition.

- API Std 598-1996, Valve Inspection and Testing  
 Publisher: American Petroleum Institute (API), 1220 L Street NW, Washington, DC 20005-4070 ([www.api.org](http://www.api.org))
- ASME B1.1, Unified Inch Screw Threads (UN and UNR Thread Form)
- ASME B1.20.1, Pipe Threads, General Purpose (Inch)
- ASME B16.5, Pipe Flanges and Flanged Fittings
- ASME B16.10, Face-to-Face and End-to-End Dimensions of Valves
- ASME B16.11, Forged Fittings, Socket-Welding and Threaded
- ASME B16.20, Metallic Gaskets for Pipe Flanges: Ring-Joint, Spiral-Wound, and Jacketed
- ASME B16.21, Nonmetallic Flat Gaskets for Pipe Flanges
- ASME B16.25, Buttwelding Ends
- ASME B16.47, Large Diameter Steel Flanges
- ASME B18.2.1, Square Hex, Heavy Hex, and Askew Head Bolts and Hex, Heavy Hex, Hex Flange, Lobed Head, and Lag Screws (Inch Series)
- ASME B18.2.2, Nuts for General Applications: Machine Screw Nuts, Hex, Square, Hex Flange, and Coupling Nuts (Inch Series)
- ASME B31.3, Process Piping
- ASME B36.10M, Welded and Seamless Wrought Steel Pipe
- ASME PCC-1, Guidelines for Pressure Boundary Bolted Flange Joint Assembly
- ASME Boiler and Pressure Vessel Code, Section I, Rules for Construction of Power Boilers
- ASME Boiler and Pressure Vessel Code, Section III, Rules for Construction of Nuclear Power Plant Components, Division 1
- ASME Boiler and Pressure Vessel Code, Section VIII, Rules for Construction of Pressure Vessels — Division 1
- ASME Boiler and Pressure Vessel Code, Section VIII, Rules for Construction of Pressure Vessels — Division 2, Alternative Rules
- ASME Boiler and Pressure Vessel Code, Section IX, Qualification Standard for Welding, Brazing, and Fusing Procedures; Welders; Brazers; and Welding, Brazing, and Fusing Operators  
 Publisher: The American Society of Mechanical Engineers (ASME), Two Park Avenue, New York, NY 10016-5990 ([www.asme.org](http://www.asme.org))
- ASTM A105/A105M-2005, Carbon Steel Forgings for Piping Applications
- ASTM A106/A106M-2006a, Seamless Carbon Steel Pipe for High-Temperature Service
- ASTM A182/A182M-2007, Forged or Rolled Alloy-Steel Pipe Flanges, Forged Fittings, and Valves and Parts for High-Temperature Service
- ASTM A193/A193M-2007, Alloy-Steel and Stainless Steel Bolting Materials for High-Temperature or High-Pressure Service and Other Special Purpose Applications
- ASTM A194/A194M-2007a, Carbon and Alloy Steel Nuts for Bolts for High-Pressure and High-Temperature Service, or Both
- ASTM A203/A203M-1997, Pressure Vessel Plates, Alloy Steel, Nickel
- ASTM A204/A204M-2003, Pressure Vessel Plates, Alloy Steel, Molybdenum
- ASTM A207-74a, Carbon-Moly Steel Plates (discontinued 1972)
- ASTM A216/A216M-2007, Steel Castings, Carbon, Suitable for Fusion Welding, for High-Temperature Service
- ASTM A217/A217M-2007, Steel Castings, Martensitic Stainless and Alloy, for Pressure Containing Parts, Suitable for High-Temperature Service
- ASTM A240/A240M-2007, Chromium and Chromium-Nickel Stainless Steel Plate, Sheet, and Strip for Pressure Vessels and for General Applications
- ASTM A275/A275M-2008, Magnetic Particle Examination of Steel Forgings
- ASTM A302/A302M-2003 (R2007), Pressure Vessel Plates, Alloy Steel, Manganese-Molybdenum and Manganese-Molybdenum-Nickel
- ASTM A307-2004e1, Carbon Steel Bolts and Studs, 60,000 psi Tensile Strength
- ASTM A312/A312M-2008, Seamless, Welded, and Heavily Cold Worked Austenitic Stainless Steel Pipes

- ASTM A320/A320M-2007, Alloy/Steel Bolting Materials for Low-Temperature Service
- ASTM A335/A335M-2006, Seamless Ferritic Alloy-Steel Pipe for High-Temperature Service
- ASTM A350/A350M-2004a, Carbon and Low-Alloy Steel Forgings, Requiring Notch Toughness Testing for Piping Components
- ASTM A351/A351M-2014, Castings, Austenitic, for Pressure Containing Parts
- ASTM A352/A352M-2006, Steel Castings, Ferritic and Martensitic, for Pressure-Containing Parts, Suitable for Low-Temperature Service
- ASTM A354-2004e1, Quenched and Tempered Alloy Steel Bolts, Studs, and Other Externally Threaded Fasteners
- ASTM A358/A358M-2008, Electric-Fusion-Welded Austenitic Chromium-Nickel Stainless Steel Pipe for High-Temperature Service and General Applications
- ASTM A369/A369M-2006, Carbon and Ferritic Alloy Steel Forged and Bored Pipe for High-Temperature Service
- ASTM A376/A376M-2006, Seamless Austenitic Steel Pipe for High-Temperature Central-Station Service
- ASTM A387/A387M-2006a, Pressure Vessel Plates, Alloy Steel, Chromium-Molybdenum
- ASTM A388/A388M-2009, Ultrasonic Examination of Steel Forgings
- ASTM A430-91, Austenitic Steel Forged or Bored Pipe (replaced by ASTM A312-2001a)
- ASTM A453/A453M-2004, High-Temperature Bolting Materials, with Expansion Coefficients Comparable to Austenitic Stainless Steels
- ASTM A479/A479M-2008, Stainless Steel Bars and Shapes for Use in Boilers and Other Pressure Vessels
- ASTM A488/A488M-2007, Steel Castings, Welding, Qualifications of Procedures and Personnel
- ASTM A494/A494M-2009, Castings, Nickel and Nickel Alloy
- ASTM A515/A515M-2003, Pressure Vessel Plates, Carbon Steel, for Intermediate- and Higher-Temperature Service
- ASTM A516/A516M-2006, Pressure Vessel Plates, Carbon Steel, for Moderate- and Lower-Temperature Service
- ASTM A537/A537M-2006, Pressure Vessel Plates, Heat-Treated, Carbon-Manganese-Silicon Steel Plates
- ASTM A540/A540M-2006, Alloy-Steel Bolting Materials for Special Applications
- ASTM A609/A609M-1991 (R2007), Castings, Carbon, Low-Alloy, and Martensitic Stainless Steel, Ultrasonic Examination Thereof
- ASTM A672-2008, Electric-Fusion-Welded Steel Pipe for High Pressure Service at Moderate Temperatures
- ASTM A675/A675M-2003 (R2009), Steel Bars, Carbon, Hot-Wrought, Special Quality, Mechanical Properties
- ASTM A691-1998 (R2007), Carbon and Alloy Steel Pipe, Electric-Fusion Welded for High-Pressure Service at High Temperatures
- ASTM A696-1990a (R2006), Steel Bars, Carbon, Hot-Wrought or Cold-Finished, Special Quality, for Pressure Piping Components
- ASTM A739-1990a (R2006), Steel Bars, Alloy, Hot-Wrought, for Elevated Temperature or Pressure-Containing Parts, or Both
- ASTM A789/A789M-2008b, Seamless and Welded Ferritic/Austenitic Stainless Steel Tubing for General Service
- ASTM A790/A790M-2004, Seamless and Welded Ferritic/Austenitic Stainless Steel Pipe
- ASTM A995/A995M-2013, Castings, Austenitic-Ferritic (Duplex) Stainless Steel, for Pressure-Containing Parts
- ASTM B127-2005 (R2009), Nickel-Copper Alloy (UNS N04400) Plate, Sheet, and Strip
- ASTM B160-2005, Nickel Rod and Bar
- ASTM B161-2005, Nickel Seamless Pipe and Tube
- ASTM B162-1999 (R2005), Nickel Plate, Sheet, and Strip
- ASTM B163-2008, Seamless Nickel and Nickel Alloy Condenser and Heat-Exchanger Tubes
- ASTM B164-2003, Nickel-Copper Alloy Rod, Bar, and Wire
- ASTM B165-2005, Nickel-Copper Alloy (UNS N04400) Seamless Pipe and Tube
- ASTM B166-2006, Nickel-Chromium-Iron Alloys (UNS N06600, N06601, N06603, N06690, N06693, N06025, and N06045) and Nickel-Chromium-Cobalt-Molybdenum Alloy (UNS N06617) Rod, Bar, and Wire
- ASTM B167-2008, Nickel-Chromium-Iron Alloys (UNS N06600, N06601, N06603, N06690, N06693, N06025, and N06045) and Nickel-Chromium-Cobalt-Molybdenum Alloy (UNS N06617) Seamless Pipe and Tube
- ASTM B168-2006, Nickel-Chromium-Iron Alloys (UNS N06600, N06601, N06603, N06690, N06693, N06025, and N06045) and Nickel-Chromium-Cobalt-Molybdenum Alloy (UNS N06617) Plate, Sheet, and Strip
- ASTM B333-2003 (R2008), Nickel-Molybdenum Alloy Plate, Sheet, and Strip
- ASTM B335-2003 (R2013), Nickel-Molybdenum Alloy Rod
- ASTM B407-2008a, Nickel-Iron-Chromium Alloy Seamless Pipe and Tube
- ASTM B408-2006 (R2016), Nickel-Iron-Chromium Alloy Rod and Bar
- ASTM B409-2006 (R2016), Nickel-Iron-Chromium Alloy Plate, Sheet, and Strip
- ASTM B423-2005 (R2009), Nickel-Iron-Chromium-Molybdenum-Copper Alloy (UNS N08825 and N08221) Seamless Pipe and Tube
- ASTM B424-2005 (R2009), Ni-Fe-Cr-Mo-Cu Alloy (UNS N08825 and N08221) Plate, Sheet, and Strip
- ASTM B425-1999 (R2009), Ni-Fe-Cr-Mo-Cu Alloy (UNS N08825 and UNS N08221) Rod and Bar

- ASTM B434-2006, Nickel-Molybdenum-Chromium-Iron Alloys (UNS N10003, UNS N10242) Plate, Sheet, and Strip
- ASTM B435-2006 (R2016), UNS N06002, UNS N06230, UNS N12160, and UNS R30556 Plate, Sheet, and Strip
- ASTM B443-2000 (R2014), Nickel-Chromium-Molybdenum-Columbium Alloy (UNS N06625) and Nickel-Chromium-Molybdenum-Silicon Alloy (UNS N06219) Plate, Sheet, and Strip
- ASTM B446-2003 (R2014), Nickel-Chromium-Molybdenum-Columbium Alloy (UNS N06625), Nickel-Chromium-Molybdenum-Silicon Alloy (UNS N06219), and Nickel-Chromium-Molybdenum-Tungsten Alloy (UNS N06650) Rod and Bar
- ASTM B462-2006, Forged or Rolled UNS N06030, UNS N06022, UNS N06035, UNS N06200, UNS N06059, UNS N06686, UNS N08020, UNS N08024, UNS N08026, UNS N08367, UNS N10276, UNS N10665, UNS N10675, UNS N10629, UNS N08031, UNS N06045, UNS N06025, and UNS R20033 Alloy Pipe Flanges, Forged Fittings, and Valves and Parts for Corrosive High-Temperature Service
- ASTM B463-2004 (R2009), UNS N08020, UNS N08024, and UNS N08026 Alloy Plate, Sheet, and Strip
- ASTMB464-2005 (R2009), Welded UNS N08020, N08024, and N08026 Alloy Pipe
- ASTMB468-2004 (R2009), Welded UNS N08020, N08024, and N08026 Alloy Tubes
- ASTM B473-2007 (R2013), UNS N08020, UNS N08024, and UNS N08026 Nickel Alloy Bar and Wire
- ASTM B511-2001 (R2009), Nickel-Iron-Chromium-Silicon Alloy Bars and Shapes
- ASTM B535-2006 (R2017), Nickel-Iron-Chromium-Silicon Alloys (UNS N08330 and N08332) Seamless Pipe and Tube
- ASTM B536-2007 (R2013), Nickel-Iron-Chromium-Silicon Alloy (UNS N08330 and N08332) Plate, Sheet, and Strip
- ASTM B564-2006a, Nickel Alloy Forgings
- ASTM B572-2006 (R2016), UNS N06002, UNS N06230, UNS N12160, and UNS R30556 Rod
- ASTM B573-2006 (R2016), Nickel-Molybdenum-Chromium-Iron Alloy (UNS N10003, N10242) Rod
- ASTM B574-2006, Low-Carbon Nickel-Chromium-Molybdenum, Low-Carbon Nickel Molybdenum-Chromium-Tantalum, Low-Carbon Nickel Chromium-Molybdenum-Copper, Low-Carbon Nickel-Chromium-Molybdenum-Tungsten Alloy Rod
- ASTM B575-2006, Low-Carbon Nickel-Chromium-Molybdenum, Low-Carbon Nickel-Chromium-Molybdenum-Copper, Low-Carbon Nickel-Chromium-Molybdenum-Tantalum, and Low-Carbon Nickel-Chromium-Molybdenum-Tungsten Alloy Plate, Sheet, and Strip
- ASTM B581-2002 (R2008), Nickel-Chromium-Iron-Molybdenum-Copper Alloy Rod
- ASTM B582-2002, Nickel-Chromium-Iron-Molybdenum-Copper Alloy Plate, Sheet, and Strip
- ASTM B599-1992 (R2014), Nickel-Iron-Chromium-Molybdenum-Columbium Stabilized Alloy (UNS N08700) Plate, Sheet, and Strip
- ASTM B620-2003 (R2013), Nickel-Iron-Chromium-Molybdenum Alloy (UNS N08320) Plate, Sheet, and Strip
- ASTM B621-2002 (R2016), Nickel-Iron-Chromium-Molybdenum Alloy (UNS N08320) Rod
- ASTM B622-2006, Seamless Nickel and Nickel-Cobalt Alloy Pipe and Tube
- ASTM B625-2005 (R2011), UNS N08925, UNS N08031, UNS N08932, UNS N08926, UNS N08354, and UNS R20033 Plate, Sheet, and Strip
- ASTM B649-2006 (R2016), Ni-Fe Cr-Mo-Cu-N Low-Carbon Alloys (UNS N08925, UNS N08031, UNS N08354, and UNS N08926), and Cr-Ni-Fe-N Low-Carbon Alloy (UNS R20033) Bar and Wire, and Ni-Cr-Fe-Mo-N Alloy (UNS N08936) Wire
- ASTM B672-2002 (R2013), Nickel-Iron-Chromium-Molybdenum-Columbium Stabilized Alloy (UNS N08700) Bar and Wire
- ASTM B677-2004, UNS N08904, UNS N08925, and UNS N08926 Seamless Pipe and Tube
- ASTM B688-1996 (R2004), Chromium-Nickel-Molybdenum-Iron (UNS N08366 and UNS N08367) Plate, Sheet, and Strip
- ASTM B691-2002 (R2013), Iron-Nickel-Chromium-Molybdenum Alloys (UNS N08366 and UNS N08367) Rod, Bar, and Wire
- ASTM E29-2006b, Using Significant Digits in Test Data to Determine Conformance with Specifications
- ASTM E94-2004 (R2010), Standard Guide for Radiographic Examination
- ASTM E165-2002, Liquid Penetrant Inspection Method
- ASTM E186-1998 (R2004), Reference Radiographs for Heavy-Walled (2 to 4½ in. [51 to 114-mm]) Steel Castings
- ASTM E280-1998 (R2004), Reference Radiographs for Heavy-Walled (4½ to 12 in. [114 to 305-mm]) Steel Castings
- ASTM E446-1998 (R2004), Standard Reference Radiographs for Steel Castings up to 2 in. [51 mm] in Thickness
- ASTM E709-2008, Standard Guide for Magnetic Particle Testing
- Publisher: American Society for Testing and Materials (ASTM International), 100 Barr Harbor Drive, P.O. Box C700, West Conshohocken, PA 19428-2959 (www.astm.org)
- ISO 5208:2008, Industrial valves — Pressure testing of metallic valves<sup>1</sup>

<sup>1</sup> May also be obtained from American National Standards Institute (ANSI), 25 West 43rd Street, New York, NY 10036.

ISO 9000:2000, Quality management systems — Fundamentals and vocabulary <sup>1</sup>	MSS SP-25-1998, Standard Marking System for Valves, Fittings, Flanges, and Unions
ISO 9001:2000, Quality management systems — Requirements <sup>1</sup>	MSS SP-55-2006, Quality Standard for Steel Casting for Valves, Flanges, and Fittings
ISO 9004:2000, Quality management systems — Guideline for performance improvements <sup>1</sup>	MSS SP-61-2003, Pressure Testing of Steel Valves
Publisher: International Organization for Standardization (ISO), Central Secretariat, Chemin de Blandonnet 8, CP 401, 1214 Vernier, Geneva, Switzerland (www.iso.org)	MSS SP-134-2012, Valves for Cryogenic Service Including Requirements for Body/Bonnet Extensions Publisher: Manufacturers Standardization Society (MSS), 127 Park Street, NE, Vienna, VA 22180 (www.msshq.org)

## NONMANDATORY APPENDIX A

### RELATIONSHIP BETWEEN NOMINAL PIPE SIZE AND INSIDE DIAMETER

The relationship between wall thickness and inside diameter shown in [Table 3A](#) or [Table 3B](#) is the basis for pressure rating of valves. By interpolation, a definitive design can be determined for any pressure-diameter-material combination.

Following the evolution of standard dimensions for flanges in a series of rating classes, corresponding standard relationships were established between nominal pipe sizes and the inside diameter of fittings matching the rating class of the flanges. These provided a useful

design basis for the corresponding flanged-end valves, subsequently extended in application to welding-end valves, which in many cases are identical except for the pipe ends. [Table A-1](#) is based on the dimensions given in ASME B16.5 dimensional tables as “Inside Diameter of Fitting.” The values for sizes greater than NPS 24 for the lower pressure classes and greater than NPS 12 for Class 2500 were obtained by linear extrapolation.

(17)

**Table A-1 Inside Diameter, *d***

NPS	Class 150		Class 300		Class 600		Class 900		Class 1500		Class 2500		DN
	mm	in.	mm	in.	mm	in.	mm	in.	mm	in.	mm	in.	
1/2	12.7	0.50	12.7	0.50	12.7	0.50	12.7	0.50	12.7	0.50	11.2	0.44	15
3/4	19.1	0.75	19.1	0.75	19.1	0.75	17.5	0.69	17.5	0.69	14.2	0.56	20
1	25.4	1.00	25.4	1.00	25.4	1.00	22.1	0.87	22.1	0.87	19.1	0.75	25
1 1/4	31.8	1.25	31.8	1.25	31.8	1.25	28.4	1.12	28.4	1.12	25.4	1.00	32
1 1/2	38.1	1.50	38.1	1.50	38.1	1.50	34.8	1.37	34.8	1.37	28.4	1.12	40
2	50.8	2.00	50.8	2.00	50.8	2.00	47.5	1.87	47.5	1.87	38.1	1.50	50
2 1/2	63.5	2.50	63.5	2.50	63.5	2.50	57.2	2.25	57.2	2.25	47.5	1.87	65
3	76.2	3.00	76.2	3.00	76.2	3.00	72.9	2.87	69.9	2.75	57.2	2.25	80
4	101.6	4.00	101.6	4.00	101.6	4.00	98.3	3.87	91.9	3.62	72.9	2.87	100
5	127.0	5.00	127.0	5.00	127.0	5.00	120.7	4.75	111.0	4.37	91.9	3.62	125
6	152.4	6.00	152.4	6.00	152.4	6.00	146.1	5.75	136.4	5.37	111.0	4.37	150
8	203.2	8.00	203.2	8.00	199.9	7.87	190.5	7.50	177.8	7.00	146.1	5.75	200
10	254.0	10.00	254.0	10.00	247.7	9.75	238.0	9.37	222.3	8.75	184.2	7.25	250
12	304.8	12.00	304.8	12.00	298.5	11.75	282.4	11.12	263.4	10.37	218.9	8.62	300
14	336.6	13.25	336.6	13.25	326.9	12.87	311.2	12.25	288.8	11.37	241.3	9.50	350
16	387.4	15.25	387.4	15.25	374.7	14.75	355.6	14.00	330.2	13.00	276.1	10.87	400
18	438.2	17.25	431.8	17.00	419.1	16.50	400.1	15.75	371.3	14.62	311.2	12.25	450
20	489.0	19.25	482.6	19.00	463.6	18.25	444.5	17.50	415.8	16.37	342.9	13.50	500
22	539.8	21.25	533.4	21.00	511.0	20.12	489.0	19.25	457.2	18.00	377.7	14.87	550
24	590.6	23.25	584.2	23.00	558.8	22.00	533.4	21.00	498.3	19.62	412.8	16.25	600
26	641.4	25.25	635.0	25.00	603.3	23.75	577.9	22.75	539.8	21.25	447.5	17.62	650
28	692.2	27.25	685.8	27.00	647.7	25.50	622.3	24.50	584.2	23.00	482.6	19.00	700
30	743.0	29.25	736.6	29.00	695.2	27.37	666.8	26.25	625.3	24.62	517.4	20.37	750
32	793.7	31.25	787.4	31.00	736.6	29.00	711.2	28.00	...	...	...	...	...
34	844.5	33.25	838.2	33.00	781.0	30.75	755.6	29.75	...	...	...	...	...
36	895.3	35.25	889.0	35.00	828.5	32.62	800.1	31.50	...	...	...	...	...
38	946.1	37.25	939.8	37.00	872.9	34.37	844.5	33.25	...	...	...	...	...
40	996.9	39.25	990.6	39.00	920.7	36.25	889.0	35.00	...	...	...	...	...
42	1 047.7	41.25	1 041.4	41.00	965.2	38.00	933.4	36.75	...	...	...	...	...
44	1 098.5	43.25	1 092.2	43.00	1 012.6	39.87	977.9	38.50	...	...	...	...	...
46	1 149.3	45.25	1 143.0	45.00	1 057.1	41.62	1 022.3	40.25	...	...	...	...	...
48	1 200.1	47.25	1 193.8	47.00	1 104.9	43.50	1 066.8	42.00	...	...	...	...	...
50	1 250.9	49.25	1 244.6	49.00	1 149.3	45.25	1 111.2	43.75	...	...	...	...	...
52	1 301.7	51.25	1 295.4	51.00	1 193.8	47.00	...	...	...	...	...	...	...
54	1 352.5	53.25	1 346.2	53.00	1 241.2	48.87	...	...	...	...	...	...	...
56	1 403.3	55.25	1 397.0	55.00	1 285.7	50.62	...	...	...	...	...	...	...
58	1 454.1	57.25	1 447.8	57.00	1 330.1	52.37	...	...	...	...	...	...	...
60	1 504.9	59.25	1 498.6	59.00	1 374.6	54.12	...	...	...	...	...	...	...



# NONMANDATORY APPENDIX B

## METHOD USED FOR ESTABLISHING PRESSURE-TEMPERATURE RATINGS

### B-1 GENERAL CONSIDERATIONS

#### B-1.1 Introduction

Pressure-temperature ratings for this Standard have been determined by the procedures described in this Appendix. The method is general and considers dimensions of this and related standards.<sup>1</sup> Valve performance is related to stress and deformation. Valves require special consideration since they are mechanically operated devices that must be able to provide partial or complete restriction to fluid flow under a wide variety of conditions.

#### B-1.2 Materials

It is not required that identical materials be used for a valve body and bonnet or a valve body and cover. However, both shall be from materials listed in [Table 1](#). The assigned pressure rating shall be based on the valve body. The bonnet or cover shall be designed and the material selected accordingly. Selection of material for and the design of stems, discs, and other parts, such as bonnet gaskets and bolting, subject to pressure loading, shall be consistent with the pressure-temperature rating.

#### B-1.3 Wall Thickness

Wall thickness requirements for valve bodies are specified in [para. 6.1](#). The minimum wall thickness values,  $t_m$ , shown in [Table 3A](#) or [Table 3B](#) calculated using the applicable equation of [Mandatory Appendix VI](#) are all greater than those determined by the following equation. [Equation \(B-1\)](#) is included only as an item of general interest. [Equation \(B-1\)](#) is not to be used for design calculations and is not to be used as a substitute for either [Table 3A](#) or [Table 3B](#) values or [Mandatory Appendix VI](#) equations.

$$t = 1.5 \left[ \frac{P_c d}{2S_F - 1.2P_c} \right] \quad (\text{B-1})$$

where

<sup>1</sup>This method is appropriate for materials listed in [Table 1](#) of this Standard. It may not be appropriate for other materials.

$d$  = inside diameter or port opening as defined in [para. 6.1.2](#), (see [Table 3A](#) or [Table 3B](#) and [Nonmandatory Appendix A](#))

$P_c$  = pressure class designation number, e.g., for Class 150,  $P_c = 150$ ; or Class 300,  $P_c = 300$

$S_F$  = stress-based constant equal to 7,000

$t$  = calculated thickness

The equation does not apply for values of  $P_c$  greater than 4,500. The resultant units for  $t$  will be the same as those used to express  $d$ .

#### B-1.4 Additional Considerations

The [equation \(B-1\)](#) results in a wall thickness of 50% greater for Class 150 to 2500 and approximately 35% greater for Class 4500 than for a simple cylinder designed for a stress of 48.28 MPa (7000 psi) subjected to an internal pressure equal to the pressure rating class designation,  $P_c$ . The actual values in [Table 3A](#) or [Table 3B](#) are approximately 2.5 mm (0.1 in.) larger than those given by the equation. Additional metal thickness, particularly for ratings over Class 2500, needed for assembly stress, valve closing stresses, shapes other than circular, and stress concentrations must be determined by individual manufacturers, since these factors vary widely.

#### B-1.5 Material Properties

The pressure-temperature rating method uses allowable stresses, ultimate strengths, and yield strengths from referenced ASME Boiler and Pressure Vessel Code Sections, including their published Code Cases. For materials listed herein that have ratings either at temperature values that are above those shown in a referenced Code section or that are not listed in any of the referenced Code sections, the allowable stress, ultimate strength, and yield strength data have been provided directly by the ASME Boiler and Pressure Vessel Subcommittee on Materials.

#### B-1.6 Material Groups

Materials are grouped in [Table 1](#) based on identical or closely matched allowable stress, ultimate tensile stress, and yield strength values. When these values are not

identical for each material listed, the lowest value has been used.

## B-2 STANDARD CLASS RATING METHOD

### B-2.1 Method for Group 1 Materials

Pressure–temperature ratings for Standard Class valves, Class 300 and higher, of materials listed in Materials Group 1 of [Table 1](#), were established by the equation

$$p_{st} = \frac{C_1 S_1}{8750} P_r \leq p_{ca} \quad (\text{B-2})$$

where

$C_1$  = 10 when  $S_1$  is expressed in MPa units, the resultant  $p_{st}$  will be in bar units ( $C_1 = 1$  when  $S_1$  is expressed in psi units, the resultant  $p_{st}$  will be in psi units)

$P_r$  = pressure class rating index. For designations 300 ≤ Class ≤ 4500 and above,  $P_r$  is equal to the class designation number, e.g., for Class 300,  $P_r = 300$ . For Class 150 and for the interpolation method required for rating designations between Class 150 and 300, see [para. B-2.3](#).

$p_{ca}$  = ceiling pressure, bar (psi), at temperature  $T$  as specified in [para. B-5](#) for Standard Class

$p_{st}$  = Standard Class rated working pressure, bar, (psi) for the specified material at temperature  $T$

$S_1$  = selected stress, MPa (psi) for the specified material at temperature  $T$ . The value of  $S_1$  shall be established as follows:

(a) At temperatures below the creep range,  $S_1$  shall be equal to or less than 60% of the yield strength at temperature  $T$ , but shall not exceed

(1) 60% of the specified minimum yield strength at 38°C (100°F)

(2) 1.25 times 25% of the ultimate tensile strength at temperature  $T$

(b) At temperatures in the creep range, the value of  $S_1$  shall be the allowable stress at temperature  $T$ , as listed in ASME Boiler and Pressure Vessel Code, Section II, Part D, for either Section I or Section VIII, Division 1; but not exceeding 60% of the listed yield strength at temperature.

(c) In no case shall the selected stress value increase with increasing temperature.

(d) The creep range is considered to be at temperatures in excess of 370°C (700°F) for Group 1 materials.

(e) When the allowable stresses listed for the referenced ASME Boiler and Pressure Vessel Code Section show a higher and lower value for allowable stress and the higher value is noted to the effect that these stress values exceed two-thirds of the yield strength at

temperature, then the lower value shall be used. If lower allowable stress values do not appear and it is noted in the allowable stress table that the allowable stress values exceed two-thirds of the yield strength at temperature, then the allowable stress values to be used shall be determined as two-thirds of the tabulated yield strength at temperature.

(f) Ultimate tensile strength and yield strength values shall be as listed in ASME Boiler and Pressure Vessel Code, Section II, Part D.

(g) Allowable stress values listed in ASME Boiler and Pressure Vessel Code, Section II, Part D, for Section III, Class 2 or Class 3 values may only be used for a material not listed for either Section I or Section VIII, Division 1.

### B-2.2 Method for Groups 2 and 3 Materials

Pressure–temperature ratings for Standard Class valves, 300 ≤ Class ≤ 4500, of materials corresponding to those in Materials Groups 2 and 3 of [Table 1](#) are established by the method of [para. B-2.1](#), except that in [paras. B-2.1\(a\)](#) and [B-2.1\(a\)\(1\)](#), 60% factor shall be changed to 70%, and, for Group 2 materials, the creep range is considered to be at temperatures in excess of 510°C (950°F) unless the material properties indicate lower temperatures should be used. For Group 3 materials, the creep temperature onset for [B-2.1\(d\)](#) shall be determined on an individual basis.

### B-2.3 Method for Class 150 — All Materials

Pressure–temperature ratings for Standard Class valves, Class 150 rating designation, are established by the method given for the related materials in [paras. B-2.1](#) and [B-2.2](#), subject to the following exceptions:

(a) The value of  $P_r$ , the pressure class rating index in [eq. \(B-2\)](#), for Class 150 shall be 115. For a rating designation between Class 150 and Class 300, an interpolation shall be made using  $P_r = 115$  psi for Class 150.

(b) The value for  $S_1$ , the selected stress MPa (psi), for the specific material at temperature  $T$ , shall be in accordance with the requirements stated in either [para. B-2.1](#) or [B-2.2](#).

(c) The value of  $p_{st}$ , the rated working pressure, bar (psi), for Class 150, shall not exceed values at temperature,  $T$ , as given by [eq. \(B-3\)](#)

$$p_{st} \leq C_2 - C_3 T \quad (\text{B-3})$$

where

$C_2 = 21.41$  and  $C_3 = 0.03724$  with  $T$  expressed in °C, the resultant  $p_{st}$  will be in bar units ( $C_2 = 320$  and  $C_3 = 0.3$  with  $T$  expressed in °F, the resultant  $p_{st}$  will be in psi units)

$T$  = material temperature, °C (°F)

The value of  $T$  in eq. (B-3) shall not exceed 540°C (1,000°F). For values of  $T$  less than 38°C (100°F), use  $T$  equal to 38°C (100°F) in eq. (B-3).

### B-3 SPECIAL CLASS RATING METHOD

Pressure-temperature ratings for Special Class valves (see para. 2.1.2) are established for all materials of Table 1 by the equation

$$p_{sp} = \frac{C_2 S_2}{7000} P_r \leq p_{cb} \quad (\text{B-4})$$

where

$C_2$  = 10 when  $S_2$  is expressed in MPa units, the resultant  $p_{sp}$  will be in bar units ( $C_2 = 1$  when  $S_2$  is expressed in psi units, the resultant  $p_{sp}$  will be in psi units)

$P_r$  = pressure class rating index. For all designations Class 300 and above,  $P_r$  is equal to the class designation number, e.g. for Class 300,  $P_r = 300$ . For Class 150,  $P_r = 115$ . For a pressure class designation between Class 150 and Class 300, the interpolation for the rated working pressures shall be made using  $P_r = 115$  for Class 150.

$p_{cb}$  = ceiling pressure, bar (psi), at temperature  $T$  as specified in para. B-5 for Special Class

$p_{sp}$  = Special Class rated working pressure, bar (psi), for the specified material at temperature  $T$

$S_2$  = selected stress for the specified material at temperature  $T$ , MPa (psi). The value of  $S_2$  shall be established as follows:

(a) At temperatures below the creep range,  $S_2$  shall be equal to or less than 62.5% of the yield strength at temperature  $T$ , but shall not exceed

(1) 62.5% of the specified minimum yield strength at 38°C (100°F)

(2) 25% of the ultimate tensile stress value at temperature  $T$ .

(b) At temperatures in the creep range, the value of  $S_2$  shall be the allowable stress at temperature  $T$ , as listed in ASME Boiler and Pressure Vessel Code, Section II, Part D, for either Section I or Section VIII, Division 1; but not exceeding 62.5% of the yield strength at temperature  $T$ .

(c) In no case shall the selected stress value increase with increasing temperature.

(d) The creep range is to be considered that at temperatures in excess of 370°C (700°F) for Group 1 materials and 510°C (950°F) for Group 2 materials, unless material properties indicate lower temperatures to be used. For Group 3 materials, the creep range temperature limits shall be determined on an individual basis.

(e) When the allowable stresses listed for the referenced ASME Boiler and Pressure Vessel Code Section show a higher and a lower value for allowable stress and the higher value is noted to the effect that these stress values exceed two-thirds of the yield strength at temperature, then the lower value shall be used. If lower allowable stress values do not appear and it is noted in the ASME Boiler and Pressure Vessel Code, Section II, Part D allowable stress table that the allowable stress values exceed two-thirds of the yield strength at temperature, then the allowable stress values shall be determined as the lesser of two-thirds of the tabulated yield strength or the listed allowable stress at temperature.

(f) Ultimate tensile and yield strength values shall be as listed in ASME Boiler and Pressure Vessel Code, Section II, Part D.

(g) Allowable stress values listed in ASME Boiler and Pressure Vessel Code, Section II, Part D, for Section III, Class 2 or Class 3 values only, may be used for a material not listed for either Section I or Section VIII, Division 1.

### B-4 INTERMEDIATE RATING CLASS METHOD

#### B-4.1 Conception

Welding-end or threaded-end valves may be designed for an Intermediate Pressure Class designation. In this case it is necessary to perform multiple linear interpolation using the data in Table 2-1.1 through Table 2-3.19 and Table 3A and Table 3B in order to determine the intermediate pressure class designation, the intermediate pressure-temperature ratings, and the associated minimum wall thickness. Given at the start is the material identification, the intermediate working pressure, and its associated temperature.

#### B-4.2 Nomenclature

Definitions for paras. B-4.3 and B-4.4 are as follows:

$d_I$  = a given inside diameter, reference para. 6.1.2

$P_c$  = pressure class designation, reference B-1.3

$P_{cl}$  = the calculated intermediate pressure class designation for  $p_I$  at  $T_I$

$P_r$  = pressure class rating index, reference para. B-2.1

$P_{rI}$  = the calculated intermediate pressure class rating index for  $p_I$  at  $T_I$

$p_I$  = a given intermediate working pressure at  $T_I$

$T_I$  = a given temperature associated with  $p_I$

$t_I$  = the calculated required minimum wall thickness for  $P_{cl}$

**Table B-1 Pressure–Temperature Matrix**

$T$		$P_{rL}$	$P_{rI}$	$P_{rH}$	
$T_a$		$p_{aL}$	$p_{aI}$	$p_{aH}$	
$T_I$		$p_{IL}$	$p_I$	$p_{IH}$	
$T_b$		$p_{bL}$	$p_{bI}$	$p_{bH}$	

**B-4.3 Interpolation for Intermediate Pressure Ratings**

Given  $p_I$  at  $T_I$  and the valve material, refer to the applicable table for the pressure–temperature rating tabulation. For the given  $T_I$ , locate  $T_a$  and  $T_b$ , the temperatures above and below  $T_I$ . For the given  $p_I$ , locate  $p_{aL}$  and  $p_{aH}$  and also  $p_{bL}$  and  $p_{bH}$ , the bounding pressures lower and higher than  $p_I$ . These are identified with pressure class rating indices  $P_{rL}$  and  $P_{rH}$ . These are shown schematically in Table B-1.

(a) Interpolate to find intermediate pressures,  $p_{IL}$  and  $p_{IH}$  at intermediate temperature,  $T_I$ .

$$p_{IL} = p_{aL} - (p_{aL} - p_{bL}) \left( \frac{T_a - T_I}{T_a - T_b} \right) \tag{B-5}$$

$$p_{IH} = p_{aH} - (p_{aH} - p_{bH}) \left( \frac{T_a - T_I}{T_a - T_b} \right) \tag{B-6}$$

(b) Interpolate to find the intermediate pressure class rating index,  $P_{rI}$ .

$$P_{rI} = P_{rL} + (P_{rH} - P_{rL}) \left( \frac{p_I - p_{IL}}{p_{IH} - p_{IL}} \right) \tag{B-7}$$

(c) Interpolate to find the intermediate pressure class designation,  $P_{cI}$ .

$$P_{cI} = P_{cL} + (P_{cH} - P_{cL}) \left( \frac{P_{rI} - P_{rL}}{P_{rH} - P_{rL}} \right) \tag{B-8}$$

Note that for  $P_{cI} \geq 300$ ,  $P_{cI} = P_{rI}$ .

(d) Interpolate to find intermediate working pressures at temperature over the associated service temperature range applicable for  $P_{rI}$ . This interpolation is specifically required for the pressure rating at 38°C (100°F) that is needed for setting the hydrostatic test pressure and to

meet the marking requirements and for setting the pressure associated with any maximum limiting temperature. For example, for  $T = T_a$ , the interpolated working pressure rating is

$$P_{aI} = P_{aL} + (P_{aH} - P_{aL}) \left( \frac{P_{rI} - P_{rL}}{P_{rH} - P_{rL}} \right) \tag{B-9}$$

**B-4.4 Wall Thickness for Intermediate Ratings**

Given the valve inside diameter,  $d$  (para. 6.1.2), and the calculated intermediate pressure class designation,  $P_{cI}$ , [para. B-4.3(c)] refer to Table 3A or Table 3B for the minimum wall thickness tabulation. For the given inside diameter,  $d_I$ , locate  $d_a$  and  $d_b$ , the diameters above and below  $d_I$ . For the given  $P_{cI}$ , locate  $P_{cL}$  and  $P_{cH}$ , the pressure class designation lower and higher than  $P_{cI}$ . The bounding minimum wall thickness is at the row-column intersection as shown schematically in Table B-2.

(a) Interpolate to find intermediate minimum wall thicknesses,  $t_{IL}$  and  $t_{IH}$ , at intermediate diameter,  $d_I$ .

$$t_{IL} = t_{aL} + (t_{bL} - t_{aL}) \left( \frac{d_I - d_a}{d_b - d_a} \right) \tag{B-10}$$

$$t_{IH} = t_{aH} + (t_{bH} - t_{aH}) \left( \frac{d_I - d_a}{d_b - d_a} \right) \tag{B-11}$$

(b) Interpolate to find the intermediate minimum wall thickness,  $t_I$ .

$$t_I = t_{IL} + (t_{IH} - t_{IL}) \left( \frac{P_{cI} - P_{cL}}{P_{cH} - P_{cL}} \right) \tag{B-12}$$

**B-5 MAXIMUM RATINGS**

The rules for establishing Standard Class and Special Class pressure–temperature ratings include consideration of ceiling pressures,  $P_{ca}$  or  $P_{cb}$ , that effectively sets limits on the selected stress. The ceiling pressure–temperature values set an upper bound for high strength materials and are imposed to limit deflection. By definition, ceiling pressure values also apply to intermediate ratings (para. 2.1.5). Ceiling pressure values are listed in Tables B-3M and B-3. Except for Limited Class, ratings in excess of these are not permitted under this Standard.

**Table B-2 Class-Diameter Matrix**

$d$		$P_{cL}$	$P_{cI}$	$P_{cH}$	
$d_a$		$t_{aL}$	—	$t_{aH}$	
$d_I$		$t_{IL}$	$t_I$	$t_{IH}$	
$d_b$		$t_{bL}$	—	$t_{bH}$	

**Table B-3M Ceiling Pressure, bar**

<b>A — Standard Class</b>							
<b>Temperature, °C</b>	<b>Ceiling Pressures by Class, bar</b>						
	<b>150</b>	<b>300</b>	<b>600</b>	<b>900</b>	<b>1500</b>	<b>2500</b>	<b>4500</b>
-29 to 38	20.0	51.7	103.4	155.1	258.6	430.9	775.7
50	19.5	51.7	103.4	155.1	258.6	430.9	775.7
100	17.7	51.5	103.0	154.6	257.6	429.4	773.0
150	15.8	50.3	100.3	150.6	250.8	418.2	752.8
200	13.8	48.6	97.2	145.8	243.4	405.4	729.8
250	12.1	46.3	92.7	139.0	231.8	386.2	694.8
300	10.2	42.9	85.7	128.6	214.4	357.1	642.6
325	9.3	41.4	82.6	124.0	206.6	344.3	619.6
350	8.4	40.3	80.4	120.7	201.1	335.3	603.3
375	7.4	38.9	77.6	116.5	194.1	323.2	581.8
400	6.5	36.5	73.3	109.8	183.1	304.9	548.5
425	5.5	35.2	70.0	105.1	175.1	291.6	524.7
450	4.6	33.7	67.7	101.4	169.0	281.8	507.0
475	3.7	31.7	63.4	95.1	158.2	263.9	474.8
500	2.8	28.2	56.5	84.7	140.9	235.0	423.0
525	1.9	25.8	51.6	77.4	129.0	214.9	386.7
538	1.4	25.2	50.0	75.2	125.5	208.9	375.8
550	1.4	25.0	49.8	74.8	124.9	208.0	374.2
575	1.4	24.0	47.9	71.8	119.7	199.5	359.1
600	1.4	21.6	42.9	64.2	107.0	178.5	321.4
625	1.4	18.3	36.6	54.9	91.2	152.0	273.8
650	1.4	14.1	28.1	42.5	70.7	117.7	211.7
675	1.4	12.4	25.2	37.6	62.7	104.5	187.9
700	1.4	10.1	20.0	29.8	49.7	83.0	149.4
725	1.4	7.9	15.4	23.2	38.6	64.4	115.8
750	1.4	5.9	11.7	17.6	29.6	49.1	88.2
775	1.4	4.6	9.0	13.7	22.8	38.0	68.4
800	1.2	3.5	7.0	10.5	17.4	29.2	52.6
816	1.0	2.8	5.9	8.6	14.1	23.8	42.7
<b>B — Special Class</b>							
<b>Temperature, °C</b>	<b>Ceiling Pressures by Class, bar</b>						
	<b>150</b>	<b>300</b>	<b>600</b>	<b>900</b>	<b>1500</b>	<b>2500</b>	<b>4500</b>
-29 to 38	20.0	51.7	103.4	155.1	258.6	430.9	775.7
50	20.0	51.7	103.4	155.1	258.6	430.9	775.7
100	20.0	51.7	103.4	155.1	258.6	430.9	775.7
150	20.0	51.7	103.4	155.1	258.6	430.9	775.7
200	20.0	51.7	103.4	155.1	258.6	430.9	775.7
250	20.0	51.7	103.4	155.1	258.6	430.9	775.7
300	20.0	51.7	103.4	155.1	258.6	430.9	775.7
325	20.0	51.7	103.4	155.1	258.6	430.9	775.7
350	19.8	51.5	102.8	154.3	257.1	428.6	771.4
375	19.3	50.6	101.0	151.5	252.5	420.9	757.4
400	19.3	50.3	100.6	150.6	251.2	418.3	753.2

**Table B-3M Ceiling Pressure, bar (Cont'd)**

<b>B — Special Class</b>							
<b>Temperature, °C</b>	<b>Ceiling Pressures by Class, bar</b>						
	<b>150</b>	<b>300</b>	<b>600</b>	<b>900</b>	<b>1500</b>	<b>2500</b>	<b>4500</b>
425	19.0	49.6	99.3	148.9	248.2	413.7	744.6
450	18.1	47.3	94.4	141.4	235.8	393.1	707.6
475	16.4	42.8	85.5	128.2	213.7	356.3	641.3
500	13.7	35.6	71.5	107.1	178.6	297.5	535.4
525	11.7	30.5	61.2	91.8	153.2	255.1	459.2
538	11.0	29.0	57.9	86.9	145.1	241.7	435.1
550	11.0	29.0	57.9	86.9	145.1	241.7	435.1
575	10.9	28.6	57.1	85.7	143.0	238.3	428.8
600	10.3	26.9	53.5	80.4	134.0	223.4	401.9
625	8.7	23.0	45.7	68.6	114.3	190.6	342.8
650	6.9	17.9	35.5	53.1	88.6	147.9	266.1
675	6.2	16.0	31.6	47.3	78.9	131.7	237.0
700	4.8	12.4	25.0	37.3	62.3	103.7	186.5
725	3.7	9.7	19.5	28.9	48.3	80.2	144.5
750	2.8	7.4	14.8	22.1	36.7	61.2	110.3
775	2.2	5.8	11.4	17.2	28.5	47.6	85.6
800	1.8	4.4	8.8	13.2	22.0	36.6	65.6
816	1.4	3.4	7.2	10.7	17.9	29.6	53.1

**Table B-3 Ceiling Pressure, psi**

<b>A — Standard Class</b>							
<b>Temperature, °F</b>	<b>Ceiling Pressures by Class, psig</b>						
	<b>150</b>	<b>300</b>	<b>600</b>	<b>900</b>	<b>1500</b>	<b>2500</b>	<b>4500</b>
-20 to 100	290	750	1,500	2,250	3,750	6,250	11,250
200	260	750	1,500	2,250	3,750	6,250	11,250
300	230	730	1,455	2,185	3,640	6,070	10,925
400	200	705	1,410	2,115	3,530	5,880	10,585
500	170	665	1,330	1,995	3,325	5,540	9,965
600	140	605	1,210	1,815	3,025	5,040	9,070
650	125	590	1,175	1,765	2,940	4,905	8,825
700	110	570	1,135	1,705	2,840	4,730	8,515
750	95	530	1,065	1,595	2,660	4,430	7,970
800	80	510	1,015	1,525	2,540	4,230	7,610
850	65	485	975	1,460	2,435	4,060	7,305
900	50	450	900	1,350	2,245	3,745	6,740
950	35	385	775	1,160	1,930	3,220	5,795
1,000	20	365	725	1,090	1,820	3,030	5,450
1,050	20	360	720	1,080	1,800	3,000	5,400
1,100	20	325	645	965	1,610	2,685	4,835
1,150	20	275	550	825	1,370	2,285	4,115
1,200	20	205	410	620	1,030	1,715	3,085
1,250	20	180	365	545	910	1,515	2,725
1,300	20	140	275	410	685	1,145	2,060
1,350	20	105	205	310	515	860	1,545
1,400	20	75	150	225	380	630	1,130
1,450	20	60	115	175	290	485	875
1,500	15	40	85	125	205	345	620
<b>B — Special Class</b>							
<b>Temperature, °F</b>	<b>Ceiling Pressures by Class, psig</b>						
	<b>150</b>	<b>300</b>	<b>600</b>	<b>900</b>	<b>1500</b>	<b>2500</b>	<b>4500</b>
-20 to 100	290	750	1,500	2,250	3,750	6,250	11,250
200	290	750	1,500	2,250	3,750	6,250	11,250
300	290	750	1,500	2,250	3,750	6,250	11,250
400	290	750	1,500	2,250	3,750	6,250	11,250
500	290	750	1,500	2,250	3,750	6,250	11,250
600	290	750	1,500	2,250	3,750	6,250	11,250
650	290	750	1,500	2,250	3,750	6,250	11,250
700	280	735	1,465	2,200	3,665	6,110	10,995
750	280	730	1,460	2,185	3,645	6,070	10,930
800	275	720	1,440	2,160	3,600	6,000	10,800
850	260	680	1,355	2,030	3,385	5,645	10,160
900	230	600	1,200	1,800	3,000	5,000	9,000
950	180	470	945	1,415	2,360	3,930	7,070
1,000	160	420	840	1,260	2,105	3,505	6,310
1,050	160	420	840	1,260	2,105	3,505	6,310
1,100	155	405	805	1,210	2,015	3,360	6,045

**Table B-3 Ceiling Pressure, psi (Cont'd)**

<b>B — Special Class</b>							
<b>Temperature, °F</b>	<b>Ceiling Pressures by Class, psig</b>						
	<b>150</b>	<b>300</b>	<b>600</b>	<b>900</b>	<b>1500</b>	<b>2500</b>	<b>4500</b>
1,150	130	345	685	1,030	1,715	2,860	5,145
1,200	100	260	515	770	1,285	2,145	3,860
1,250	90	230	455	680	1,135	1,895	3,410
1,300	65	170	345	515	860	1,430	2,570
1,350	50	130	260	385	645	1,070	1,930
1,400	35	95	190	285	470	785	1,415
1,450	30	75	145	220	365	610	1,095
1,500	20	50	105	155	260	430	770



## NONMANDATORY APPENDIX C QUALITY SYSTEM PROGRAM

The products manufactured in accordance with this Standard shall be produced under a quality system program following the principles of an appropriate standard from the ISO 9000 series.<sup>1</sup> A determination of the need for registration and/or certification of the product manufacturer's quality system program by an independent organization shall be the responsibility of the manufacturer. Detailed documentation demonstrating

program compliance shall be available to the purchaser at the manufacturer's facility. A written summary description of the program used by the product manufacturer shall be available to the purchaser upon request. The product manufacturer is defined as the entity whose name or trademark appears on the product in accordance with the marking or identification requirements of this Standard.

---

<sup>1</sup>The series is also available from the American National Standards Institute (ANSI) and the American Society for Quality (ASQ) as American National Standards that are identified by the prefix "Q," replacing the prefix "ISO." Each standard of the series is listed under References in [Mandatory Appendix VIII](#).

# ASME B16.34-2017

ISBN 978-0-7918-7142-3



9 780791 871423



J 0 1 8 1 7